

**Customer**

## Technical data

### Glanded monobloc pump Atmos BST 65/125-7.5/2-V2

Project ID                      Untitled project 2025-03-01 17:12:44.130

Project name  
Installation location  
Customer pos. No.

Date                      2025-03-01

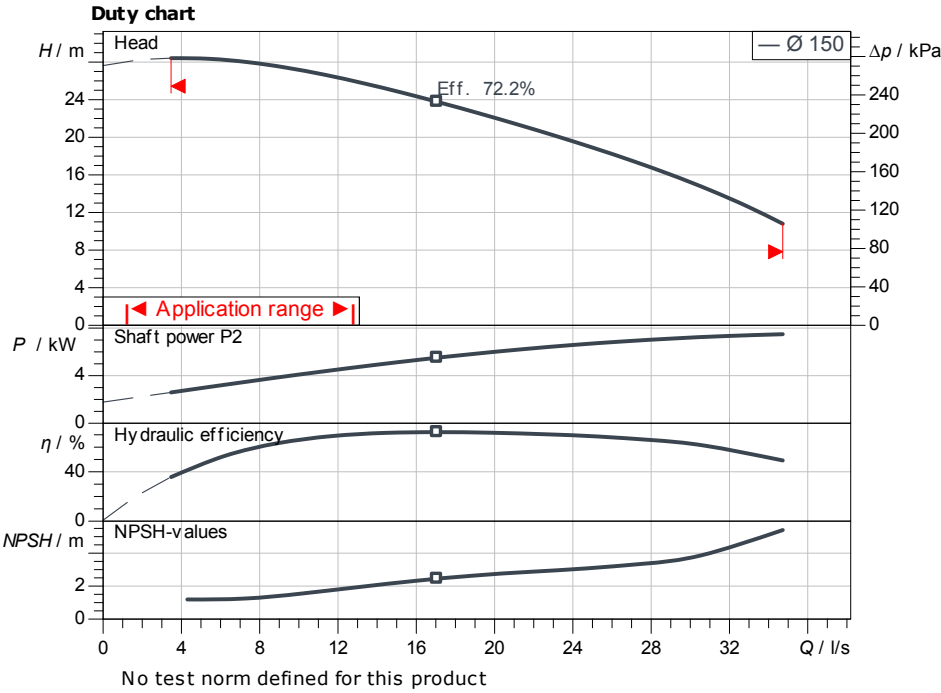

**Requested data**

Flow  
Head  
Media                      Water 100 %  
Fluid temperature                      20.00 °C  
Density                      998.30 kg/m<sup>3</sup>  
Kin. viscosity                      1.00 mm<sup>2</sup>/s

**Hydraulic data (Duty point)**

Flow  
Head  
Shaft power  $P_2$   
Hydraulic efficiency  
NPSH  
Impeller size                      150

**Product data**

Glanded monobloc pump  
Atmos BST 65/125-7.5/2-V2  
Max. operating pressure                      1,000 kPa  
Fluid temperature                      -20 °C ... +120 °C  
Max. ambient temperature                      50 °C  
Minimum efficiency index (MEI)                       $\geq 0.4$

**Motordata per Motor/Pump**

Motor efficiency level                      IE3  
Mains connection                      3~ 400 V / 50 Hz  
Permitted voltage tolerance                      +6 %  
Max. speed                      2,900 1/min  
Rated power  $P_2$                       7.50 kW  
Rated current                      13.70 A  
Power factor                      0.88  
Efficiency  
50% / 75% / 100%                      // %  
Degree of protection                      IP55  
Insulation class                      F  
Motor protection

**Fitting dimensions**

Pipe connection on the suction side                      DN 80, PN 16  
Pipe connection (pressure side)                      DN 65, PN 16  
Port to Port

**Materials**

Pump housing                      1.4301  
Impeller                      1.4301  
Shaft                      1.4301  
Shaft seal                      B3Q1EF

**Information for order placements**

Weight approx.  
Item number                      9187083

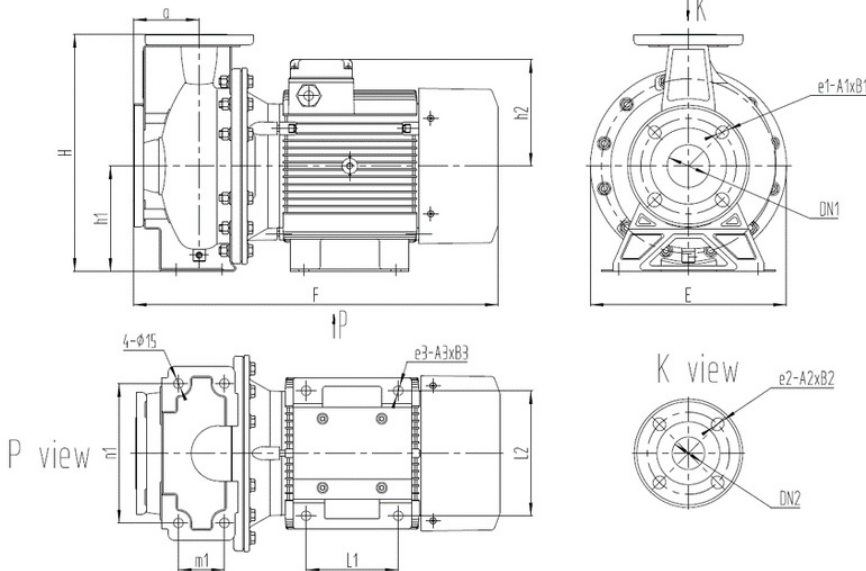

**Dimensions**

mm

A	100	B2	20	E	256	L1	140
A1	18	B3	20	F	581	L2	190
A2	18	dL	18	H	340	M1	95
A3	15	DN1	DN 80, P	H1	160	n1	212
B1	20	DN2	DN 65, P	H2	162	Ø k	160



Contact  
E-mail  
Phone

Customer

Contact  
E-mail  
Phone

# Hydraulic data

Glanded monobloc pump  
Atmos BST 65/125-7.5/2-V2

Project ID: Untitled project 2025-03-01 17:12:44.130

Project name  
Installation location  
Customer pos. No.

Date: 2025-03-01

## Operating data

Rotational speed <b>2927 1/min</b>	Frequency <b>50 Hz</b>	Duty point <b>Q =</b>	<b>H =</b>	Suction port <b>DN 80</b>	Discharge port <b>DN 65</b>
---------------------------------------	---------------------------	--------------------------	------------	------------------------------	--------------------------------

Power data referred to: Water; 20°C; 998.3kg/m³; 1.005mm²/s ±10 % tolerance with linear U/f frequency control

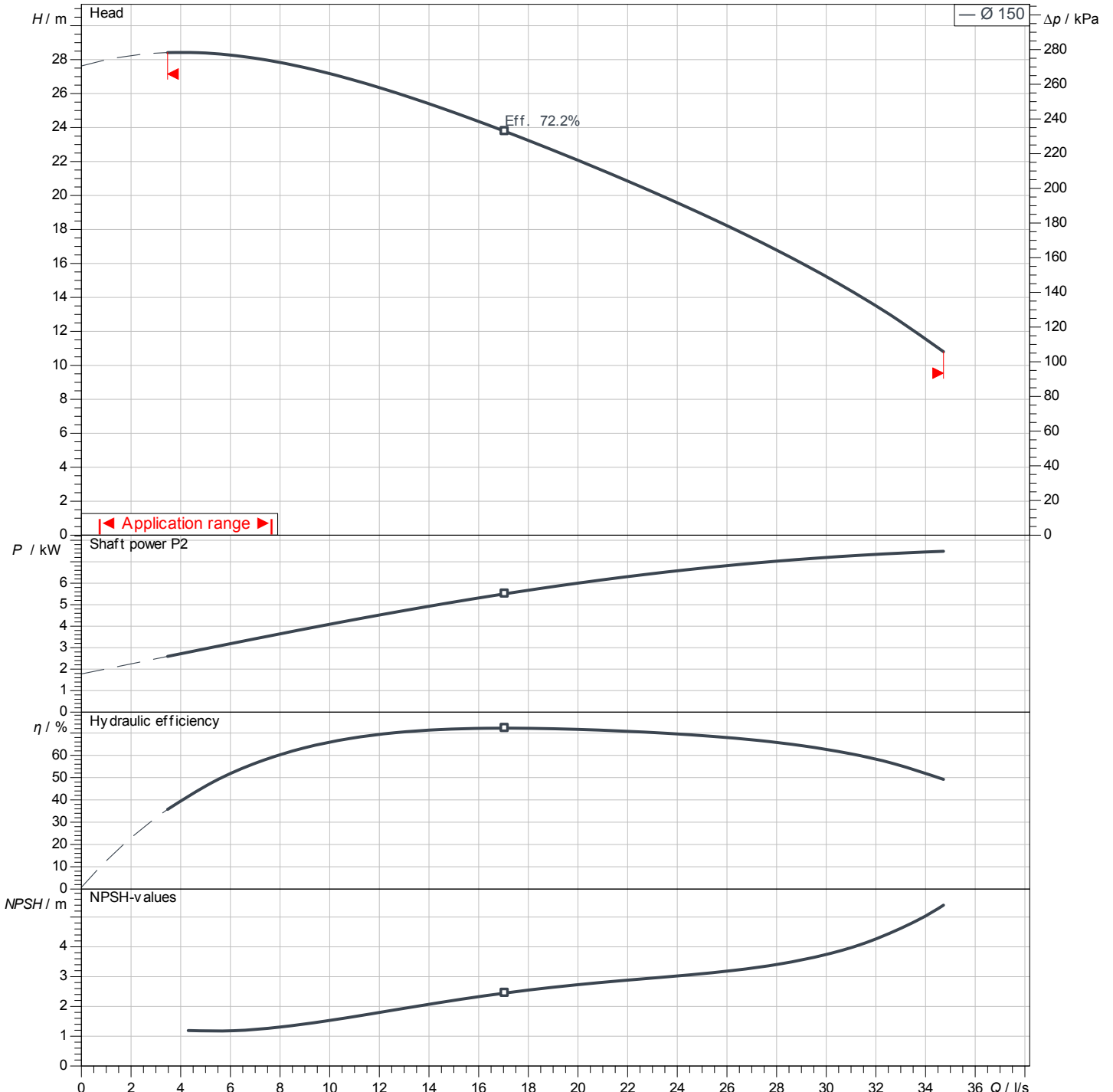

No test norm defined for this product

Contact  
E-mail  
Phone

**Customer**

Contact  
E-mail  
Phone

## Dimensions

Glanded monobloc pump  
Atmos BST 65/125-7.5/2-V2

Project ID                      Untitled project 2025-03-01 17:12:44.130

Project name  
Installation location  
Customer pos. No.

Date                      2025-03-01

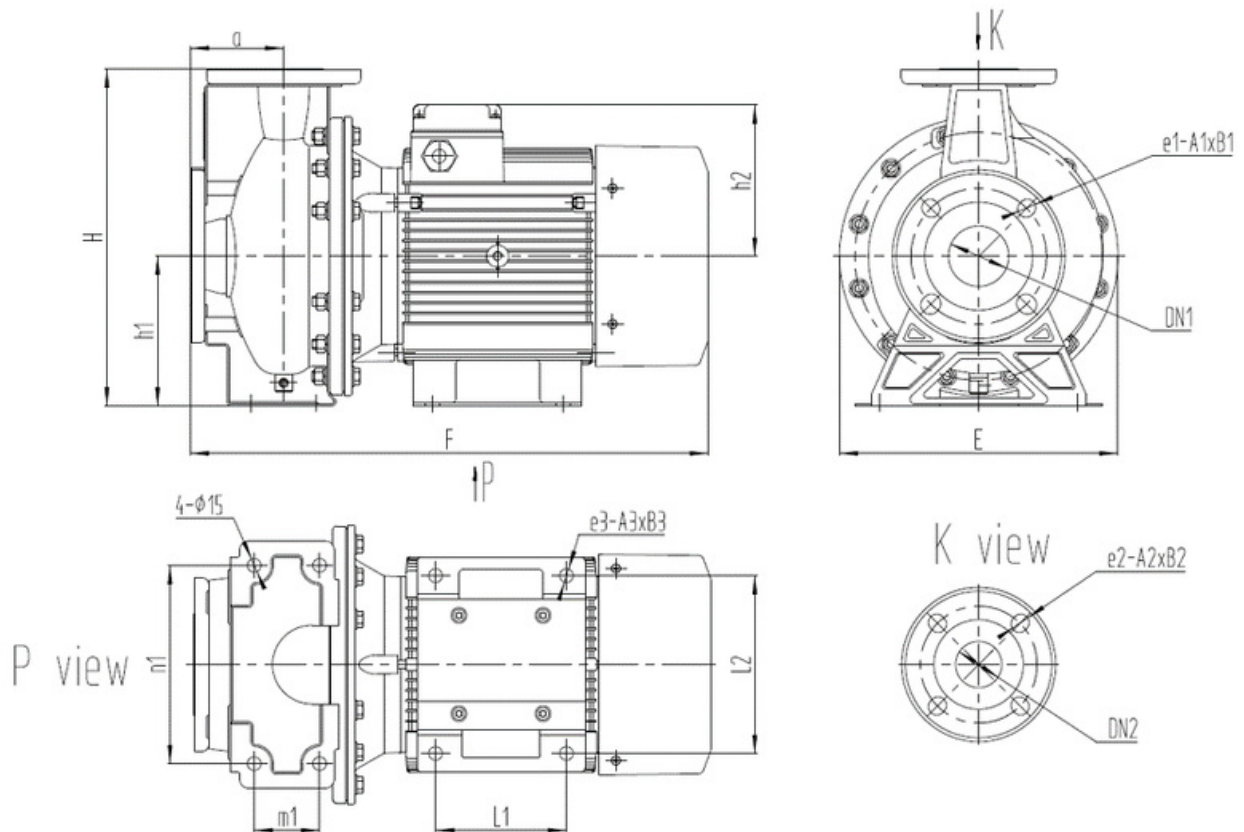

Standard

Suction side                      DN 80, PN 16

Discharge side                      DN 65, PN 16

**Dimensions**                      mm

Name	Value	Name	Value	Name	Value	Name	Value
A	100	dL	18	H2	162	Ø D	200
A1	18	DN1	DN 80, PN 16	L1	140		
A2	18	DN2	DN 65, PN 16	L2	190		
A3	15	E	256	M1	95		
B1	20	F	581	n1	212		
B2	20	H	340	Ø k	160		
B3	20	H1	160	Ø d	118		