

Customer

Technical data

High-pressure multistage centrifugal pump Helix VE 5205-2/25/V/KS/3

Project ID: Untitled project 2025-03-03 15:12:38.853

Project name
Installation location
Customer pos. No.

Date: 2025-03-03

Duty chart

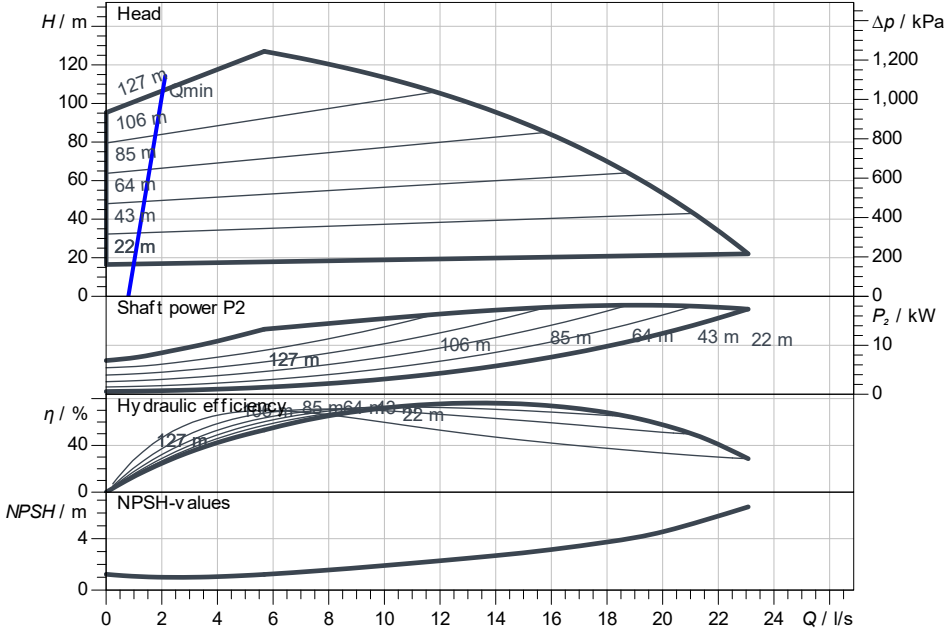

ISO 9906: 2012 3B

Dimensions

H	1,60
H2	1,11
ØM	217
X	386
X	386

mm

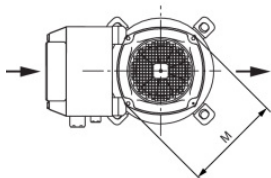
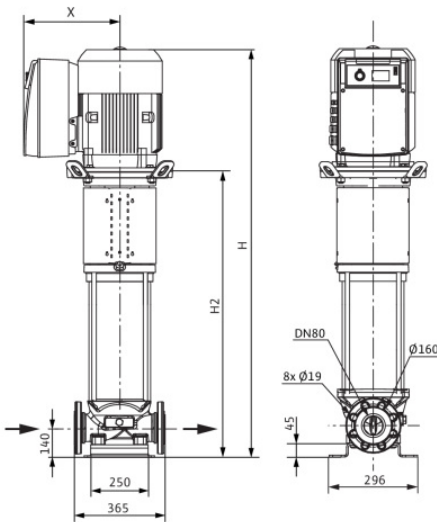
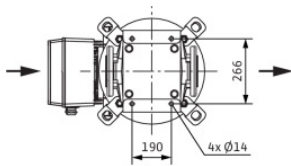

Requested data

Flow	
Head	
Media	Water 100 %
Fluid temperature	20.00 °C
Density	998.30 kg/m³
Kin. viscosity	1.00 mm²/s

Hydraulic data (Duty point)

Flow	
Head	
Shaft power P2	
Hydraulic efficiency	
NPSH	

Product data

High-pressure multistage centrifugal pump Helix VE 5205-2/25/V/KS/3	
Max. operating pressure	2,500 kPa
Inlet pressure max.	10 bar
Fluid temperature	-15 °C ... +90 °C
Max. ambient temperature	50 °C
Minimum efficiency index (MEI)	≥ 0.7

Motordata per Motor/Pump

Motor efficiency level	IE5
Mains connection	3~ 400 V / 50 Hz
Permitted voltage tolerance	

Rated speed	
Rated power P2	18.50 kW
Rated current	32.10 A
Power factor	
Service factor	0
Degree of protection	IP55
Insulation class	F
Motor protection	

Fitting dimensions

Pipe connection on the suction side	DN 80, PN 25
Pipe connection (pressure side)	DN 80, PN 25

Materials

Pump housing	1.4409
Impeller	1.4404
Shaft	1.4404
Shaft seal	BQ7VGG
Gasket material	FKM

Information for order placements

Weight approx.	243 kg
Item number	4256816