

Customer

Technical data

Glanded standard pump Atmos GIGA-NHT 32/160-5.5/2-S2

Project ID: Untitled project 2025-03-01 20:45:47.557

Project name
Installation location
Customer pos. No.

Date: 2025-03-01

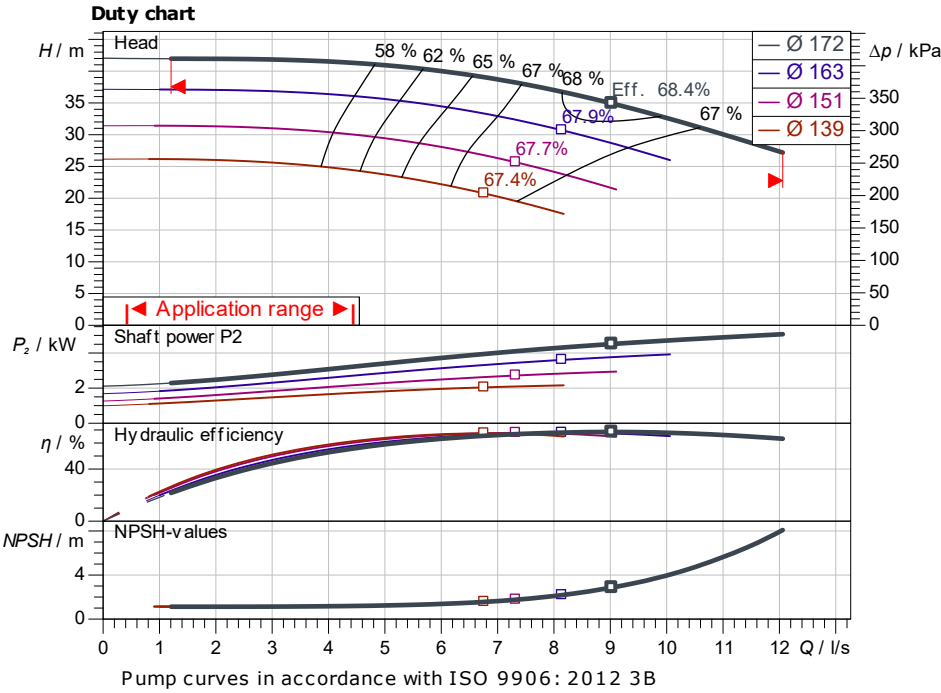

Requested data

Flow
Head
Media: Water 100 %
Fluid temperature: 20.00 °C
Density: 998.30 kg/m³
Kin. viscosity: 1.00 mm²/s

Hydraulic data (Duty point)

Flow
Head
Shaft power P_2
Hydraulic efficiency
NPSH
Impeller size: 172

Product data

Glanded standard pump
Atmos GIGA-NHT 32/160-5.5/2-S2
Max. operating pressure: 2,500 kPa
Fluid temperature: -20 °C ... +350 °C
Max. ambient temperature: 50 °C
Minimum efficiency index (MEI)

Motordata per Motor/Pump

Motor efficiency level: IE3
Mains connection: 3~ 400 V / 50 Hz
Permitted voltage tolerance: +10 %
Max. speed: 2,930 1/min
Rated power P_2 : 5.50 kW
Rated current: 10.60 A
Power factor: 0.78
Efficiency: 50% / 75% / 100% → 86.9/88.7/89.4%
Degree of protection: IP55
Insulation class: F
Motor protection: No

Fitting dimensions

Pipe connection on the suction side: DN 50, PN 25
Pipe connection (pressure side): DN 32, PN 25
Port to Port

Materials

Pump housing: EN-GJS-400-15
Impeller: EN-GJL-200
Shaft: 1.4028
Shaft seal: AQ1VGG

Information for order placements

Weight approx.
Item number: 6098341

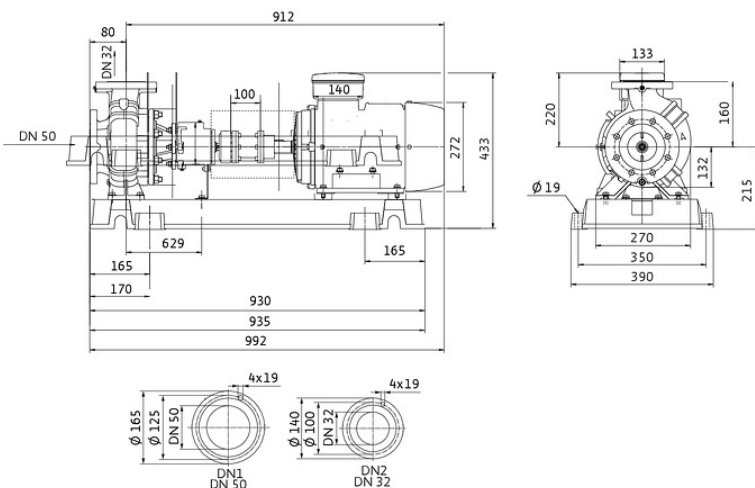

Dimensions: mm



Contact
E-mail
Phone

Customer

Contact
E-mail
Phone

Hydraulic data

Glanded standard pump
Atmos GIGA-NHT 32/160-5.5/2-S2

Project ID: Untitled project 2025-03-01 20:45:47.557

Project name
Installation location
Customer pos. No.

Date: 2025-03-01

Operating data

Rotational speed 2917 1/min	Frequency 50 Hz	Duty point Q =	H =	Suction port DN 50	Discharge port DN 32
---------------------------------------	---------------------------	--------------------------	------------	------------------------------	--------------------------------

Power data referred to: Water; 20°C; 998.3kg/m³; 1.005mm²/s ±10 % tolerance with linear U/f frequency control

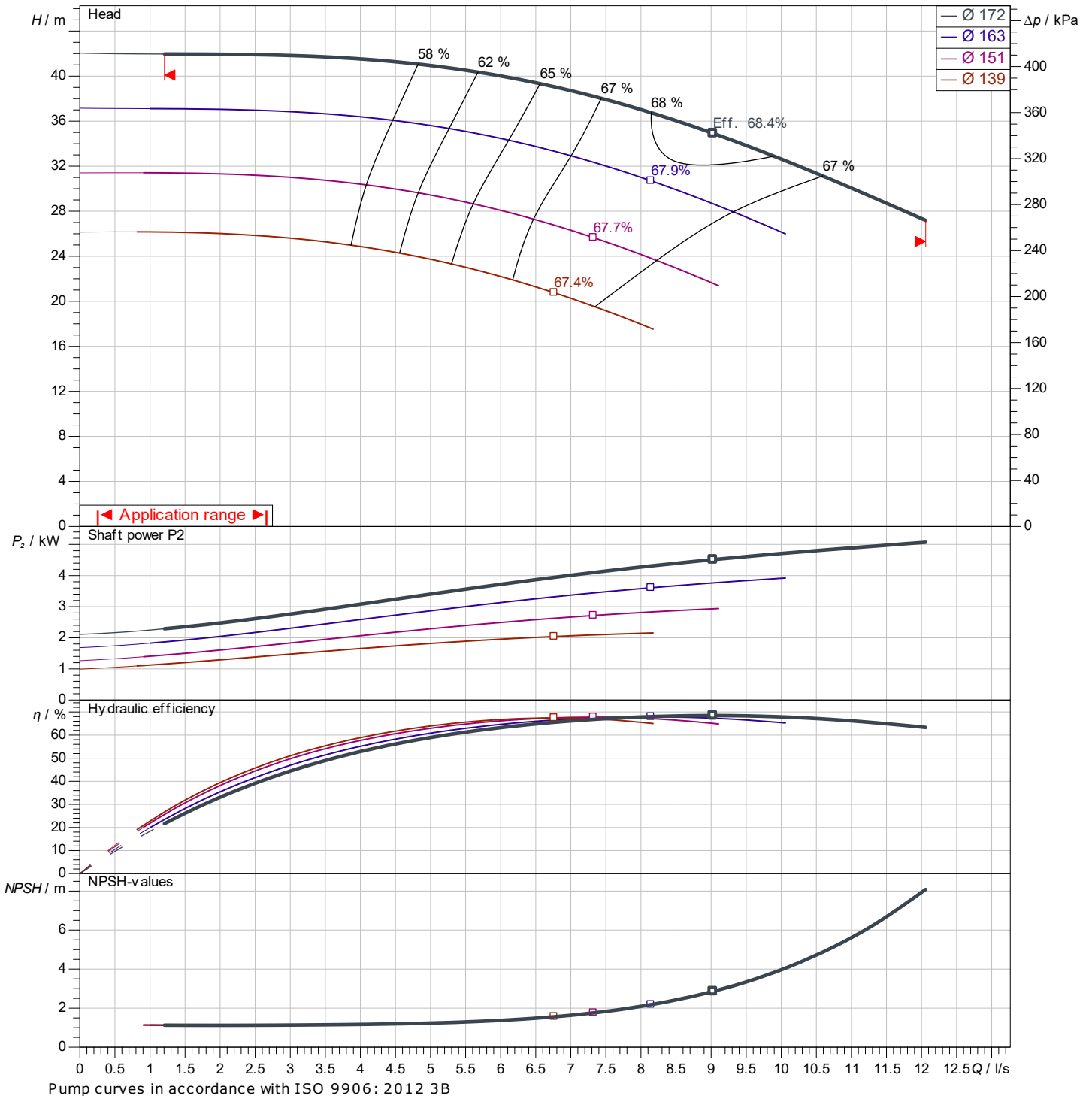

Pump curves in accordance with ISO 9906: 2012 3B

Contact
E-mail
Phone

Customer

Contact
E-mail
Phone

Dimensions

Glanded standard pump
Atmos GIGA-NHT 32/160-5.5/2-S2

Project ID Untitled project 2025-03-01 20:45:47.557

Project name
Installation location
Customer pos. No.

Date 2025-03-01

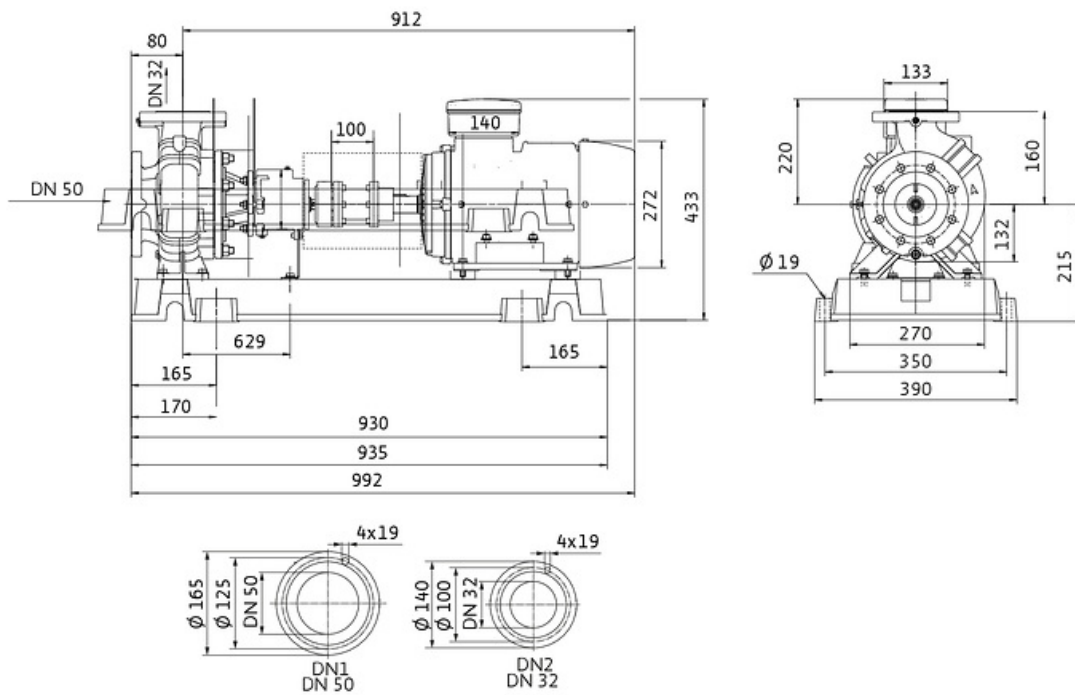

Standard

Suction side DN 50, PN 25

Discharge side DN 32, PN 25

Dimensions mm

Name	Value	Name	Value	Name	Value	Name	Value
------	-------	------	-------	------	-------	------	-------