

Customer

Technical data

High-pressure multistage centrifugal pump Helix V 409-2/25/V/KS/400-50

Project ID: Untitled project 2025-03-03 20:19:56.538

Project name
Installation location
Customer pos. No.

Date: 2025-03-03

Duty chart

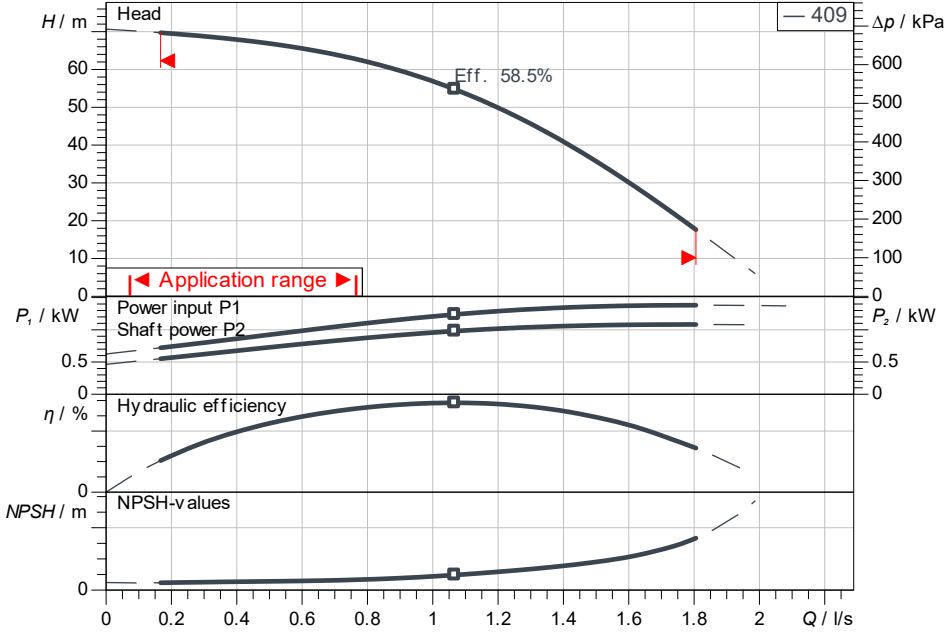

ISO 9906: 2012 3B

Dimensions

H	799
H2	571
ØM	170
X	136
X	115

mm

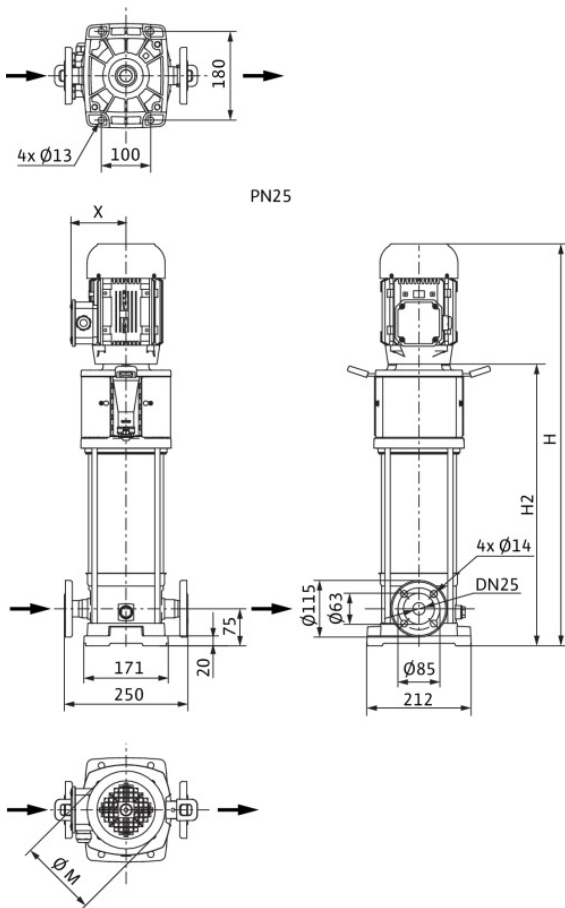

Requested data

Flow	
Head	
Media	Water 100 %
Fluid temperature	20.00 °C
Density	998.30 kg/m³
Kin. viscosity	1.00 mm²/s

Hydraulic data (Duty point)

Flow	
Head	
Shaft power P2	
Hydraulic efficiency	
NPSH	

Product data

High-pressure multistage centrifugal pump Helix V 409-2/25/V/KS/400-50	
Max. operating pressure	2,500 kPa
Inlet pressure max.	10 bar
Fluid temperature	-15 °C ... +90 °C
Max. ambient temperature	50 °C
Minimum efficiency index (MEI)	≥ 0.7

Motordata per Motor/Pump

Motor efficiency level	IE3
Mains connection	3~ 400 V / 50 Hz
Permitted voltage tolerance	+ -10 %
Max. speed	2,900 1/min
Rated power P2	1.10 kW
Rated current	2.50 A
Power factor	0.8
Service factor	1.15
Efficiency	50% / 75% / 100%
Degree of protection	IP55
Insulation class	F
Motor protection	No

Fitting dimensions

Pipe connection on the suction side	DN 25, PN 25
Pipe connection (pressure side)	DN 25, PN 25

Materials

Pump housing	1.4404
Impeller	1.4404
Shaft	1.4404
Shaft seal	BQ7VGG
Gasket material	FKM

Information for order placements

Weight approx.	35 kg
Item number	4160556