

Customer

Technical data

Non self-priming multistage centrifugal pump MHI 402-2/V/1-230-50-2

Project ID: Untitled project 2025-03-03 06:59:09.769

Project name
Installation location
Customer pos. No.

Date: 2025-03-03

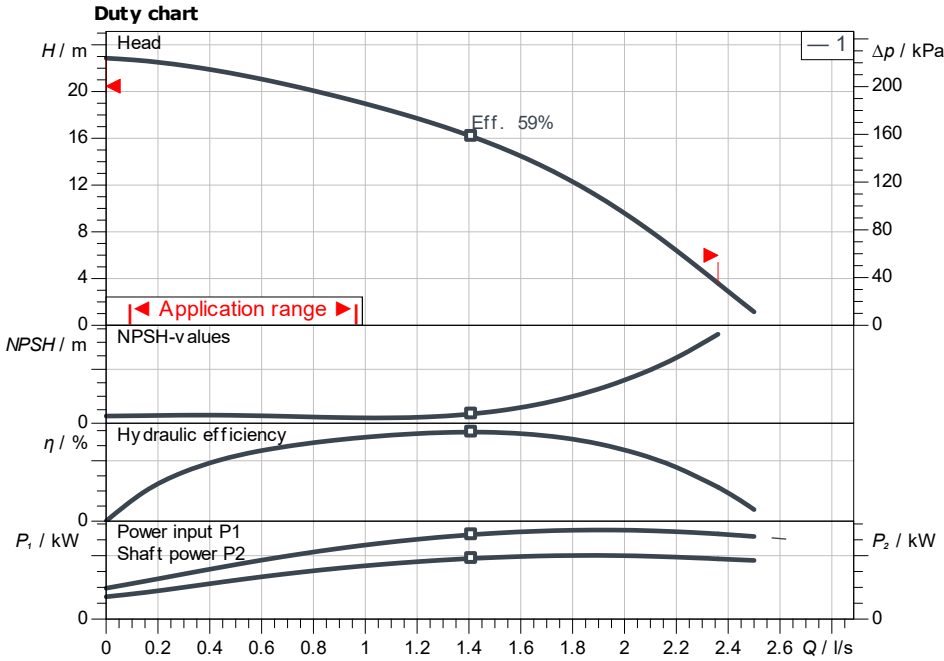

ISO 9906: 2012 3B

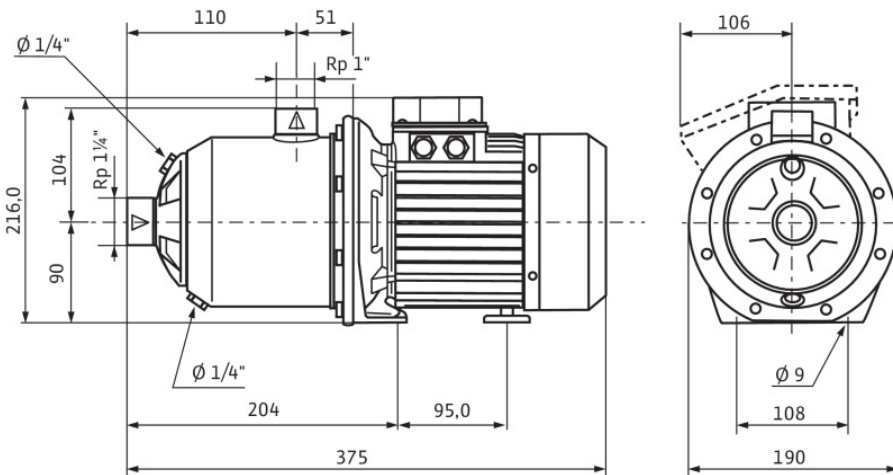

Dimensions mm

Requested data

Flow	
Head	
Media	Water 100 %
Fluid temperature	20.00 °C
Density	998.30 kg/m ³
Kin. viscosity	1.00 mm ² /s

Hydraulic data (Duty point)

Flow	
Head	
Shaft power P2	
Hydraulic efficiency	
NPSH	

Product data

Non self-priming multistage centrifugal pump MHI 402-2/V/1-230-50-2	
Max. operating pressure	1,000 kPa
Inlet pressure max.	6 bar
Fluid temperature	-15 °C ... +90 °C
Max. ambient temperature	40 °C

Motordata per Motor/Pump

Motor efficiency level	IE1
Mains connection	1~ 230 V / 50 Hz
Permitted voltage tolerance	+ -10 %
Max. speed	2,810 1/min
Rated power P2	0.55 kW
Rated current	4.00 A
Power factor	0.97
Efficiency	59.2/75% / 100%
Degree of protection	X4
Insulation class	F
Motor protection	

Fitting dimensions

Pipe connection on the suction side	Rp 1 1/4, PN 10
Pipe connection (pressure side)	Rp 1, PN 10

Materials

Pump housing	1.4404
Impeller	1.4404
Shaft	1.4404
Shaft seal	BQ7VGG
Gasket material	FKM

Information for order placements

Weight approx.	9.8 kg
Item number	4015686