

**Customer**

## Technical data

### High-pressure multistage centrifugal pump Medana CH1-L.602-2/V/A/10T

Project ID                      Untitled project 2025-03-03 23:00:00.495

Project name  
Installation location  
Customer pos. No.

Date                      2025-03-03

#### Duty chart

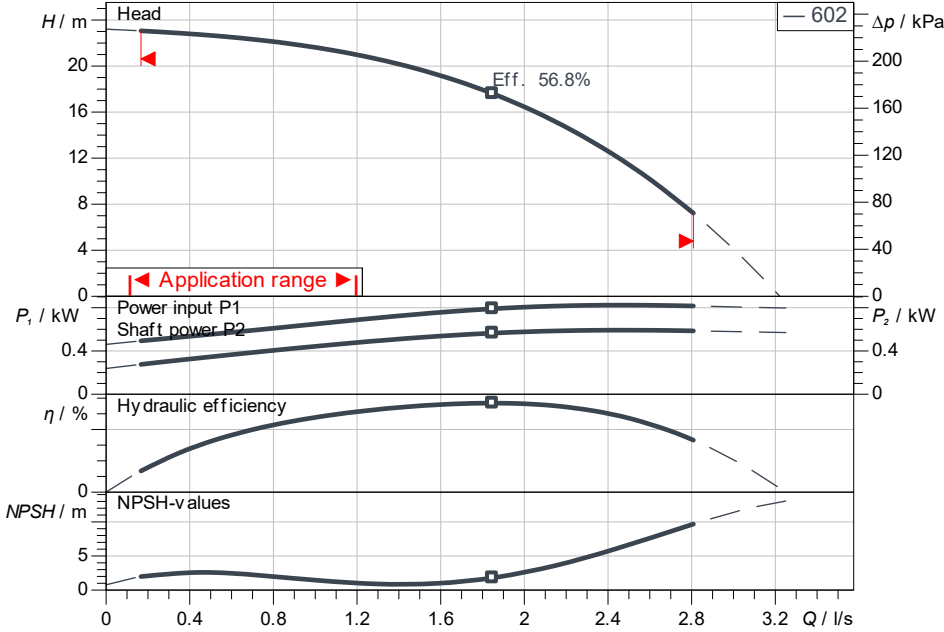

#### Requested data

Flow	
Head	
Media	Water 100 %
Fluid temperature	20.00 °C
Density	998.30 kg/m <sup>3</sup>
Kin. viscosity	1.00 mm <sup>2</sup> /s

#### Hydraulic data (Duty point)

Flow  
Head

#### Product data

High-pressure multistage centrifugal pump Medana CH1-L.602-2/V/A/10T	
Max. operating pressure	1,000 kPa
Inlet pressure max.	600 kPa
Fluid temperature	-20 °C ... +90 °C
Max. ambient temperature	50 °C

#### Motordata per Motor/Pump

Motor efficiency class	IE2
Mains connection	1~ 230 V / 50 Hz
Permitted voltage tolerance	+ -10 %
Max. speed	2,900 1/min
Rated power P2	0.55 kW
Rated current	3.60 A
0	
Degree of protection	IP55
Insulation class	F
Motor protection	No

#### Fitting dimensions

Pipe connection on the suction side	Rp 1 1/4, PN 10
Pipe connection (pressure side)	Rp 1, PN 10

#### Materials

Pump housing	1.4404
Impeller	1.4404
Shaft	1.4404
Shaft seal	BQ1VGG
Gasket material	FKM
Stage chamber material	1.4404

#### Information for order placements

Weight approx.	9.9 kg
Item number	4235348

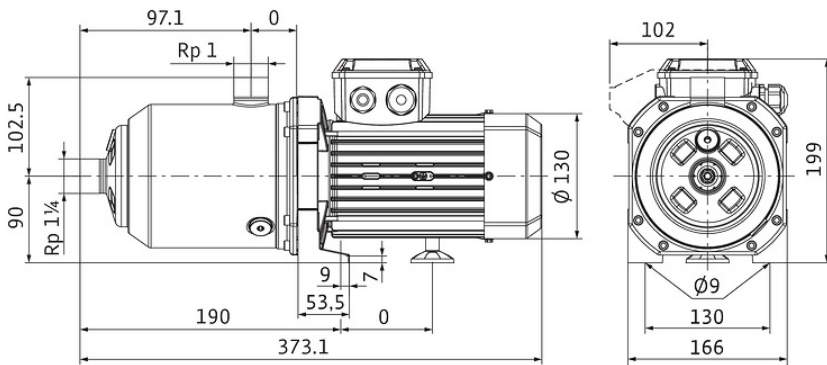

#### Dimensions                      mm