

Customer

Technical data

High-pressure multistage centrifugal pump HiMulti 3C1-45-P

Project ID Untitled project 2025-03-03 15:12:38.853

Project name
Installation location
Customer pos. No.

Date 2025-03-03

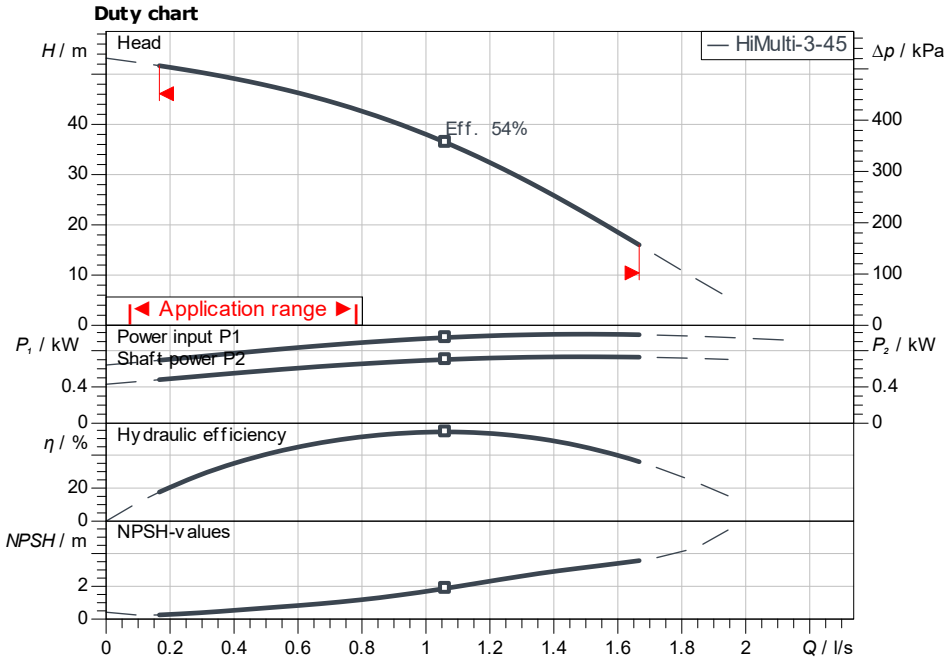

Requested data

Flow	
Head	
Media	Water 100 %
Fluid temperature	20.00 °C
Density	998.30 kg/m ³
Kin. viscosity	1.00 mm ² /s

Hydraulic data (Duty point)

Flow
Head

Product data

High-pressure multistage centrifugal pump	
HiMulti 3C1-45-P	
Max. operating pressure	800 kPa
Inlet pressure max.	300 kPa
Fluid temperature	0 °C ... +40 °C
Max. ambient temperature	40 °C
Protection class	X4

Motordata per Motor/Pump

Mains connection	1 ~ 230 V / 50 Hz
Permitted voltage tolerance	+10/-15 %
Max. speed	2,900 1/min
Rated power P2	0.80 kW
Rated current	4.60 A
	0

Insulation class	F
Motor protection	PTO

Fitting dimensions

Pipe connection on the suction side	G 1, PN 8
Pipe connection (pressure side)	G 1, PN 10

Materials

Shaft	1.4021
Shaft seal	BVPFF
Gasket material	EPDM
Stage chamber material	PPE/PS-GF30

Information for order placements

Weight approx.	12.7 kg
Item number	2543602

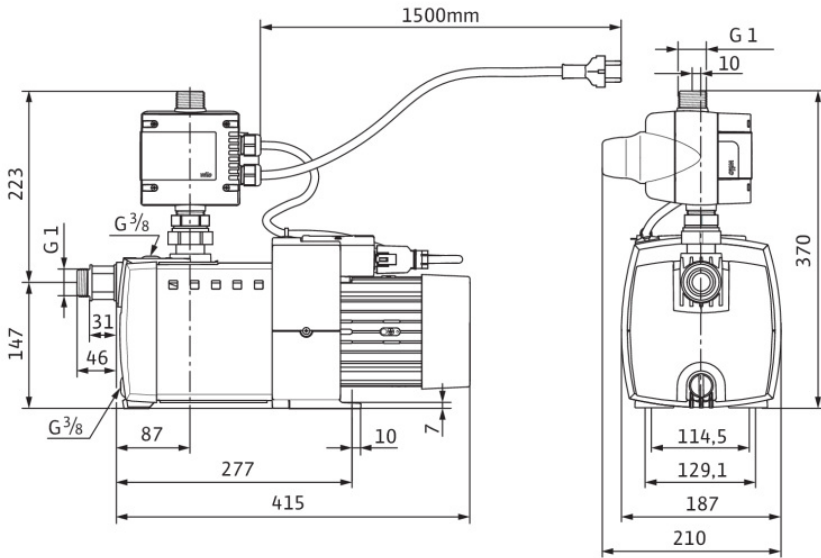

Dimensions mm