

Customer

Technical data

Glanded standard pump Atmos GIGA-N 125/200-15/4-IE4

Project ID: Untitled project 2025-03-03 06:26:03.775

Project name
Installation location
Customer pos. No.

Date: 2025-03-03

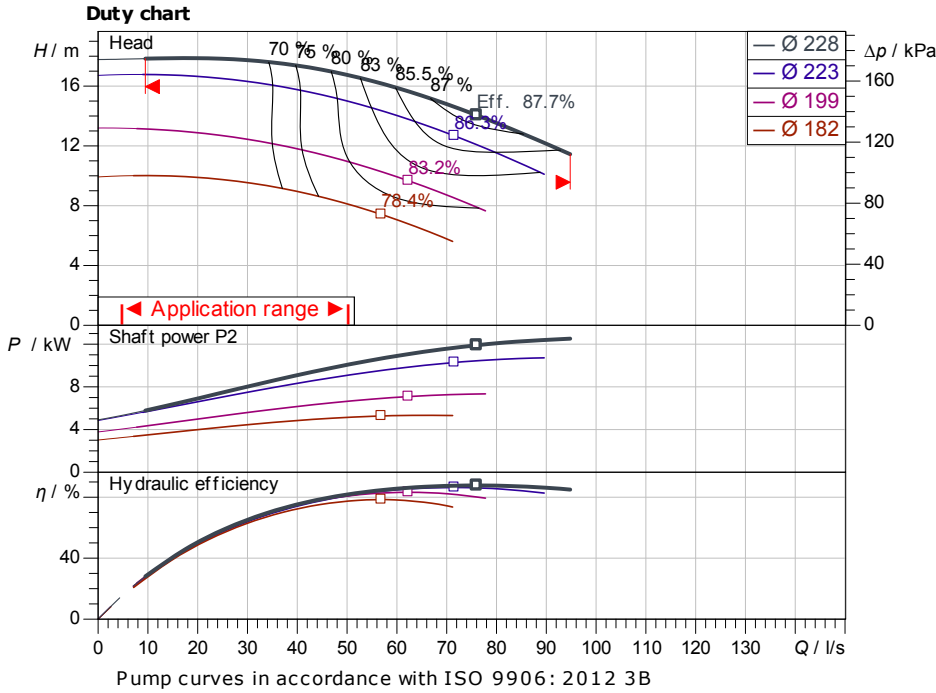

Requested data

Flow
Head
Media: Water 100 %
Fluid temperature: 20.00 °C
Density: 998.30 kg/m³
Kin. viscosity: 1.00 mm²/s

Hydraulic data (Duty point)

Flow
Head
Shaft power P_2
Hydraulic efficiency
NPSH
Impeller size: 228

Product data

Glanded standard pump
Atmos GIGA-N 125/200-15/4-IE4
Max. operating pressure: 1,600 kPa
Fluid temperature: -20 °C ... +140 °C
Max. ambient temperature: 40 °C
Minimum efficiency index (MEI): ≥ 0.4

Motordata per Motor/Pump

Motor efficiency level: IE4
Mains connection: 3~ 400 V / 50 Hz
Permitted voltage tolerance: +10 %
Max. speed: 1,475 1/min
Rated power P_2 : 15.00 kW
Rated current: 28.50 A
Power factor: 0.81
Efficiency: 50% / 75% / 100%: 92.7/93.6/93.9%
Degree of protection: IP55
Insulation class: F
Motor protection: PTC integrated

Fitting dimensions

Pipe connection on the suction side: DN 150, PN 16
Pipe connection (pressure side): DN 125, PN 16
Port to Port

Materials

Pump housing: 5.1301/EN-GJL-250
Impeller: EN-GJL-200
Lantern: 5.1301/EN-GJL-250
Shaft: 1.4021
Shaft seal: AQ1EGG

Information for order placements

Weight approx.: 421.6 kg
Item number

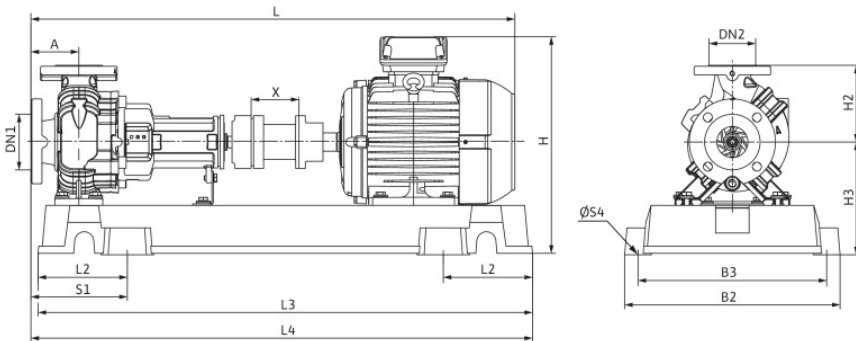

Dimensions

mm

A	140	H	619	L3	1,440
B2	610	H2	315	L4	1,470
B3	550	H3	353	S1	280
DN1	DN 150,	L	1,426	S4	29
DN2	DN 125,	L2	250	X	140



Contact
E-mail
Phone

Customer

Contact
E-mail
Phone

Hydraulic data

Glanded standard pump
Atmos GIGA-N 125/200-15/4-IE4

Project ID: Untitled project 2025-03-03 06:26:03.775

Project name
Installation location
Customer pos. No.

Date: 2025-03-03

Operating data

Rotational speed 1467 1/min	Frequency 50 Hz	Duty point Q =	H =	Suction port DN 150	Discharge port DN 125
---------------------------------------	---------------------------	--------------------------	------------	-------------------------------	---------------------------------

Power data referred to: Water; 20°C; 998.3kg/m³; 1.005mm²/s ±10 % tolerance with linear U/f frequency control

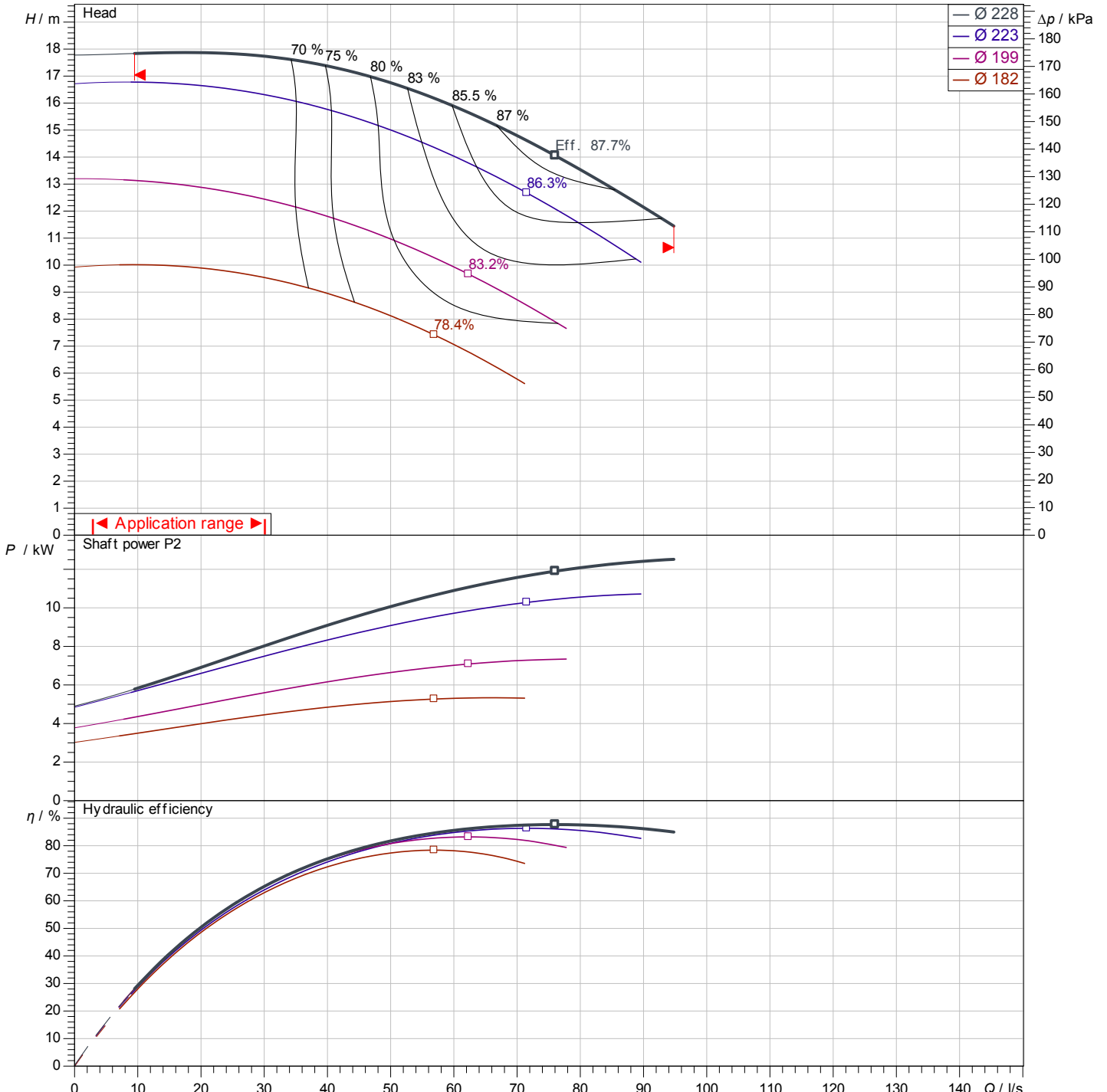

Pump curves in accordance with ISO 9906: 2012 3B

Contact
E-mail
Phone

Customer

Contact
E-mail
Phone

Dimensions

Glanded standard pump
Atmos GIGA-N 125/200-15/4-IE4

Project ID Untitled project 2025-03-03 06:26:03.775

Project name
Installation location
Customer pos. No.

Date 2025-03-03



Coupling with spacer

Suction side DN 150, PN 16
Discharge side DN 125, PN 16

Dimensions mm

Name	Value	Name	Value	Name	Value	Name	Value
A	140	H3	353	X	140		
B2	610	L	1,426				
B3	550	L2	250				
DN1	DN 150, PN 16	L3	1,440				
DN2	DN 125, PN 16	L4	1,470				
H	619	S1	280				
H2	315	S4	29				