

Customer

Dimensions

Glanded monobloc pump
BM-S 50/225-17/2

Project ID

Untitled project 2025-03-01 21:27:50.947

Project name

Installation location

Customer pos. No.

Date 2025-03-01

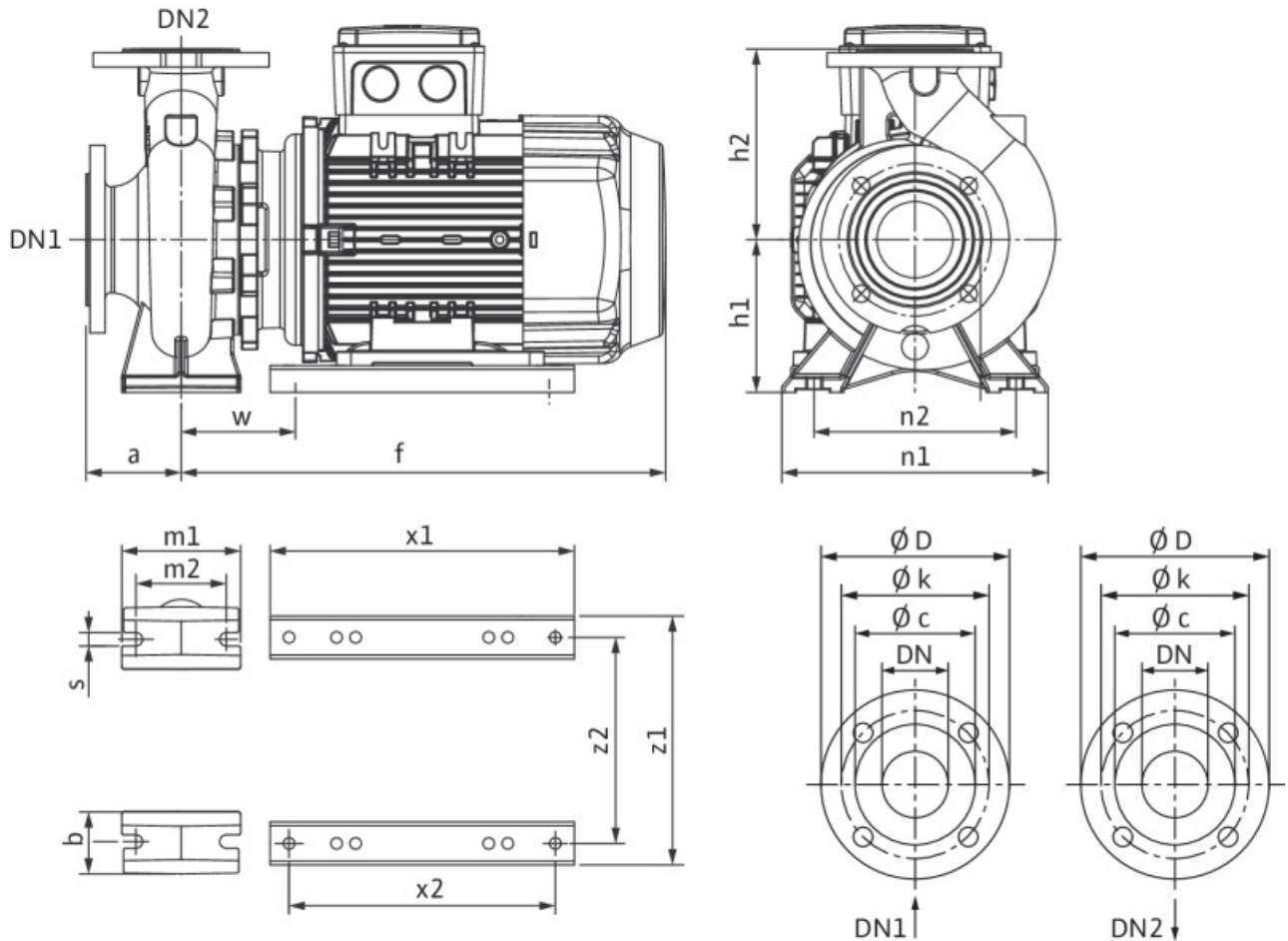

Standard

Suction side DN 65, PN 10
Discharge side DN 50, PN 10

Dimensions mm

Name	Value	Name	Value	Name	Value	Name	Value
a	100	h1	180	Ø k	125	z1	261
b	65	h2	225	ØD	185	z2	216
d	12	m1	125	ØD	165		
dL	18	m2	95	s	14		
DN1	DN 65, PN 10	n1	320	w	113		
DN2	DN 50, PN 10	n2	250	x1	320		
f	564	Ø k	145	x2	280		

Customer

Technical data

Glanded monobloc pump BM-S 50/225-17/2

Project ID Untitled project 2025-03-01 21:27:50.947

Project name
Installation location
Customer pos. No.

Date 2025-03-01

Duty chart

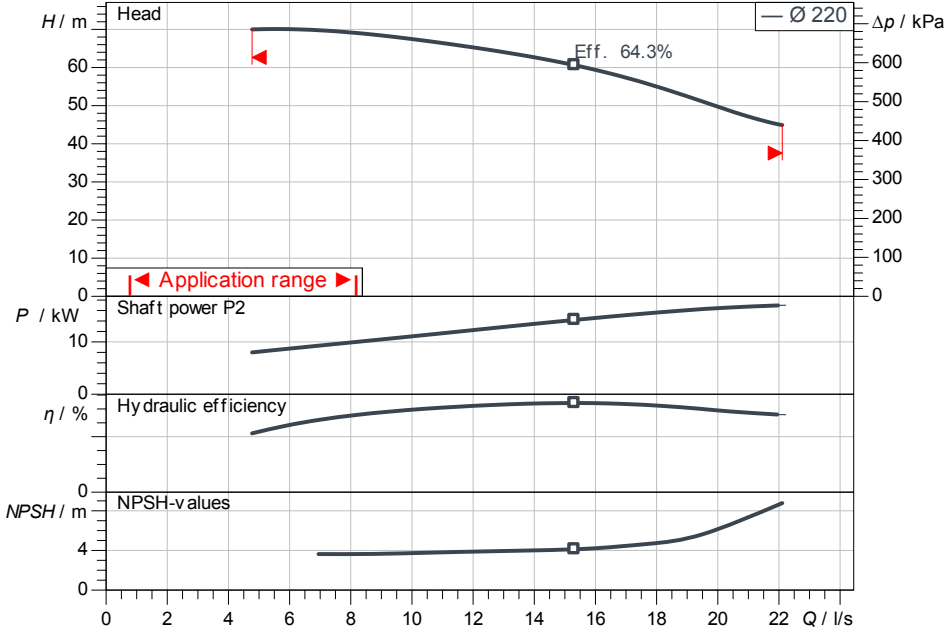

Requested data

Flow
Head
Media Water 100 %
Fluid temperature 20.00 °C
Density 998.30 kg/m³
Kin. viscosity 1.00 mm²/s

Hydraulic data (Duty point)

Flow
Head
Shaft power P2
Hydraulic efficiency
NPSH

Product data

Glanded monobloc pump
BM-S 50/225-17/2
Max. operating pressure 1,000 kPa
Fluid temperature -10 °C ... +90 °C
Max. ambient temperature 40 °C
Minimum efficiency index (MEI) ≥ 0.4

Motordata per Motor/Pump

Motor efficiency level IE3
Mains connection 3~ 400 V / 50 Hz
Permitted voltage tolerance + -10 %
Rated speed 2,900 1/min
Rated power P2 17.00 kW
Rated current 30.20 A
Power factor 0.89
Efficiency
50% / 75% / 100% 92.2/ 92.6/92.2 %
Degree of protection IP55
Insulation class F
Motor protection No

Fitting dimensions

Pipe connection on the suction side DN 65, PN 10
Pipe connection (pressure side) DN 50, PN 10
Port to Port -

Materials

Pump housing 1.4408
Impeller 1.4408
Shaft 1.4362
Shaft seal Q1Q1VGG

Information for order placements

Weight approx. 117 kg
Item number 2103442

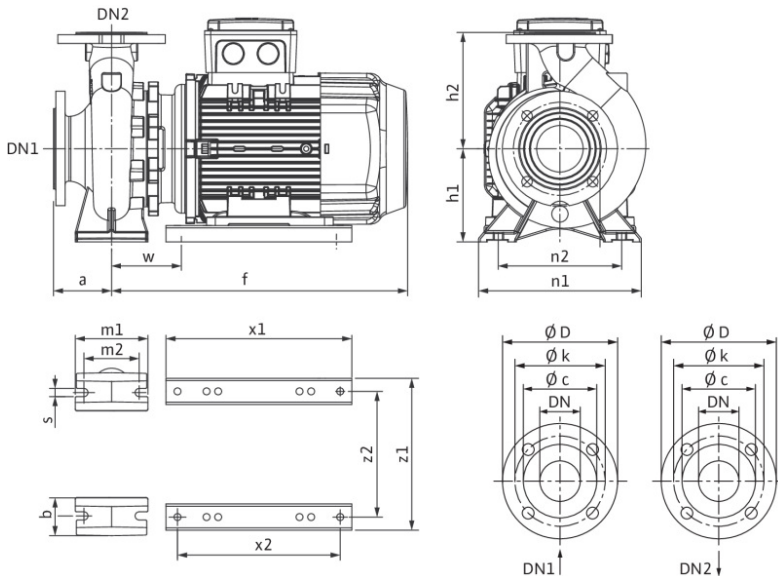

Hydraulic data

Glanded monobloc pump
BM-S 50/225-17/2

Project ID: Untitled project 2025-03-01 21:27:50.947

Project name
Installation location
Customer pos. No.

Date 2025-03-01

Operating data

Rotational speed 2900 1/min	Frequency 50 Hz	Duty point Q =	H =	Suction port DN 65	Discharge port DN 50
---------------------------------------	---------------------------	--------------------------	------------	------------------------------	--------------------------------

Power data referred to: Water; 20°C; 998.3kg/m³; 1.005mm²/s ±10 % tolerance with linear U/f frequency control

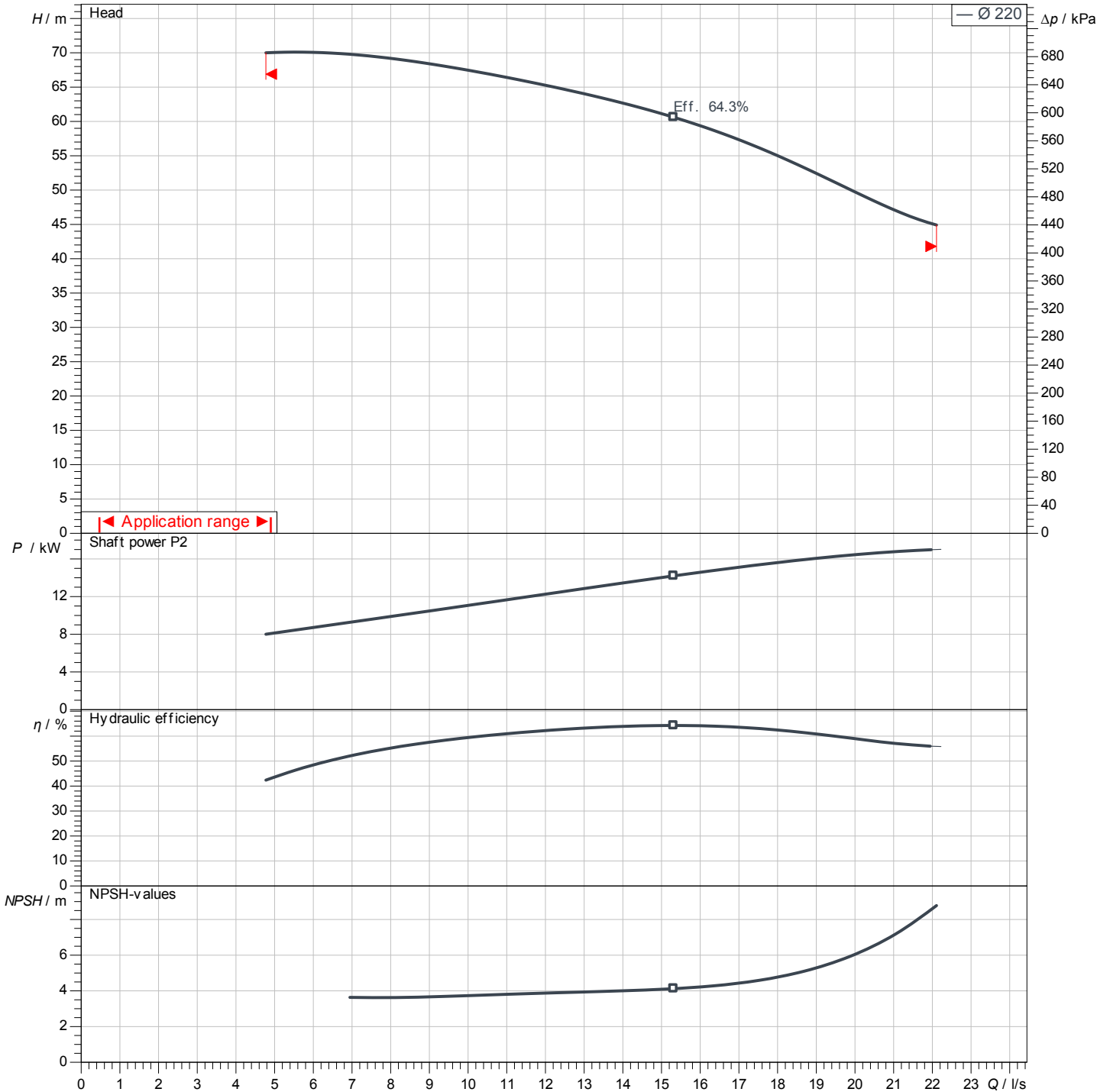

No test norm defined for this product