

Contact  
E-mail  
Phone

**Customer**

Contact  
E-mail  
Phone

## Technical data

Glanded standard pump  
Atmos GIGA-N 40/315-7.5/4

Project ID                      Untitled project 2025-03-03 06:26:03.775

Project name  
Installation location  
Customer pos. No.

Date                      2025-03-03

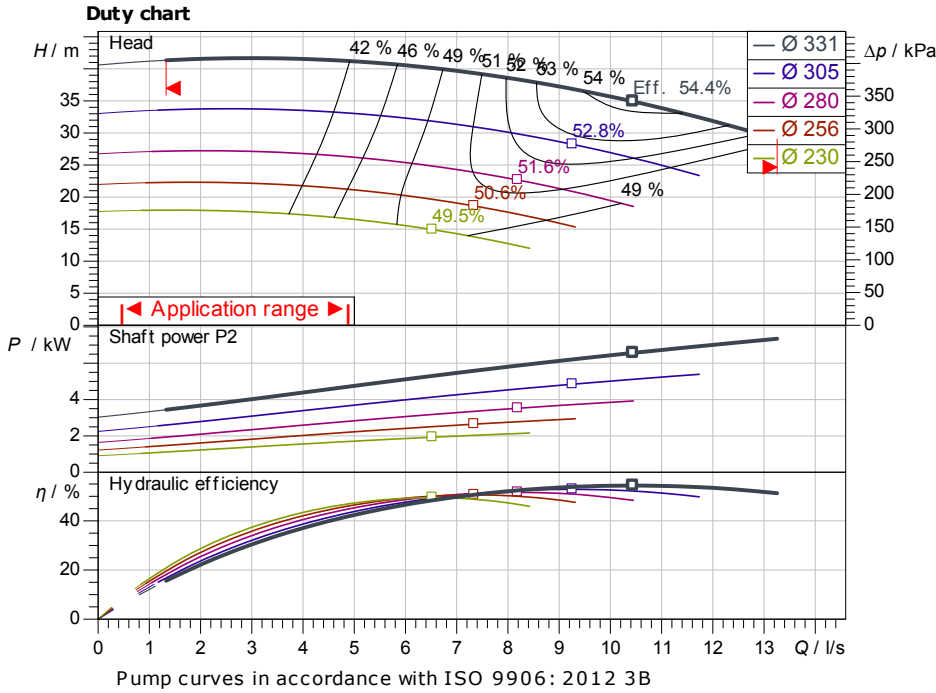

**Requested data**

Flow  
Head  
Media                      Water 100 %  
Fluid temperature       20.00 °C  
Density                    998.30 kg/m<sup>3</sup>  
Kin. viscosity            1.00 mm<sup>2</sup>/s

**Hydraulic data (Duty point)**

Flow  
Head  
Shaft power P2  
Hydraulic efficiency  
NPSH  
Impeller size            331

**Product data**

Glanded standard pump  
Atmos GIGA-N 40/315-7.5/4  
Max. operating pressure   1,600 kPa  
Fluid temperature       -20 °C ... +140 °C  
Max. ambient temperature   40 °C  
Minimum efficiency index (MEI)   ≥ 0.4

**Motordata per Motor/Pump**

Motor efficiency level       IE3  
Mains connection        3~ 400 V / 50 Hz  
Permitted voltage tolerance   + -10 %  
Max. speed                1,460 1/min  
Rated power P2            7.50 kW  
Rated current             13.90 A  
Power factor              0.8  
Efficiency  
50% / 75% / 100%        90.5/90.8/90.6%  
Degree of protection       IP55  
Insulation class         F  
Motor protection         No

**Fitting dimensions**

Pipe connection on the suction side   DN 65, PN 16  
Pipe connection (pressure side)   DN 40, PN 16  
Port to Port

**Materials**

Pump housing               5.1301, EN-GJL-250 c  
  
Impeller                    EN-GJL-200  
Lantern                    5.1301/EN-GJL-250  
Shaft                      1.4021  
Shaft seal                 AQ1EGG

**Information for order placements**

Weight approx.            272 kg  
Item number                6086506

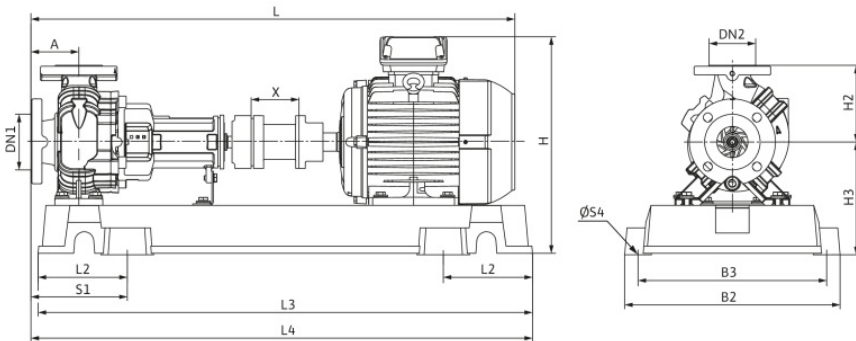

**Dimensions**

mm

A	125	H	546	L3	1,150
B2	490	H2	250	L4	1,185
B3	440	H3	328	S1	240
DN1	DN 65, P	L	1,185	S4	24
DN2	DN 40, P	L2	205	X	100

**Customer**

## Hydraulic data

Glanded standard pump  
Atmos GIGA-N 40/315-7.5/4

Project ID: Untitled project 2025-03-03 06:26:03.775

Project name  
Installation location  
Customer pos. No.

Date 2025-03-03

### Operating data

Rotational speed <b>1462 1/min</b>	Frequency <b>50 Hz</b>	Duty point <b>Q =</b>	<b>H =</b>	Suction port <b>DN 65</b>	Discharge port <b>DN 40</b>
---------------------------------------	---------------------------	--------------------------	------------	------------------------------	--------------------------------

Power data referred to: Water; 20°C; 998.3kg/m³; 1.005mm²/s ±10 % tolerance with linear U/f frequency control

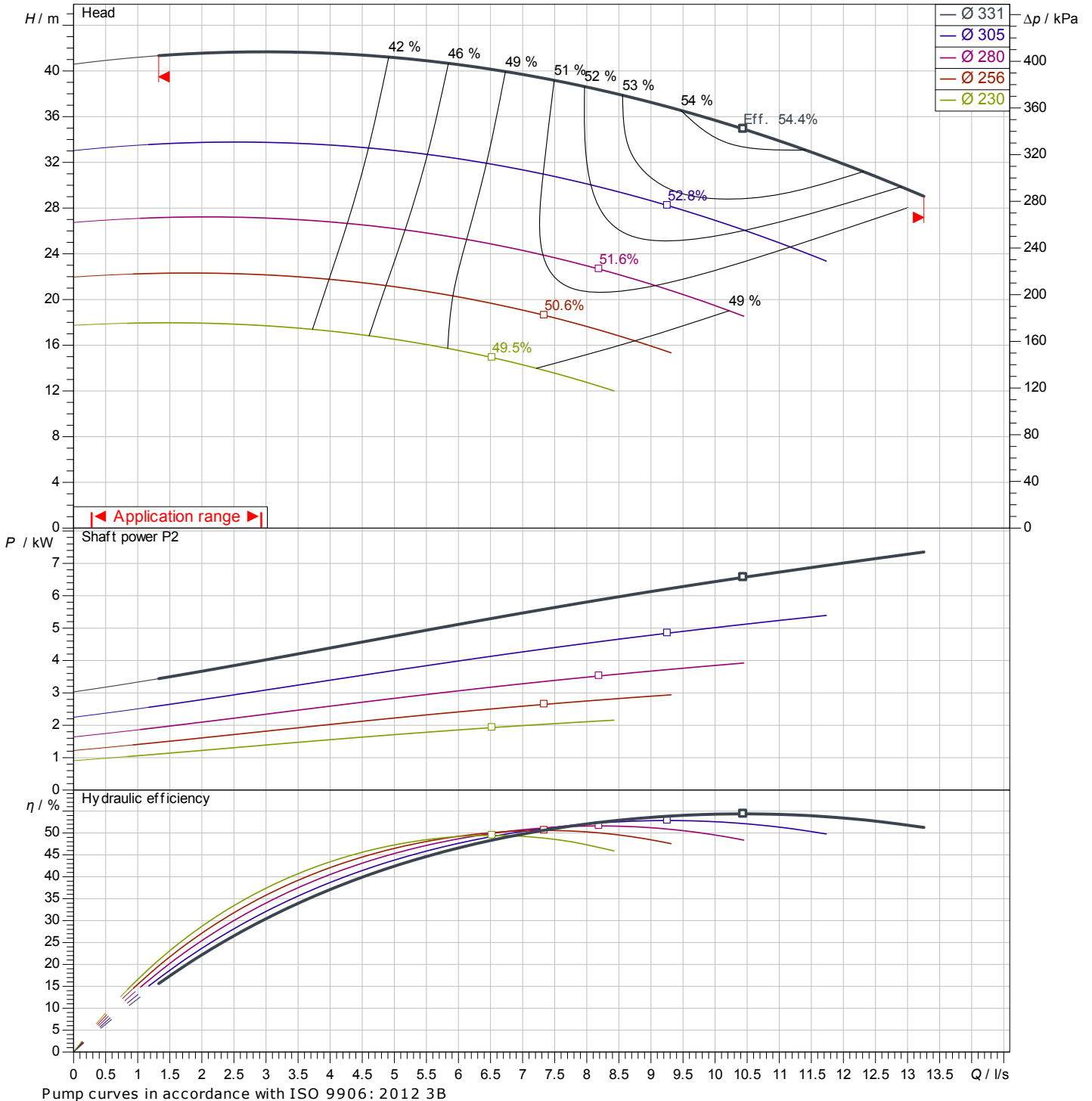

Contact  
E-mail  
Phone

**Customer**

Contact  
E-mail  
Phone

## Dimensions

Glanded standard pump  
Atmos GIGA-N 40/315-7.5/4

Project ID                      Untitled project 2025-03-03 06:26:03.775

Project name  
Installation location  
Customer pos. No.

Date                      2025-03-03



Coupling with spacer

Suction side                      DN 65, PN 16  
Discharge side                      DN 40, PN 16

**Dimensions**                      mm

Name	Value	Name	Value	Name	Value	Name	Value
A	125	H3	328	X	100		
B2	490	L	1,185				
B3	440	L2	205				
DN1	DN 65, PN 16	L3	1,150				
DN2	DN 40, PN 16	L4	1,185				
H	546	S1	240				
H2	250	S4	24				