

**Customer**

## Technical data

### Submersible pump Sub TWU 4.08-15-EM-C

Project ID                      Untitled project 2025-03-17 08:16:17.345

Project name  
Installation location  
Customer pos. No.

Date                      2025-03-17

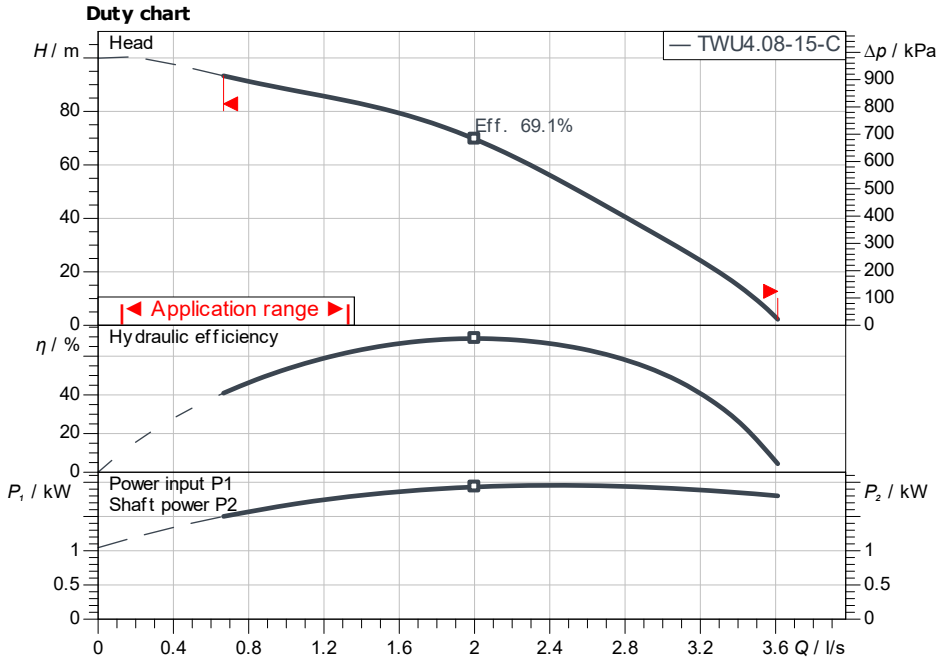

**Requested data**

Flow	
Head	
Media	Water 100 %
Fluid temperature	20.00 °C
Density	998.30 kg/m <sup>3</sup>
Kin. viscosity	1.00 mm <sup>2</sup> /s

**Hydraulic data (Duty point)**

Flow	
Head	
Shaft power P2	
Hydraulic efficiency	
Power input P1	

**Product data**

Submersible pump	
Sub TWU 4.08-15-EM-C	
Max. operating pressure	1,100 kPa
Fluid temperature	3 °C ... +30 °C
Minimum efficiency index (MEI)	≥ 0.4
Max. pump diameter	98 mm

**Motordata per Motor/Pump**

Mains connection	1~ 230 V / 50 Hz
Type of motor	Submersible motor
Activation type	Direct On Line (DOL)
Min. flow at the motor	0.08 m/s
Motor diameter	98 mm
Permitted voltage tolerance	+5 %
Nominal speed	2,869 1/min
Rated power P2	2.20 kW
Rated current	14.80 A
Power factor	0.94
Degree of protection	IP68
Insulation class	B

**Cable**

Length of connecting cable	2.5 m
Cable type	4G1,5

**Fitting dimensions**

Discharge size	Rp 2
Flange standard	-

**Materials**

Pump housing	1.4301
Motor housing	1.4301
Shaft	1.4104
Impeller	PPE

**Information for order placements**

Weight approx.	22.5 kg
Item number	6081622

**Approval**

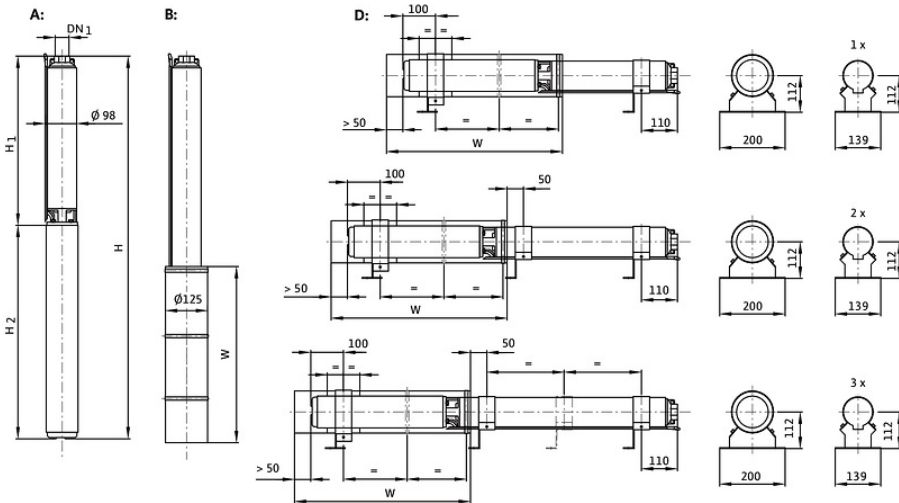

**Dimensions**

		mm	
H	1,070	W	500
H1	640		
H2	430		
H2	430		