

Contact
E-mail
Phone

Customer

Contact
E-mail
Phone

Technical data

High-pressure multistage centrifugal pump Zeox-FIRST H 4211-55-2

Project ID Untitled project 2025-03-04 09:37:01.987

Project name
Installation location
Customer pos. No.

Date 2025-03-04

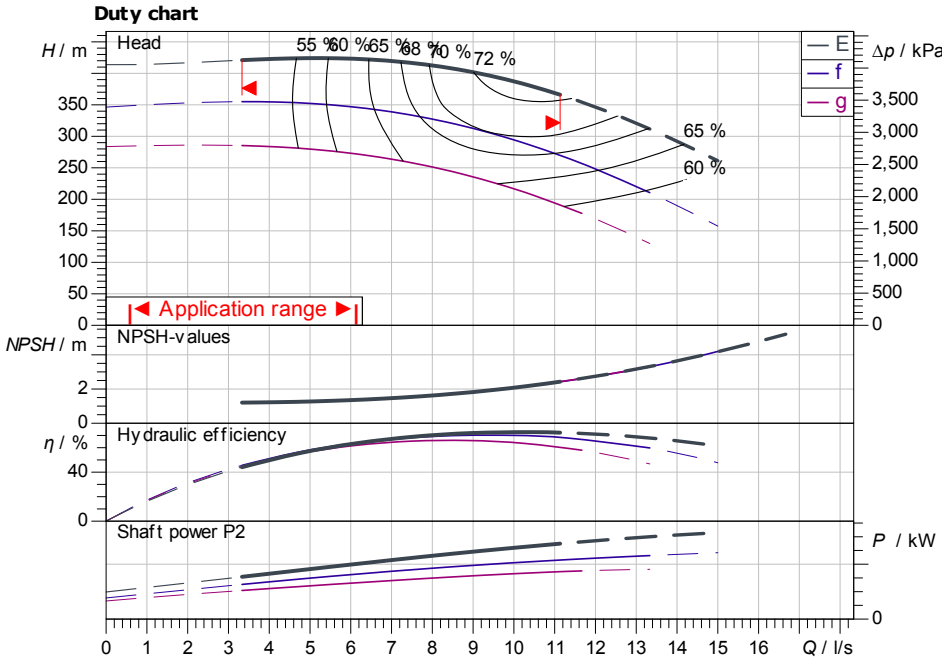

ISO 9906: 2012 3B

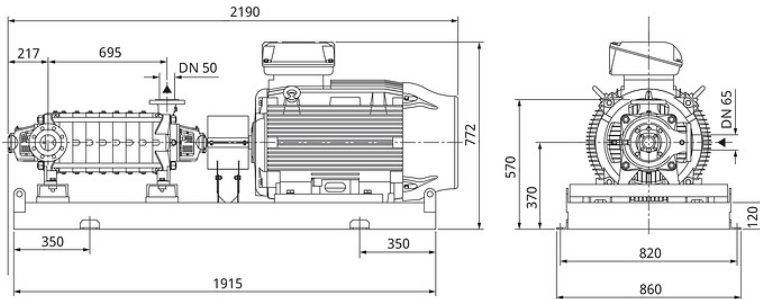

Requested data

Flow
Head
Media Water 100 %
Fluid temperature 20.00 °C
Density 998.30 kg/m³
Kin. viscosity 1.00 mm²/s

Hydraulic data (Duty point)

Flow
Head
Shaft power P2
Hydraulic efficiency
NPSH

Product data

High-pressure multistage centrifugal pump
Zeox-FIRST H 4211-55-2
Max. operating pressure 5,000 kPa
Fluid temperature -5 °C ... +90 °C
Max. ambient temperature 40 °C
Minimum efficiency index (MEI)

Motordata per Motor/Pump

Motor efficiency level IE3
Mains connection 3~ 400 V / 50 Hz
Permitted voltage tolerance +-10 %
Max. speed 2,900 1/min
Rated power P2 55.00 kW
Rated current 95.60 A
Power factor 0.88
Efficiency
50% / 75% / 100% 93.6/94.4/94.4%
Degree of protection IP55
Insulation class F
Motor protection

Fitting dimensions

Pipe connection on the suction side DN 65, PN 25
Pipe connection (pressure side) DN 50, PN 63
Port to Port

Materials

Pump housing EN-GJL-250/EN-GJS-400
Shaft 1.4028
Shaft seal U2BPFG
Impeller EN-GJL-200
Stage chamber material EN-GJS-500-7

Information for order placements

Weight approx.
Item number 4191823

Dimensions mm

Contact
E-mail
Phone

Customer

Contact
E-mail
Phone

Dimensions

High-pressure multistage centrifugal pump
Zeox-FIRST H 4211-55-2

Project ID Untitled project 2025-03-04 09:37:01.987

Project name
Installation location
Customer pos. No.

Date 2025-03-04

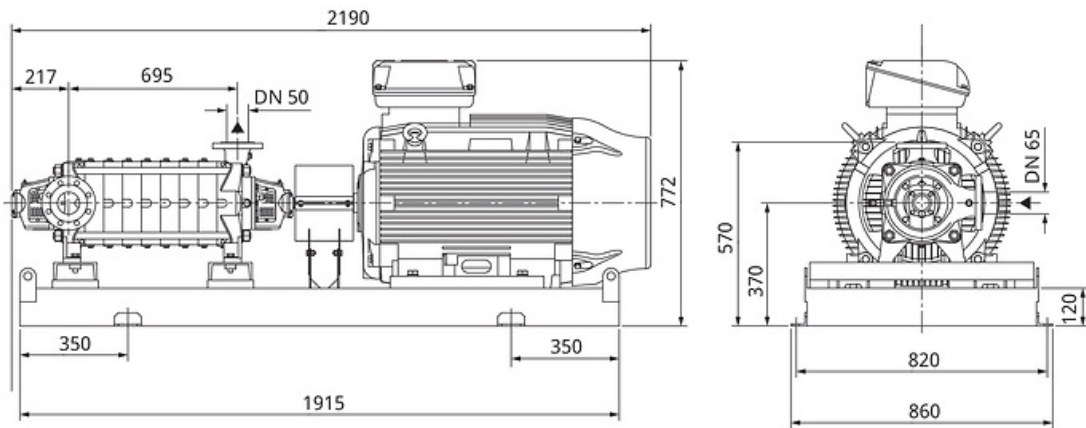

Standard

Suction side DN 65, PN 25/PN 63
Discharge side DN 50, PN 25/PN 63

Dimensions mm

| Name | Value | Name | Value | Name | Value | Name | Value |
|------|-------|------|-------|------|-------|------|-------|
|------|-------|------|-------|------|-------|------|-------|