

Customer

Technical data

High-pressure multistage centrifugal pump Zeox-FIRST H 4204-30-2

Project ID Untitled project 2025-03-04 09:37:01.987

Project name
Installation location
Customer pos. No.

Date 2025-03-04

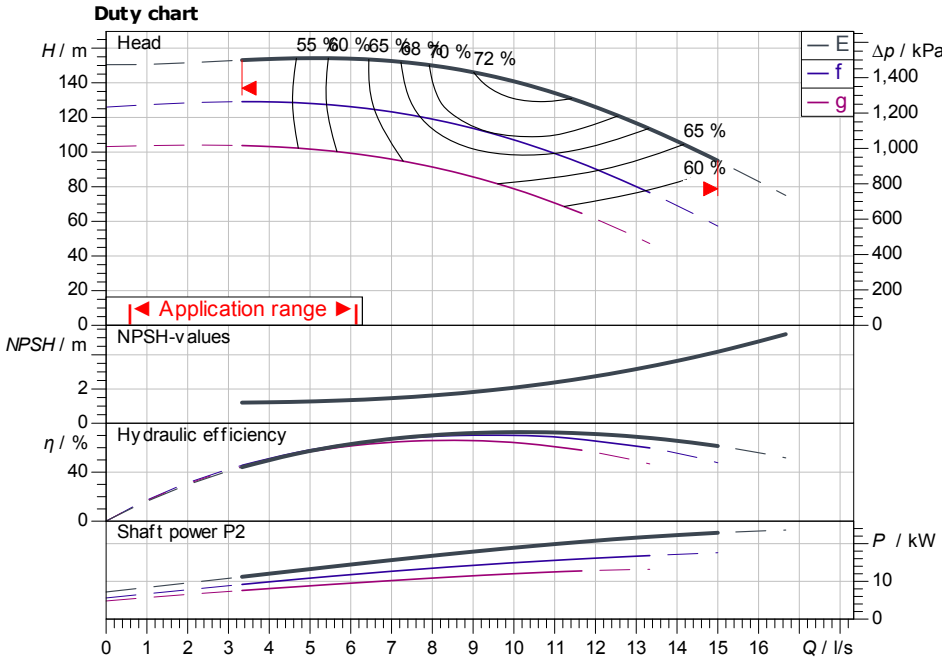

ISO 9906: 2012 3B

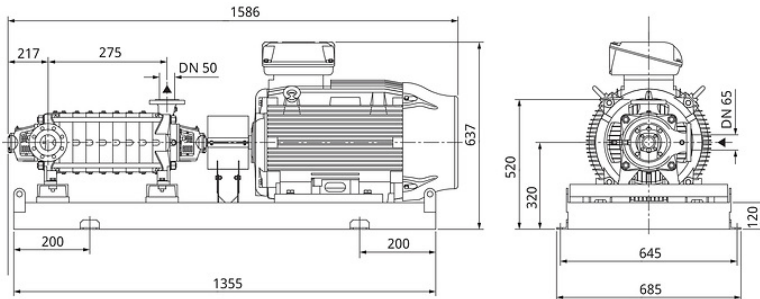

Requested data

Flow	
Head	
Media	Water 100 %
Fluid temperature	20.00 °C
Density	998.30 kg/m ³
Kin. viscosity	1.00 mm ² /s

Hydraulic data (Duty point)

Flow	
Head	
Shaft power P2	
Hydraulic efficiency	
NPSH	

Product data

High-pressure multistage centrifugal pump Zeox-FIRST H 4204-30-2	
Max. operating pressure	5,000 kPa
Fluid temperature	-5 °C ... +90 °C
Max. ambient temperature	40 °C
Minimum efficiency index (MEI)	

Motordata per Motor/Pump

Motor efficiency level	IE3
Mains connection	3~ 400 V / 50 Hz
Permitted voltage tolerance	+ -10 %
Max. speed	2,900 1/min
Rated power P2	30.00 kW
Rated current	54.50 A
Power factor	0.85
Efficiency	
50% / 75% / 100%	92.2/93.2/93.5%
Degree of protection	IP55
Insulation class	F
Motor protection	

Fitting dimensions

Pipe connection on the suction side	DN 65, PN 25
Pipe connection (pressure side)	DN 50, PN 63
Port to Port	

Materials

Pump housing	EN-GJL-250/EN-GJS-400-15
Shaft	1.4028
Shaft seal	U2BPFG
Impeller	EN-GJL-200
Stage chamber material	EN-GJS-500-7

Information for order placements

Weight approx.	
Item number	4191794

Dimensions mm

Contact
E-mail
Phone

Customer

Contact
E-mail
Phone

Dimensions

High-pressure multistage centrifugal pump
Zeox-FIRST H 4204-30-2

Project ID Untitled project 2025-03-04 09:37:01.987

Project name
Installation location
Customer pos. No.

Date 2025-03-04

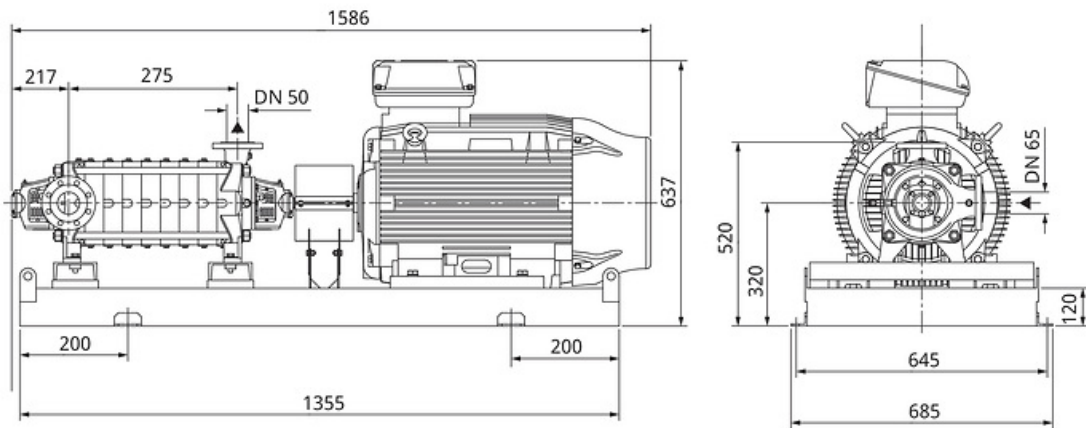

Standard

Suction side DN 65, PN 25/PN 63
Discharge side DN 50, PN 25/PN 63

Dimensions mm

Name	Value	Name	Value	Name	Value	Name	Value
------	-------	------	-------	------	-------	------	-------