

Customer

Technical data

Glanded monobloc pump Atmos BST 40/125-3/2-V1

Project ID: Untitled project 2025-03-01 17:12:44.130

Project name
Installation location
Customer pos. No.

Date: 2025-03-01

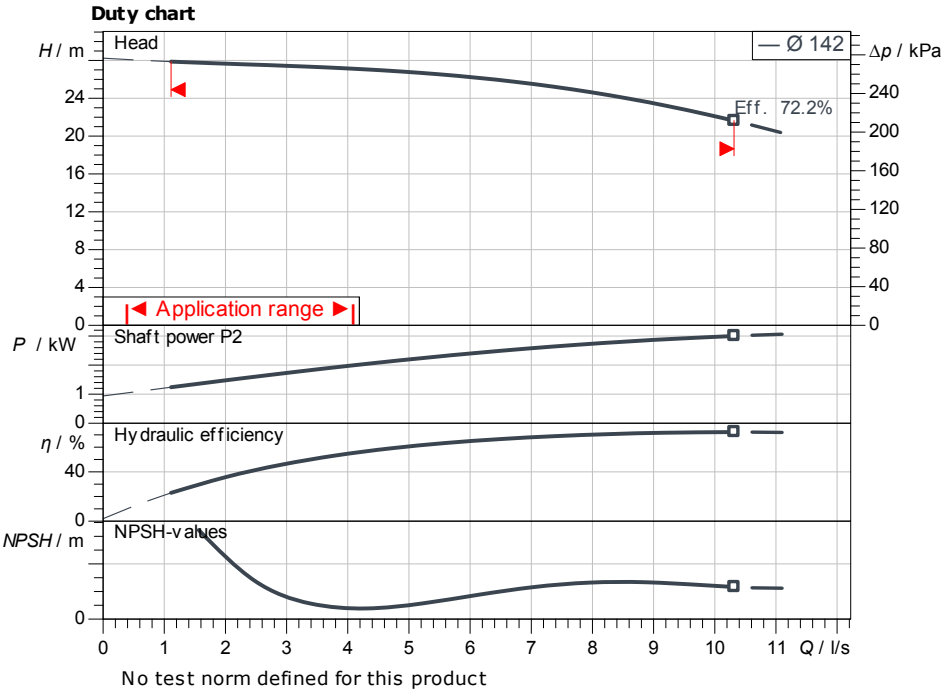

Requested data

Flow
Head
Media: Water 100 %
Fluid temperature: 20.00 °C
Density: 998.30 kg/m³
Kin. viscosity: 1.00 mm²/s

Hydraulic data (Duty point)

Flow
Head
Shaft power P_2
Hydraulic efficiency
NPSH
Impeller size: 142

Product data

Glanded monobloc pump
Atmos BST 40/125-3/2-V1
Max. operating pressure: 1,000 kPa
Fluid temperature: -20 °C ... +120 °C
Max. ambient temperature: 50 °C
Minimum efficiency index (MEI) ≥ 0.4

Motordata per Motor/Pump

Motor efficiency level: IE3
Mains connection: 3~ 400 V / 50 Hz
Permitted voltage tolerance: +6 %
Max. speed: 2,900 1/min
Rated power P_2 : 3.00 kW
Rated current: 5.70 A
Power factor: 0.87
Efficiency: 50% / 75% / 100% // %
Degree of protection: IP55
Insulation class: F
Motor protection

Fitting dimensions

Pipe connection on the suction side: DN 65, PN 16
Pipe connection (pressure side): DN 40, PN 16
Port to Port

Materials

Pump housing: 1.4301
Impeller: 1.4301
Shaft: 1.4301
Shaft seal: B3Q1EF

Information for order placements

Weight approx.
Item number: 9187061

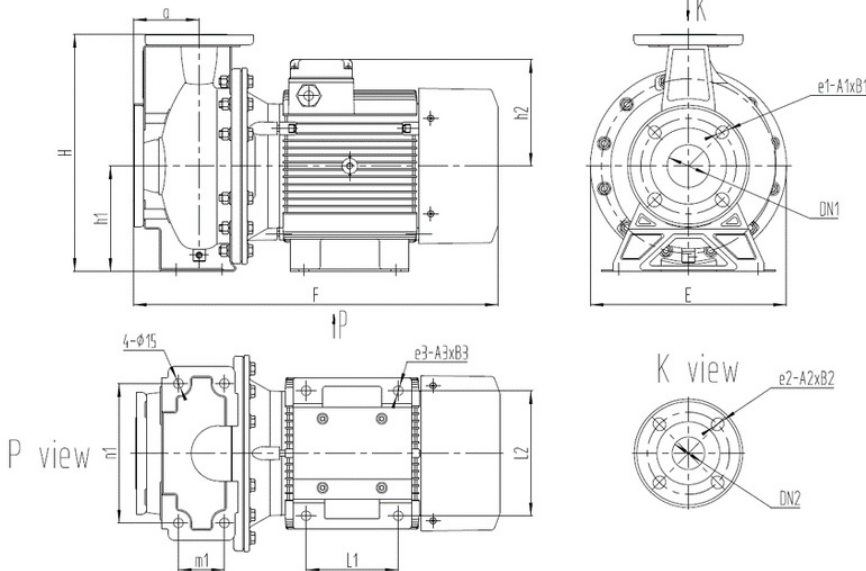

Dimensions

mm

A	80	B2	20	E	256	L1	100
A1	18	B3	18	F	456	L2	160
A2	18	dL	18	H	292	M1	70
A3	12	DN1	DN 65, P	H1	132	n1	190
B1	20	DN2	DN 40, P	H2	112	$\varnothing k$	145



Contact
E-mail
Phone

Customer

Contact
E-mail
Phone

Hydraulic data

Glanded monobloc pump
Atmos BST 40/125-3/2-V1

Project ID: Untitled project 2025-03-01 17:12:44.130

Project name
Installation location
Customer pos. No.

Date: 2025-03-01

Operating data

Rotational speed 2908 1/min	Frequency 50 Hz	Duty point Q =	H =	Suction port DN 65	Discharge port DN 40
---------------------------------------	---------------------------	--------------------------	------------	------------------------------	--------------------------------

Power data referred to: Water; 20°C; 998.3kg/m³; 1.005mm²/s ±10 % tolerance with linear U/f frequency control

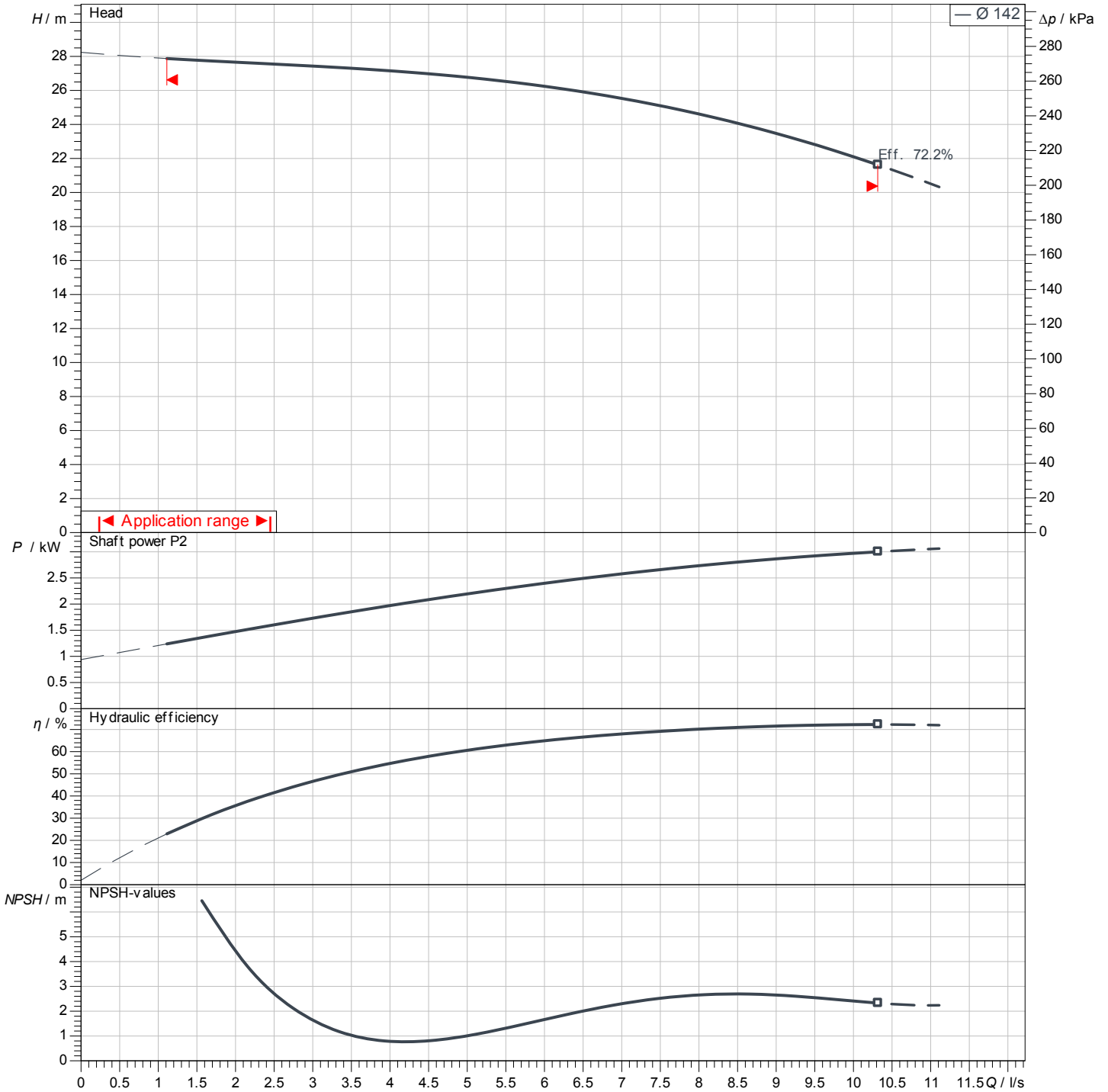

No test norm defined for this product

Contact
E-mail
Phone

Customer

Contact
E-mail
Phone

Dimensions

Glanded monobloc pump
Atmos BST 40/125-3/2-V1

Project ID Untitled project 2025-03-01 17:12:44.130

Project name
Installation location
Customer pos. No.

Date 2025-03-01

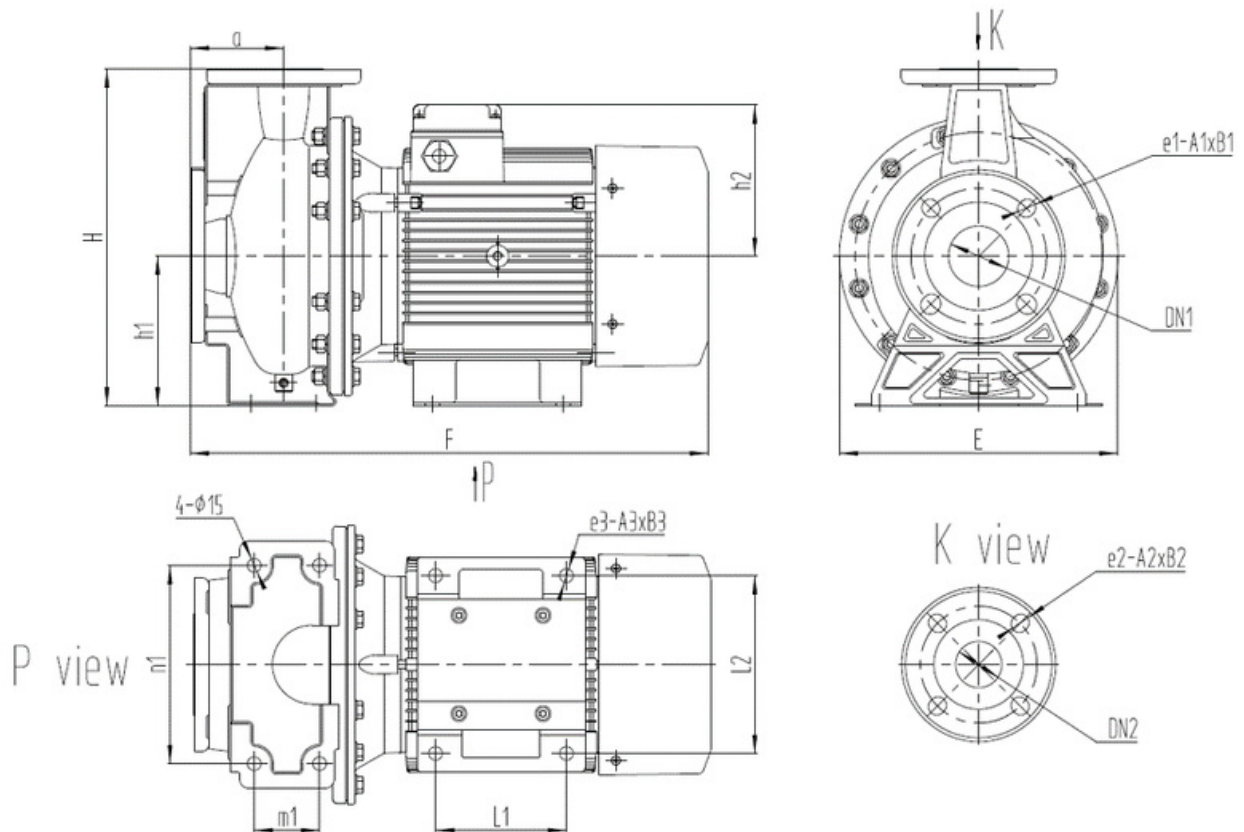

Standard

Suction side DN 65, PN 16
Discharge side DN 40, PN 16

Dimensions mm

Name	Value	Name	Value	Name	Value	Name	Value
A	80	dL	18	H2	112	Ø D	185
A1	18	DN1	DN 65, PN 16	L1	100		
A2	18	DN2	DN 40, PN 16	L2	160		
A3	12	E	256	M1	70		
B1	20	F	456	n1	190		
B2	20	H	292	Ø k	145		
B3	18	H1	132	Ø d	108		