

**Customer**

## Technical data

Glanded standard pump  
Atmos GIGA-N 50/315-75/2-IE4

Project ID: Untitled project 2025-03-03 06:26:03.775

Project name  
Installation location  
Customer pos. No.

Date: 2025-03-03

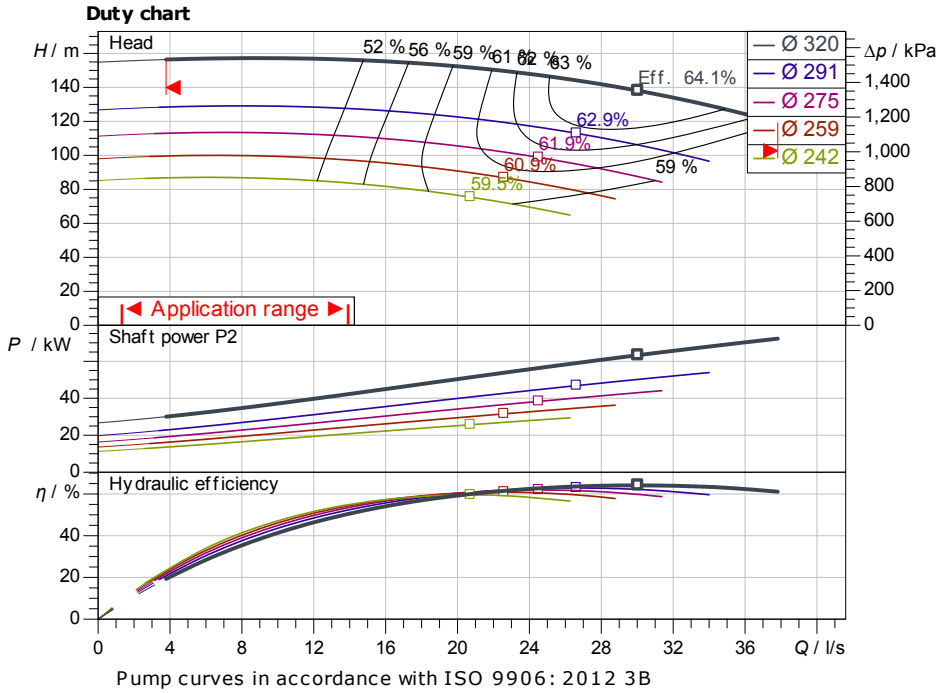

**Requested data**

Flow  
Head  
Media: Water 100 %  
Fluid temperature: 20.00 °C  
Density: 998.30 kg/m<sup>3</sup>  
Kin. viscosity: 1.00 mm<sup>2</sup>/s

**Hydraulic data (Duty point)**

Flow  
Head  
Shaft power P2  
Hydraulic efficiency  
NPSH  
Impeller size: 320

**Product data**

Glanded standard pump  
Atmos GIGA-N 50/315-75/2-IE4  
Max. operating pressure: 1,600 kPa  
Fluid temperature: -20 °C ... +140 °C  
Max. ambient temperature: 40 °C  
Minimum efficiency index (MEI): ≥ 0.4

**Motordata per Motor/Pump**

Motor efficiency level: IE4  
Mains connection: 3~ 400 V / 50 Hz  
Permitted voltage tolerance: +10 %  
Max. speed: 2,980 1/min  
Rated power P2: 75.00 kW  
Rated current: 125.00 A  
Power factor: 0.9  
Efficiency: 50% / 75% / 100% → 95.1/96/96.3%  
Degree of protection: IP55  
Insulation class: F  
Motor protection: PTC integrated

**Fitting dimensions**

Pipe connection on the suction side: DN 65, PN 16  
Pipe connection (pressure side): DN 50, PN 16  
Port to Port

**Materials**

Pump housing: 5.1301/EN-GJL-250  
Impeller: EN-GJL-200  
Lantern: 5.1301/EN-GJL-250  
Shaft: 1.4021  
Shaft seal: AQ1EGG

**Information for order placements**

Weight approx.: 1249 kg  
Item number: 6096200

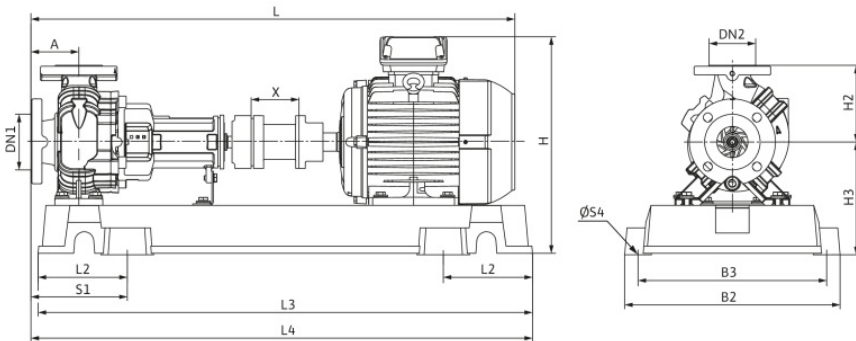

**Dimensions**

mm

A	125	H	875	L3	1,840
B2	730	H2	280	L4	1,870
B3	670	H3	403	S1	350
DN1	DN 65, P	L	1,766	S4	29
DN2	DN 50, P	L2	320	X	100



Contact  
E-mail  
Phone

Customer

Contact  
E-mail  
Phone

# Hydraulic data

Glanded standard pump  
Atmos GIGA-N 50/315-75/2-IE4

Project ID: Untitled project 2025-03-03 06:26:03.775

Project name  
Installation location  
Customer pos. No.

Date: 2025-03-03

## Operating data

Rotational speed <b>2975 1/min</b>	Frequency <b>50 Hz</b>	Duty point <b>Q =</b>	<b>H =</b>	Suction port <b>DN 65</b>	Discharge port <b>DN 50</b>
---------------------------------------	---------------------------	--------------------------	------------	------------------------------	--------------------------------

Power data referred to: Water; 20°C; 998.3kg/m³; 1.005mm²/s ±10 % tolerance with linear U/f frequency control

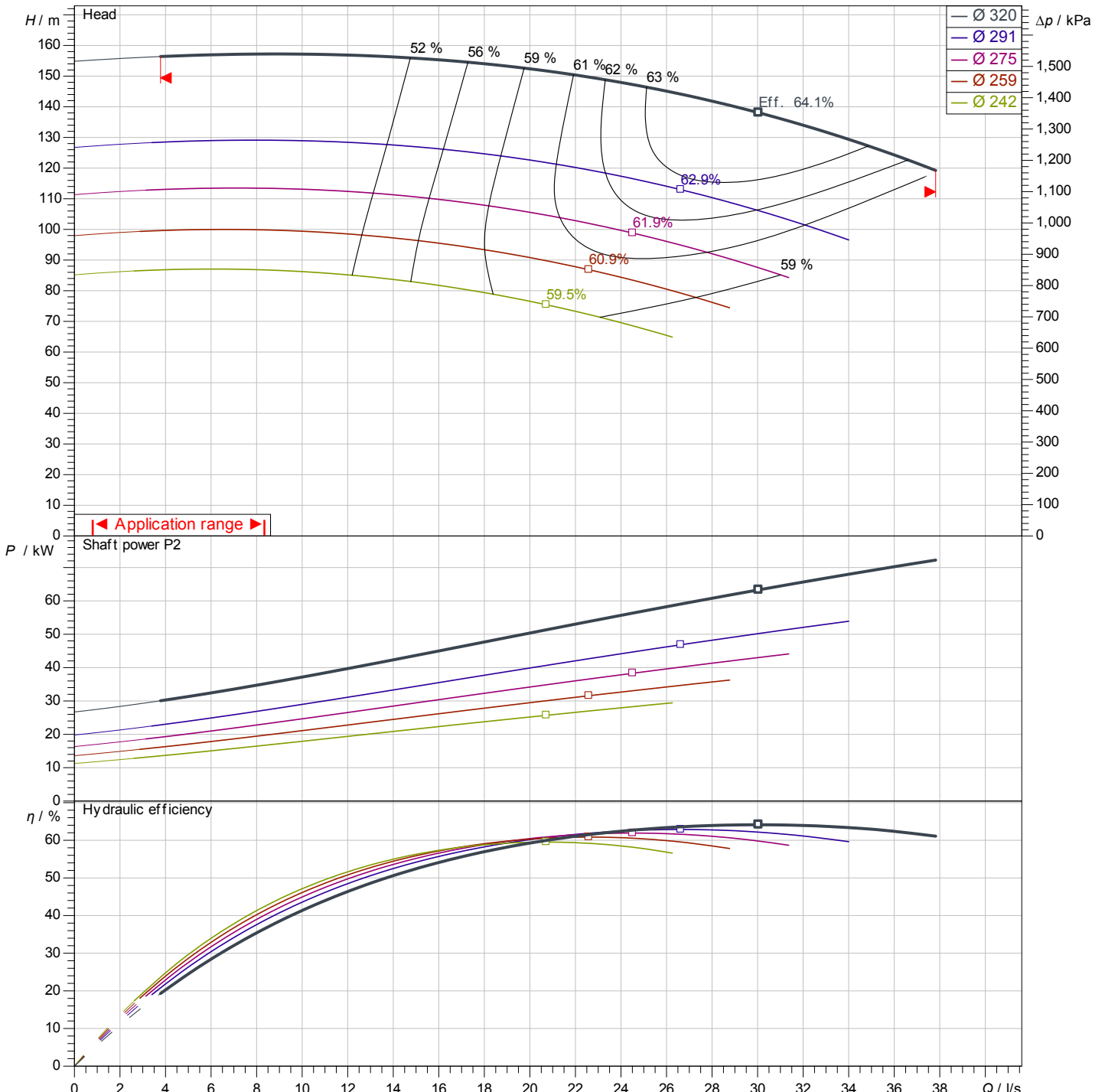

Pump curves in accordance with ISO 9906: 2012 3B

Contact  
E-mail  
Phone

**Customer**

Contact  
E-mail  
Phone

## Dimensions

Glanded standard pump  
Atmos GIGA-N 50/315-75/2-IE4

Project ID                      Untitled project 2025-03-03 06:26:03.775

Project name  
Installation location  
Customer pos. No.

Date                      2025-03-03



**Coupling with spacer**

Suction side                      DN 65, PN 16  
Discharge side                      DN 50, PN 16

**Dimensions**                      mm

Name	Value	Name	Value	Name	Value	Name	Value
A	125	H3	403	X	100		
B2	730	L	1,766				
B3	670	L2	320				
DN1	DN 65, PN 16	L3	1,840				
DN2	DN 50, PN 16	L4	1,870				
H	875	S1	350				
H2	280	S4	29				