

**Customer**

## Technical data

### Glanded monobloc pump Atmos BST 25/160-1.1/2-V4

Project ID                      Untitled project 2025-03-01 17:12:44.130

Project name  
Installation location  
Customer pos. No.

Date                      2025-03-01

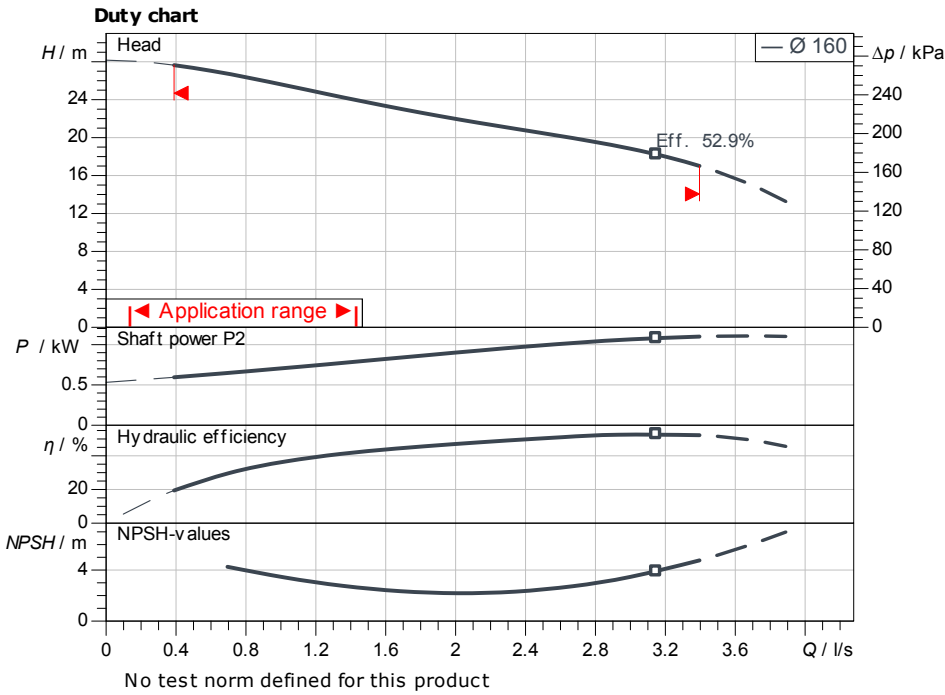

**Requested data**

Flow	
Head	
Media	Water 100 %
Fluid temperature	20.00 °C
Density	998.30 kg/m <sup>3</sup>
Kin. viscosity	1.00 mm <sup>2</sup> /s

**Hydraulic data (Duty point)**

Flow	
Head	
Shaft power P2	
Hydraulic efficiency	
NPSH	
Impeller size	160

**Product data**

Glanded monobloc pump	
Atmos BST 25/160-1.1/2-V4	
Max. operating pressure	1,000 kPa
Fluid temperature	-20 °C ... +120 °C
Max. ambient temperature	50 °C
Minimum efficiency index (MEI)	≥ 0.4

**Motordata per Motor/Pump**

Motor efficiency level	IE2
Mains connection	1~ 230 V / 50 Hz
Permitted voltage tolerance	+6 %
Max. speed	2,900 1/min
Rated power P2	1.10 kW
Rated current	6.70 A
Power factor	0.95
Efficiency	
50% / 75% / 100%	//%
Degree of protection	IP55
Insulation class	F
Motor protection	PTC

**Fitting dimensions**

Pipe connection on the suction side	G 1 1/4, PN 10
Pipe connection (pressure side)	G 1, PN 10
Port to Port	

**Materials**

Pump housing	1.4301
Impeller	1.4301
Shaft	1.4301
Shaft seal	B9Q1EF

**Information for order placements**

Weight approx.	
Item number	9187037

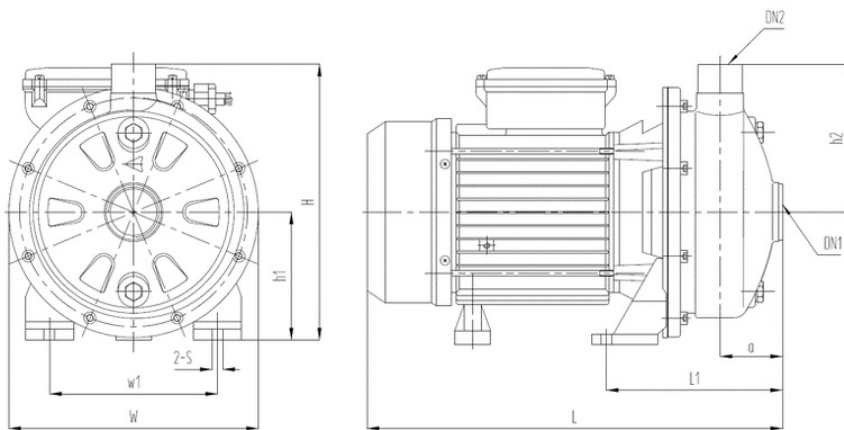

Dimensions		mm	
A	53	H2	121
DN1	G 1 1/4, PN	L	347
DN2	G 1, PN 1	L1	148
H	227	W	208
H1	106	W1	120



Contact  
E-mail  
Phone

**Customer**

Contact  
E-mail  
Phone

### Hydraulic data

Glanded monobloc pump  
Atmos BST 25/160-1.1/2-V4

Project ID                      Untitled project 2025-03-01 17:12:44.130

Project name  
Installation location  
Customer pos. No.

Date                      2025-03-01

### Operating data

Rotational speed <b>2844 1/min</b>	Frequency <b>50 Hz</b>	Duty point <b>Q =</b>	<b>H =</b>	Suction port <b>G 1 1/4</b>	Discharge port <b>G 1</b>
---------------------------------------	---------------------------	--------------------------	------------	--------------------------------	------------------------------

Power data referred to:                      Water; 20°C; 998.3kg/m<sup>3</sup>; 1.005mm<sup>2</sup>/s                      ±10 % tolerance with linear U/f frequency control

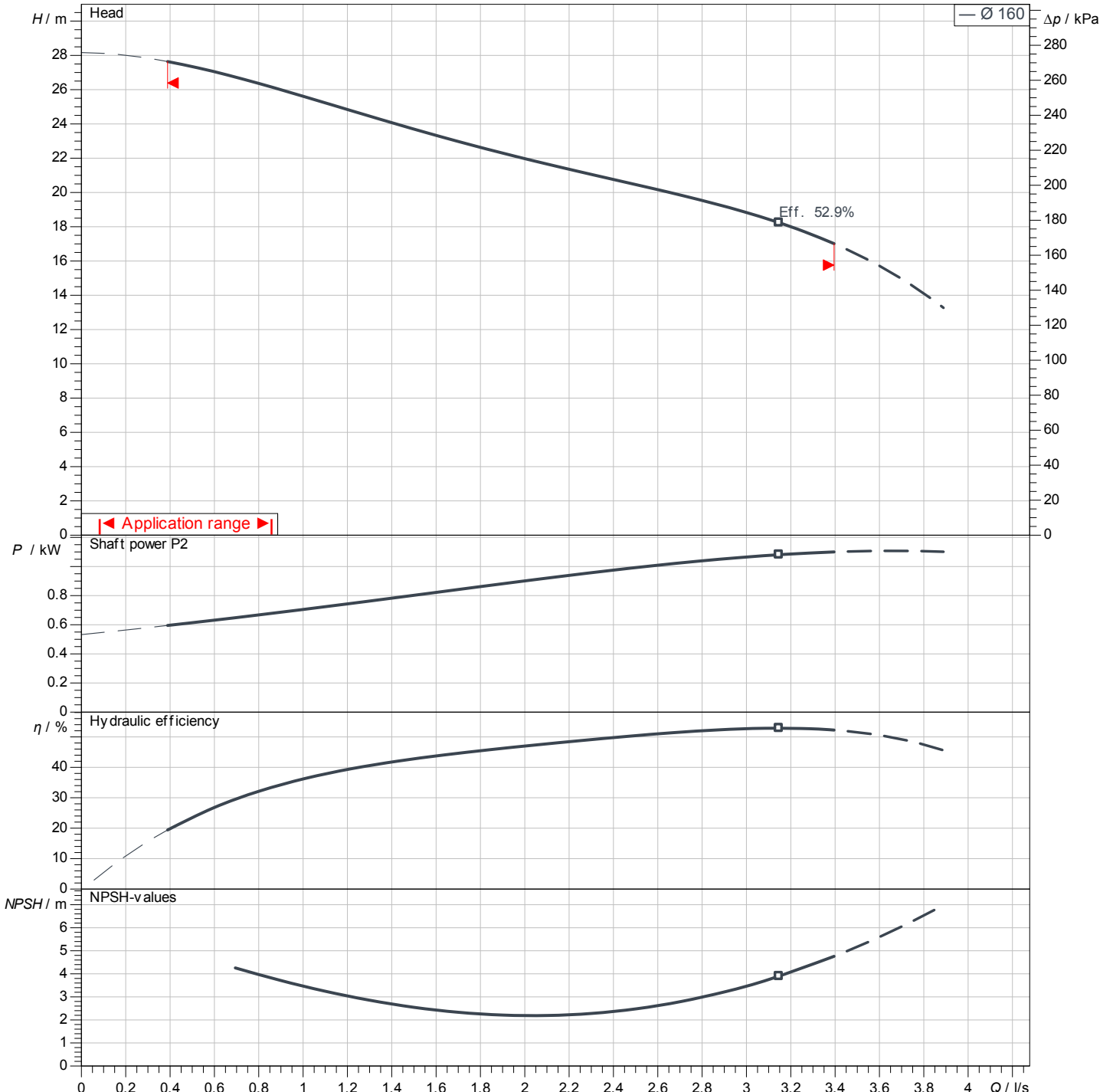

No test norm defined for this product

Contact  
E-mail  
Phone

**Customer**

Contact  
E-mail  
Phone

## Dimensions

Glanded monobloc pump  
Atmos BST 25/160-1.1/2-V4

Project ID                      Untitled project 2025-03-01 17:12:44.130

Project name  
Installation location  
Customer pos. No.

Date                      2025-03-01

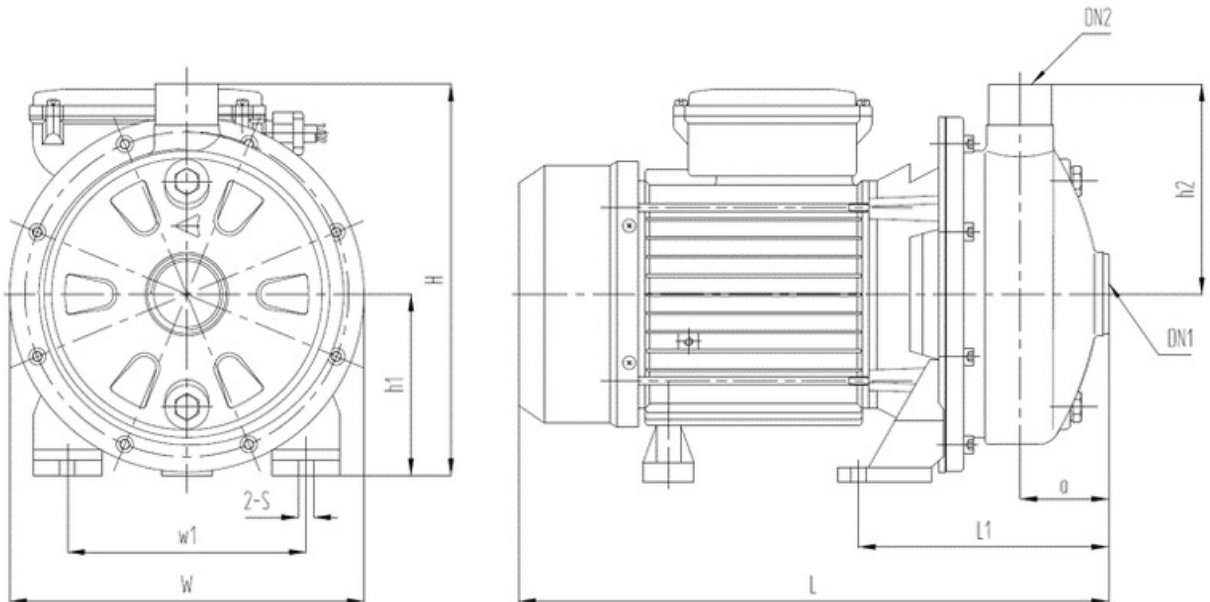

**Standard**

Suction side                      G 1 ¼, PN 10  
Discharge side                      G 1, PN 10

**Dimensions**                      mm

Name	Value	Name	Value	Name	Value	Name	Value
A	53	L1	148				
DN1	G 1 ¼, PN 10	W	208				
DN2	G 1, PN 10	W1	120				
H	227						
H1	106						
H2	121						
L	347						