

Customer

Technical data

High-pressure multistage centrifugal pump Medana CH1-L.403-1/E/E/10T

Project ID Untitled project 2025-03-03 23:00:00.495

Project name
Installation location
Customer pos. No.

Date 2025-03-03

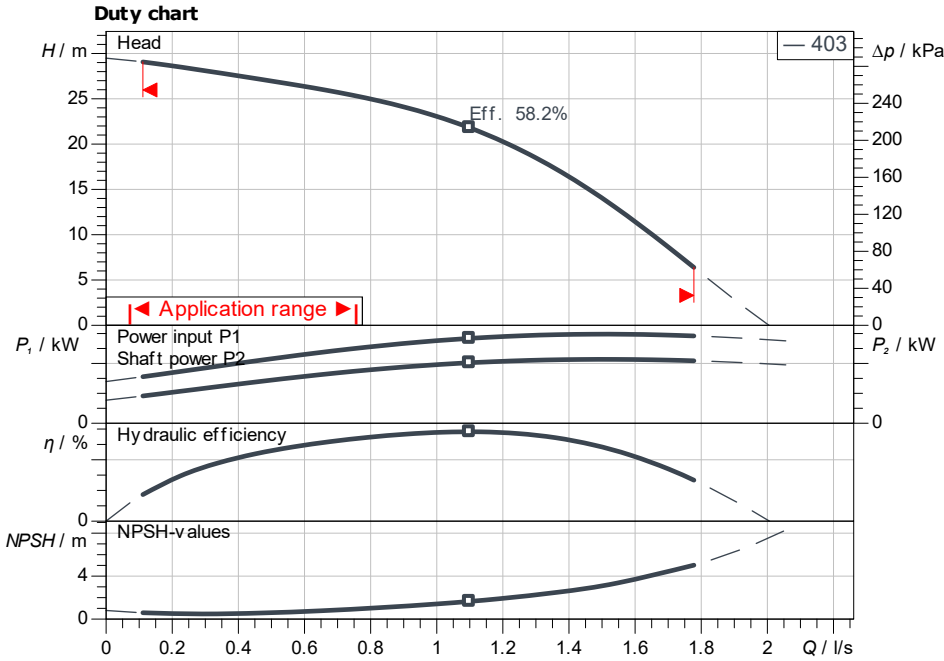

Requested data

Flow	
Head	
Media	Water 100 %
Fluid temperature	20.00 °C
Density	998.30 kg/m ³
Kin. viscosity	1.00 mm ² /s

Hydraulic data (Duty point)

Flow
Head

Product data

High-pressure multistage centrifugal pump Medana CH1-L.403-1/E/E/10T	
Max. operating pressure	1,000 kPa
Inlet pressure max.	600 kPa
Fluid temperature	-20 °C ... +120 °C
Max. ambient temperature	50 °C

Motordata per Motor/Pump

Motor efficiency class	IE2
Mains connection	3~ 400 V / 50 Hz
Permitted voltage tolerance	+ -10 %
Max. speed	2,900 1/min
Rated power P2	0.37 kW
Rated current	1.10 A
0	
Degree of protection	IP55
Insulation class	F
Motor protection	No

Fitting dimensions

Pipe connection on the suction side	Rp 1, PN 10
Pipe connection (pressure side)	Rp 1, PN 10

Materials

Pump housing	1.4301
Impeller	1.4301
Shaft	1.4301
Shaft seal	BQ7EGG
Gasket material	EPDM
Stage chamber material	1.4301

Information for order placements

Weight approx.	9.4 kg
Item number	4231477

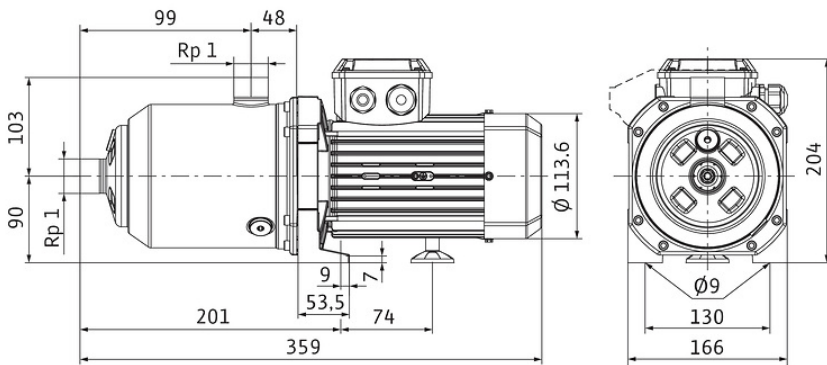

Dimensions mm