

Customer

Technical data

Glanded standard pump
Atmos GIGA-N 50/160-2.2/4/6

Project ID: Untitled project 2025-03-05 00:23:19.113

Project name
Installation location
Customer pos. No.

Date: 2025-03-05

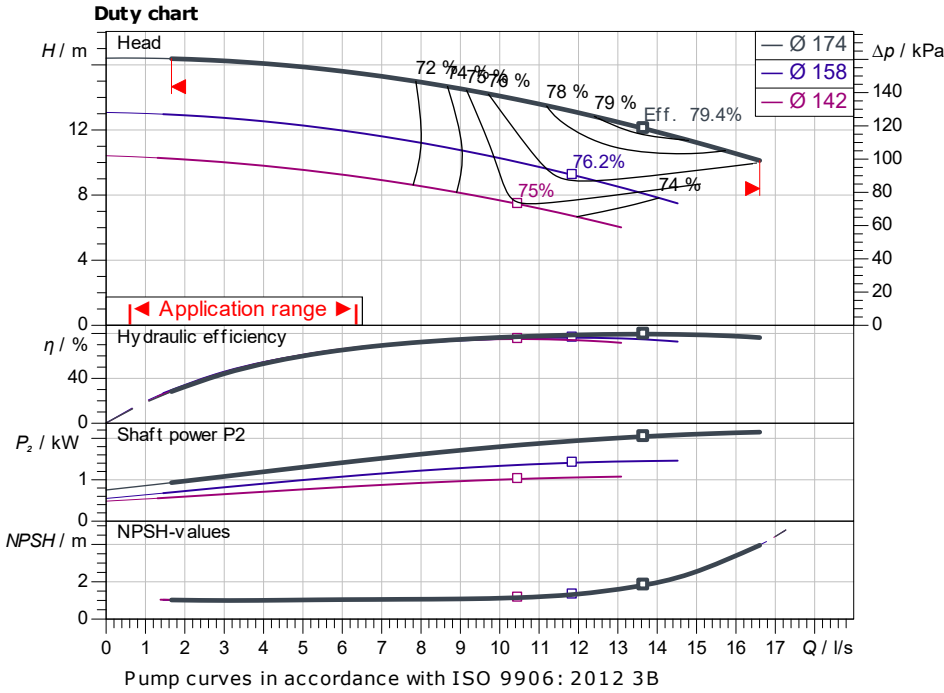

Requested data

Flow
Head
Media: Water 100 %
Fluid temperature: 20.00 °C
Density: 998.30 kg/m³
Kin. viscosity: 1.00 mm²/s

Hydraulic data (Duty point)

Flow
Head
Shaft power P2
Hydraulic efficiency
NPSH
Impeller size: 174

Product data

Glanded standard pump
Atmos GIGA-N 50/160-2.2/4/6
Max. operating pressure: 1,600 kPa
Fluid temperature: -20 °C ... +140 °C
Max. ambient temperature: 40 °C
Minimum efficiency index (MEI): ≥ 0.4

Motordata per Motor/Pump

Motor efficiency level: IE3
Mains connection: 3~ 380 V / 60 Hz
Permitted voltage tolerance: +10 %
Max. speed: 1,760 1/min
Rated power P2: 2.20 kW
Rated current: 4.90 A
Power factor: 0.77
Efficiency: 50% / 75% / 100% → 87.2/89.5/89.5%
Degree of protection: IP55
Insulation class: F
Motor protection: No

Fitting dimensions

Pipe connection on the suction side: DN 65, PN 16
Pipe connection (pressure side): DN 50, PN 16
Port to Port

Materials

Pump housing: 5.1301/EN-GJL-250
Impeller: EN-GJL-200
Lantern: 5.1301/EN-GJL-250
Shaft: 1.4021
Shaft seal: AQ1EGG

Information for order placements

Weight approx.: 131 kg
Item number

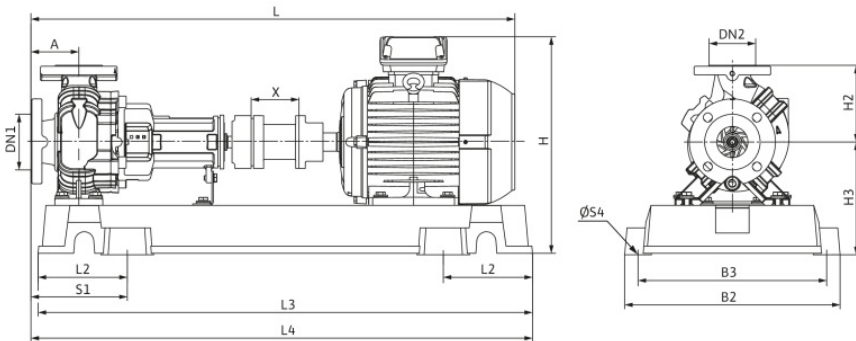

Dimensions

mm

A	100	H	410	L3	930
B2	390	H2	180	L4	955
B3	350	H3	243	S1	190
DN1	DN 65, P	L	936	S4	19
DN2	DN 50, P	L2	165	X	100



Contact
E-mail
Phone

Customer

Contact
E-mail
Phone

Hydraulic data

Glanded standard pump
Atmos GIGA-N 50/160-2.2/4/6

Project ID: Untitled project 2025-03-05 00:23:19.113

Project name
Installation location
Customer pos. No.

Date: 2025-03-05

Operating data

Rotational speed 1750 1/min	Frequency 60 Hz	Duty point Q =	H =	Suction port DN 65	Discharge port DN 50
---------------------------------------	---------------------------	--------------------------	------------	------------------------------	--------------------------------

Power data referred to: Water; 20°C; 998.3kg/m³; 1.005mm²/s ±10 % tolerance with linear U/f frequency control

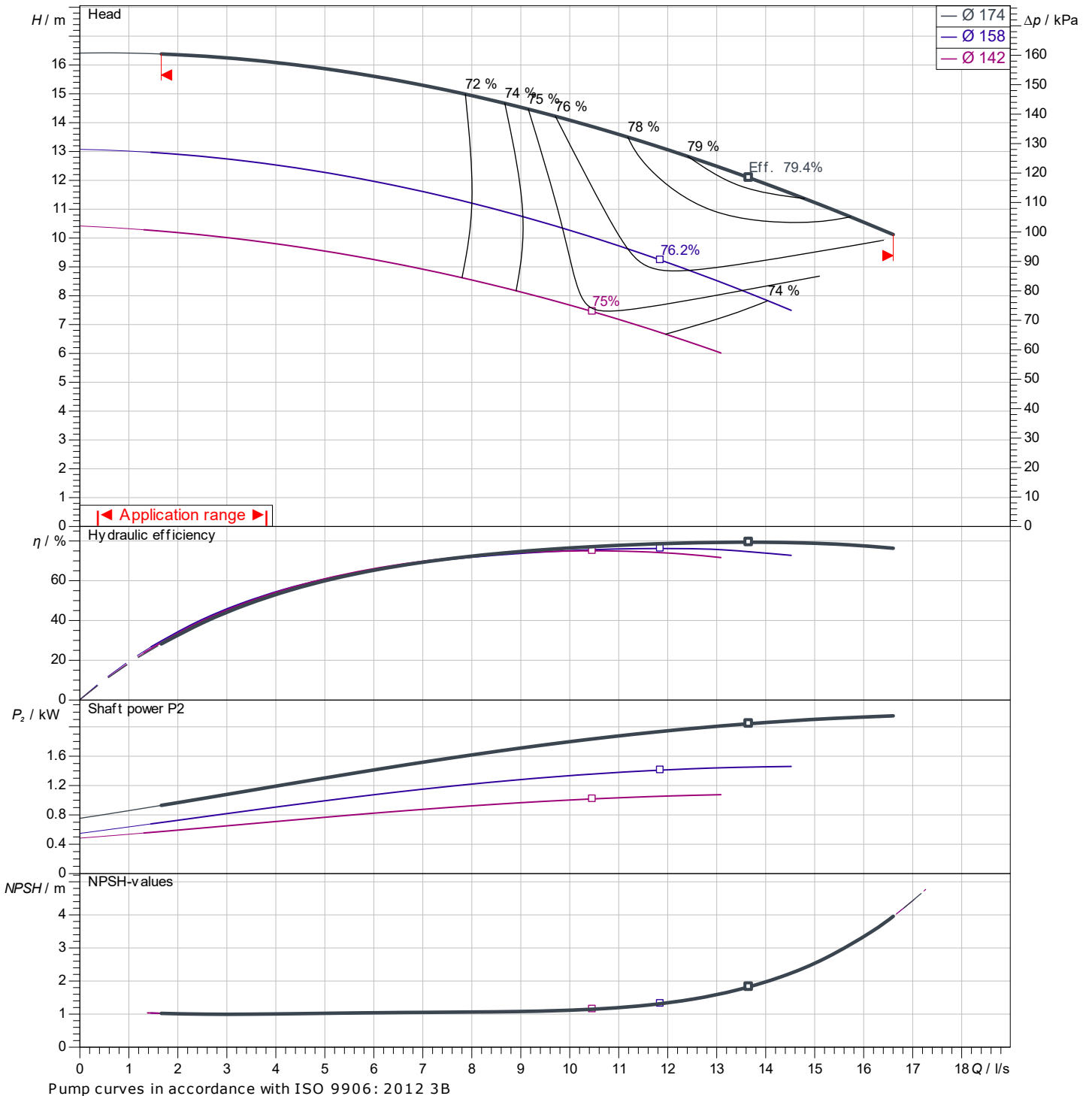

Pump curves in accordance with ISO 9906: 2012 3B

Contact
E-mail
Phone

Customer

Contact
E-mail
Phone

Dimensions

Glanded standard pump
Atmos GIGA-N 50/160-2.2/4/6

Project ID Untitled project 2025-03-05 00:23:19.113

Project name
Installation location
Customer pos. No.

Date 2025-03-05



Coupling with spacer

Suction side DN 65, PN 16
Discharge side DN 50, PN 16

Dimensions mm

Name	Value	Name	Value	Name	Value	Name	Value
A	100	H3	243	X	100		
B2	390	L	936				
B3	350	L2	165				
DN1	DN 65, PN 16	L3	930				
DN2	DN 50, PN 16	L4	955				
H	410	S1	190				
H2	180	S4	19				