

Customer

Technical data

Glanded standard pump Atmos GIGA-N 80/250-132/2/6

Project ID: Untitled project 2025-03-05 00:23:19.113

Project name
Installation location
Customer pos. No.

Date: 2025-03-05

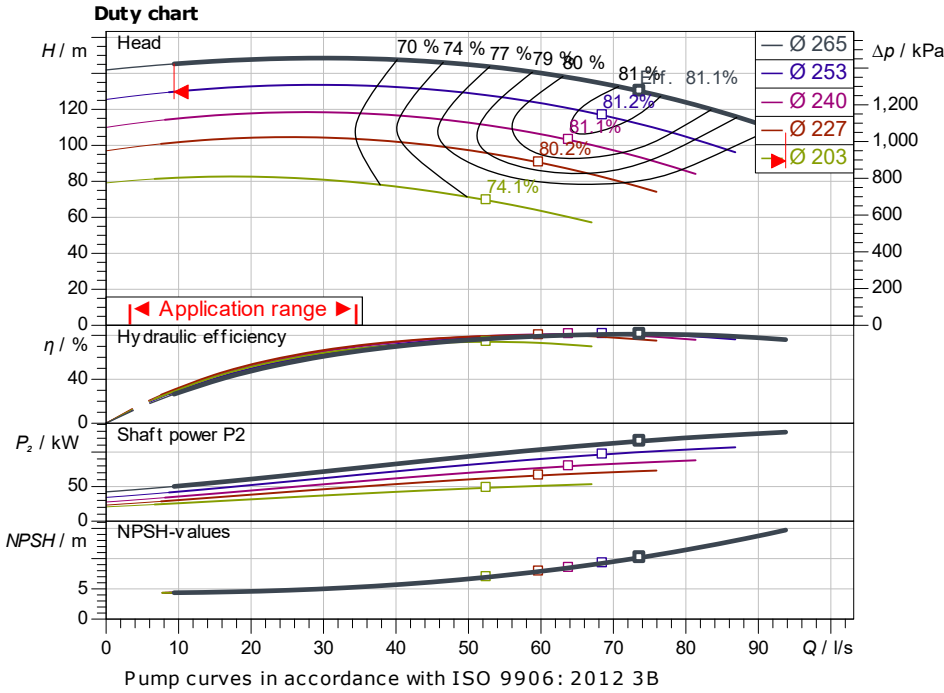

Requested data

Flow
Head
Media: Water 100 %
Fluid temperature: 20.00 °C
Density: 998.30 kg/m³
Kin. viscosity: 1.00 mm²/s

Hydraulic data (Duty point)

Flow
Head
Shaft power P2
Hydraulic efficiency
NPSH
Impeller size: 265

Product data

Glanded standard pump
Atmos GIGA-N 80/250-132/2/6
Max. operating pressure: 1,600 kPa
Fluid temperature: -20 °C ... +140 °C
Max. ambient temperature: 40 °C
Minimum efficiency index (MEI) ≥ 0.4

Motordata per Motor/Pump

Motor efficiency level: IE3
Mains connection: 3~ 380 V / 60 Hz
Permitted voltage tolerance: +10 %
Max. speed: 3,575 1/min
Rated power P2: 132.00 kW
Rated current: 233.60 A
Power factor: 0.9
Efficiency: 50% / 75% / 100% → 93.9/95.4/95.4%
Degree of protection: IP55
Insulation class: F
Motor protection: No

Fitting dimensions

Pipe connection on the suction side: DN 100, PN 16
Pipe connection (pressure side): DN 80, PN 16
Port to Port

Materials

Pump housing: 5.1301/EN-GJL-250
Impeller: EN-GJL-200
Lantern: 5.1301/EN-GJL-250
Shaft: 1.4021
Shaft seal: AQ1EGG

Information for order placements

Weight approx.: 901.9 kg
Item number

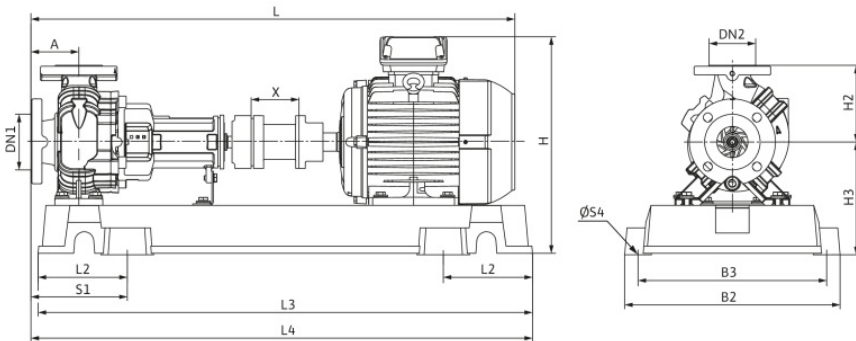

Dimensions

mm

A	125	H	851	L3	1,840
B2	730	H2	280	L4	1,855
B3	670	H3	400	S1	355
DN1	DN 100, L	L	1,806	S4	29
DN2	DN 80, P	L2	120	X	140



Contact
E-mail
Phone

Customer

Contact
E-mail
Phone

Hydraulic data

Glanded standard pump
Atmos GIGA-N 80/250-132/2/6

Project ID: Untitled project 2025-03-05 00:23:19.113

Project name
Installation location
Customer pos. No.

Date: 2025-03-05

Operating data

Rotational speed 3480 1/min	Frequency 60 Hz	Duty point Q =	H =	Suction port DN 100	Discharge port DN 80
---------------------------------------	---------------------------	--------------------------	------------	-------------------------------	--------------------------------

Power data referred to: Water; 20°C; 998.3kg/m³; 1.005mm²/s ±10 % tolerance with linear U/f frequency control

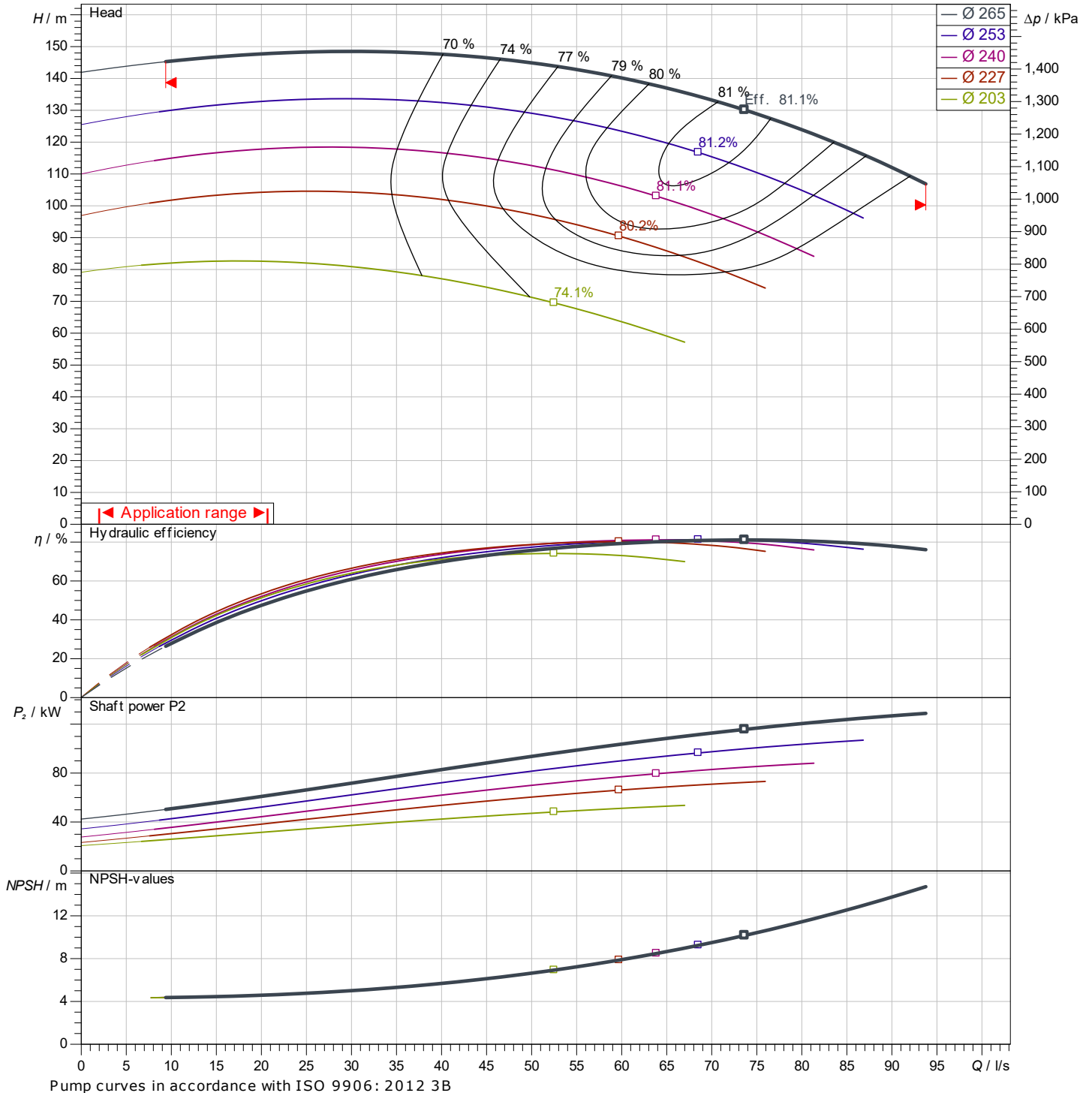

Pump curves in accordance with ISO 9906: 2012 3B

Contact
E-mail
Phone

Customer

Contact
E-mail
Phone

Dimensions

Glanded standard pump
Atmos GIGA-N 80/250-132/2/6

Project ID Untitled project 2025-03-05 00:23:19.113

Project name
Installation location
Customer pos. No.

Date 2025-03-05



Coupling with spacer

Suction side DN 100, PN 16
Discharge side DN 80, PN 16

Dimensions mm

Name	Value	Name	Value	Name	Value	Name	Value
A	125	H3	400	X	140		
B2	730	L	1,806				
B3	670	L2	120				
DN1	DN 100, PN 16	L3	1,840				
DN2	DN 80, PN 16	L4	1,855				
H	851	S1	355				
H2	280	S4	29				