

**Customer**

## Technical data

### Glanded standard pump Atmos GIGA-N 40/200-22/2/6

Project ID: Untitled project 2025-03-05 00:23:19.113

Project name  
Installation location  
Customer pos. No.

Date: 2025-03-05

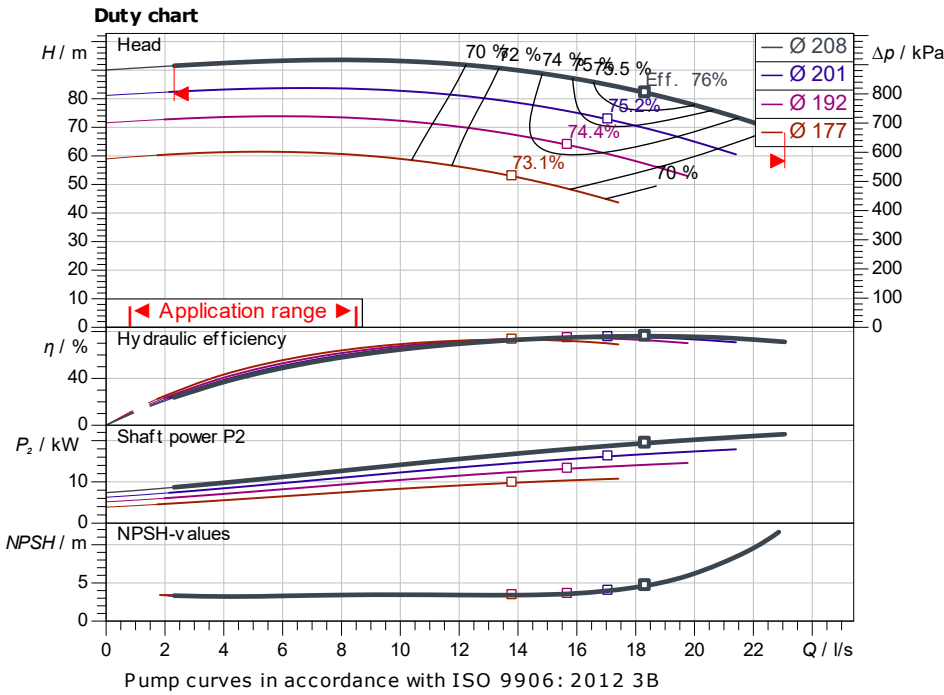

#### Requested data

Flow  
Head  
Media: Water 100 %  
Fluid temperature: 20.00 °C  
Density: 998.30 kg/m<sup>3</sup>  
Kin. viscosity: 1.00 mm<sup>2</sup>/s

#### Hydraulic data (Duty point)

Flow  
Head  
Shaft power P2  
Hydraulic efficiency  
NPSH  
Impeller size: 208

#### Product data

Glanded standard pump  
Atmos GIGA-N 40/200-22/2/6  
Max. operating pressure: 1,600 kPa  
Fluid temperature: -20 °C ... +140 °C  
Max. ambient temperature: 40 °C  
Minimum efficiency index (MEI): ≥ 0.4

#### Motordata per Motor/Pump

Motor efficiency level: IE3  
Mains connection: 3~ 380 V / 60 Hz  
Permitted voltage tolerance: +10 %  
Max. speed: 3,560 1/min  
Rated power P2: 22.00 kW  
Rated current: 41.00 A  
Power factor: 0.89  
Efficiency: 50% / 75% / 100% → 91.2/91.7/91.7%  
Degree of protection: IP55  
Insulation class: F  
Motor protection: No

#### Fitting dimensions

Pipe connection on the suction side: DN 65, PN 16  
Pipe connection (pressure side): DN 40, PN 16  
Port to Port

#### Materials

Pump housing: 5.1301, EN-GJL-250 c  
Impeller: EN-GJL-200  
Lantern: 5.1301/EN-GJL-250  
Shaft: 1.4021  
Shaft seal: AQ1EGG

#### Information for order placements

Weight approx.: 329 kg  
Item number

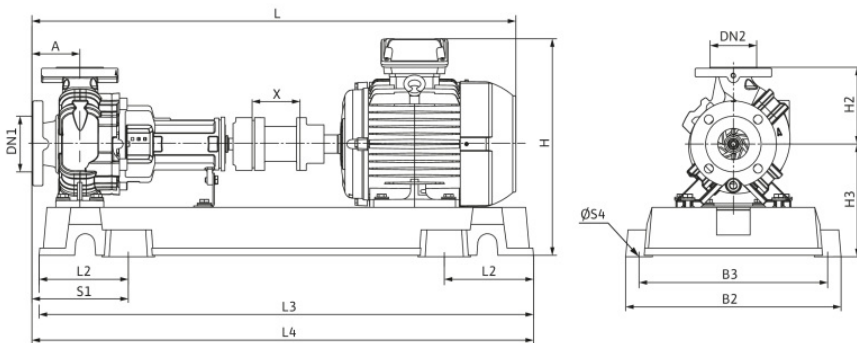

#### Dimensions

mm

A	100	H	562	L3	1,150
B2	490	H2	180	L4	1,175
B3	440	H3	283	S1	230
DN1	DN 65, P	L	1,224	S4	24
DN2	DN 40, P	L2	205	X	100



Contact  
E-mail  
Phone

**Customer**

Contact  
E-mail  
Phone

## Hydraulic data

Glanded standard pump  
Atmos GIGA-N 40/200-22/2/6

Project ID: Untitled project 2025-03-05 00:23:19.113

Project name  
Installation location  
Customer pos. No.

Date: 2025-03-05

### Operating data

Rotational speed <b>3480 1/min</b>	Frequency <b>60 Hz</b>	Duty point <b>Q =</b>	<b>H =</b>	Suction port <b>DN 65</b>	Discharge port <b>DN 40</b>
---------------------------------------	---------------------------	--------------------------	------------	------------------------------	--------------------------------

Power data referred to: Water; 20°C; 998.3kg/m<sup>3</sup>; 1.005mm<sup>2</sup>/s ±10 % tolerance with linear U/f frequency control

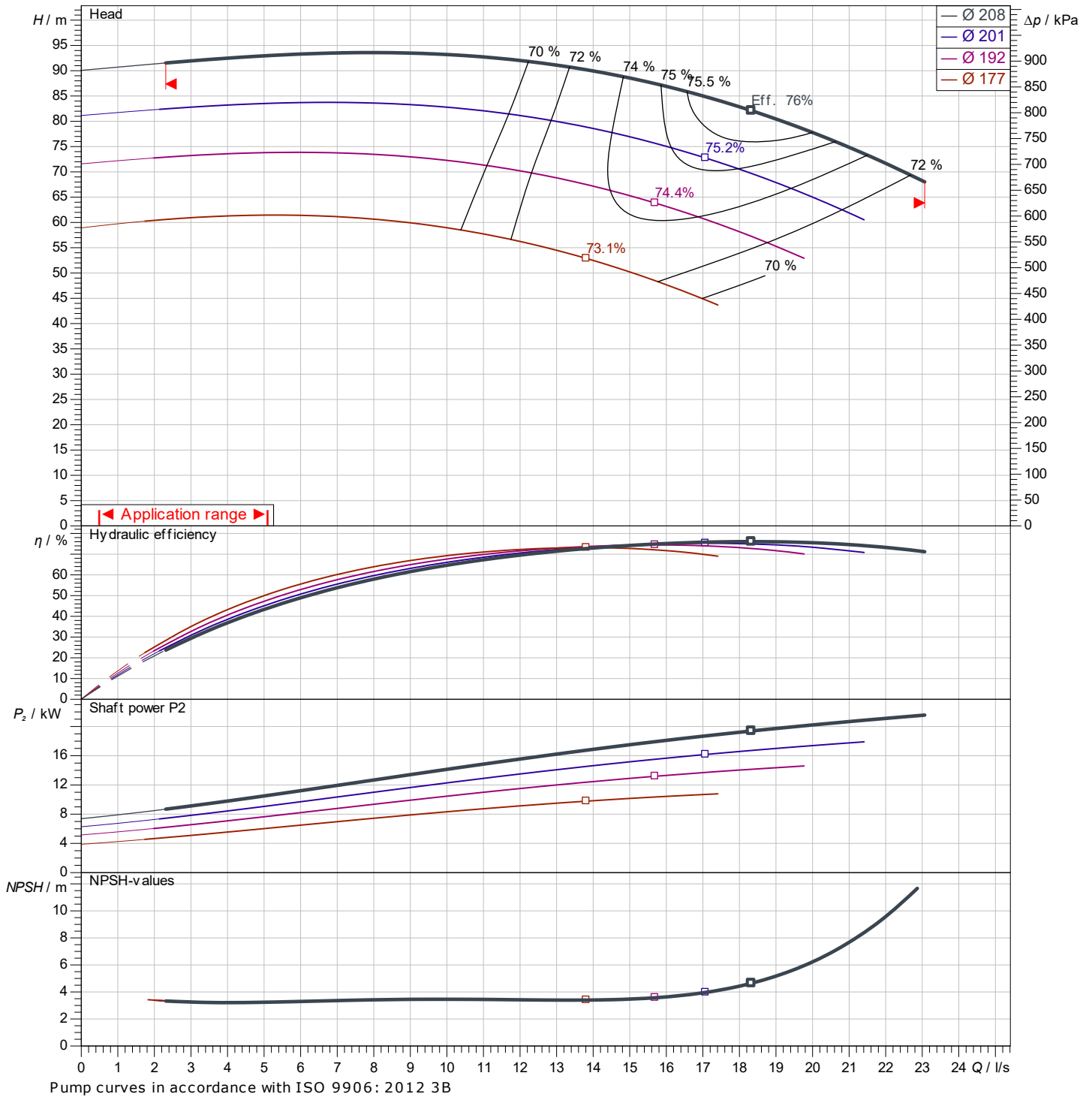

Contact  
E-mail  
Phone

**Customer**

Contact  
E-mail  
Phone

## Dimensions

Glanded standard pump  
Atmos GIGA-N 40/200-22/2/6

Project ID                      Untitled project 2025-03-05 00:23:19.113

Project name  
Installation location  
Customer pos. No.

Date                      2025-03-05



Coupling with spacer

Suction side                      DN 65, PN 16  
Discharge side                      DN 40, PN 16

**Dimensions**                      mm

Name	Value	Name	Value	Name	Value	Name	Value
A	100	H3	283	X	100		
B2	490	L	1,224				
B3	440	L2	205				
DN1	DN 65, PN 16	L3	1,150				
DN2	DN 40, PN 16	L4	1,175				
H	562	S1	230				
H2	180	S4	24				