

Customer

Technical data

Glanded monobloc pump Atmos BST 25/130-1.1/2-V4

Project ID Untitled project 2025-03-01 17:12:44.130

Project name
Installation location
Customer pos. No.

Date 2025-03-01

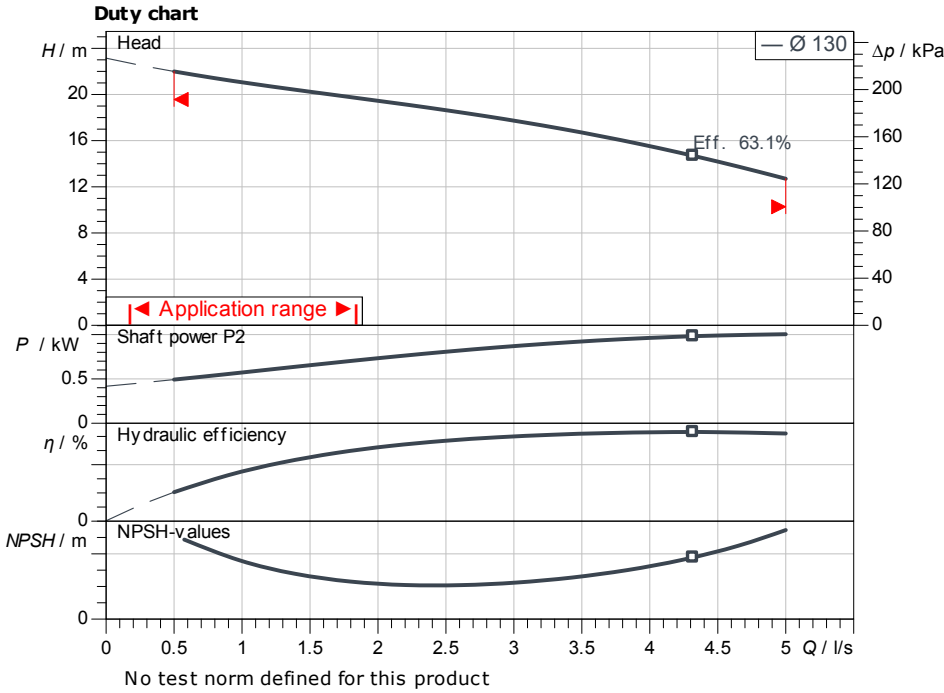

Requested data

Flow	
Head	
Media	Water 100 %
Fluid temperature	20.00 °C
Density	998.30 kg/m ³
Kin. viscosity	1.00 mm ² /s

Hydraulic data (Duty point)

Flow	
Head	
Shaft power P2	
Hydraulic efficiency	
NPSH	
Impeller size	130

Product data

Glanded monobloc pump	
Atmos BST 25/130-1.1/2-V4	
Max. operating pressure	1,000 kPa
Fluid temperature	-20 °C ... +120 °C
Max. ambient temperature	50 °C
Minimum efficiency index (MEI)	≥ 0.4

Motordata per Motor/Pump

Motor efficiency level	IE2
Mains connection	1~ 230 V / 50 Hz
Permitted voltage tolerance	+6 %
Max. speed	2,900 1/min
Rated power P2	1.10 kW
Rated current	6.70 A
Power factor	0.95
Efficiency	
50% / 75% / 100%	//%
Degree of protection	IP55
Insulation class	F
Motor protection	PTC

Fitting dimensions

Pipe connection on the suction side	G 1 1/2, PN 10
Pipe connection (pressure side)	G 1, PN 10
Port to Port	

Materials

Pump housing	1.4301
Impeller	1.4301
Shaft	1.4301
Shaft seal	B9Q1EF

Information for order placements

Weight approx.	
Item number	9187041

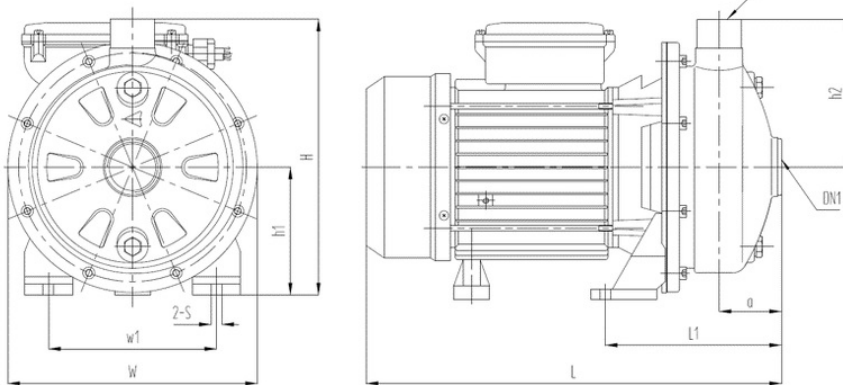

Dimensions		mm	
A	53	H2	121
DN1	G 1 1/2, PN	L	347
DN2	G 1, PN 1	L1	148
H	227	W	208
H1	106	W1	140



Contact
E-mail
Phone

Customer

Contact
E-mail
Phone

Hydraulic data

Glanded monobloc pump
Atmos BST 25/130-1.1/2-V4

Project ID: Untitled project 2025-03-01 17:12:44.130

Project name
Installation location
Customer pos. No.

Date: 2025-03-01

Operating data

Rotational speed 2871 1/min	Frequency 50 Hz	Duty point Q =	H =	Suction port G 1½	Discharge port G 1
---------------------------------------	---------------------------	--------------------------	------------	-----------------------------	------------------------------

Power data referred to: Water; 20°C; 998.3kg/m³; 1.005mm²/s ±10 % tolerance with linear U/f frequency control

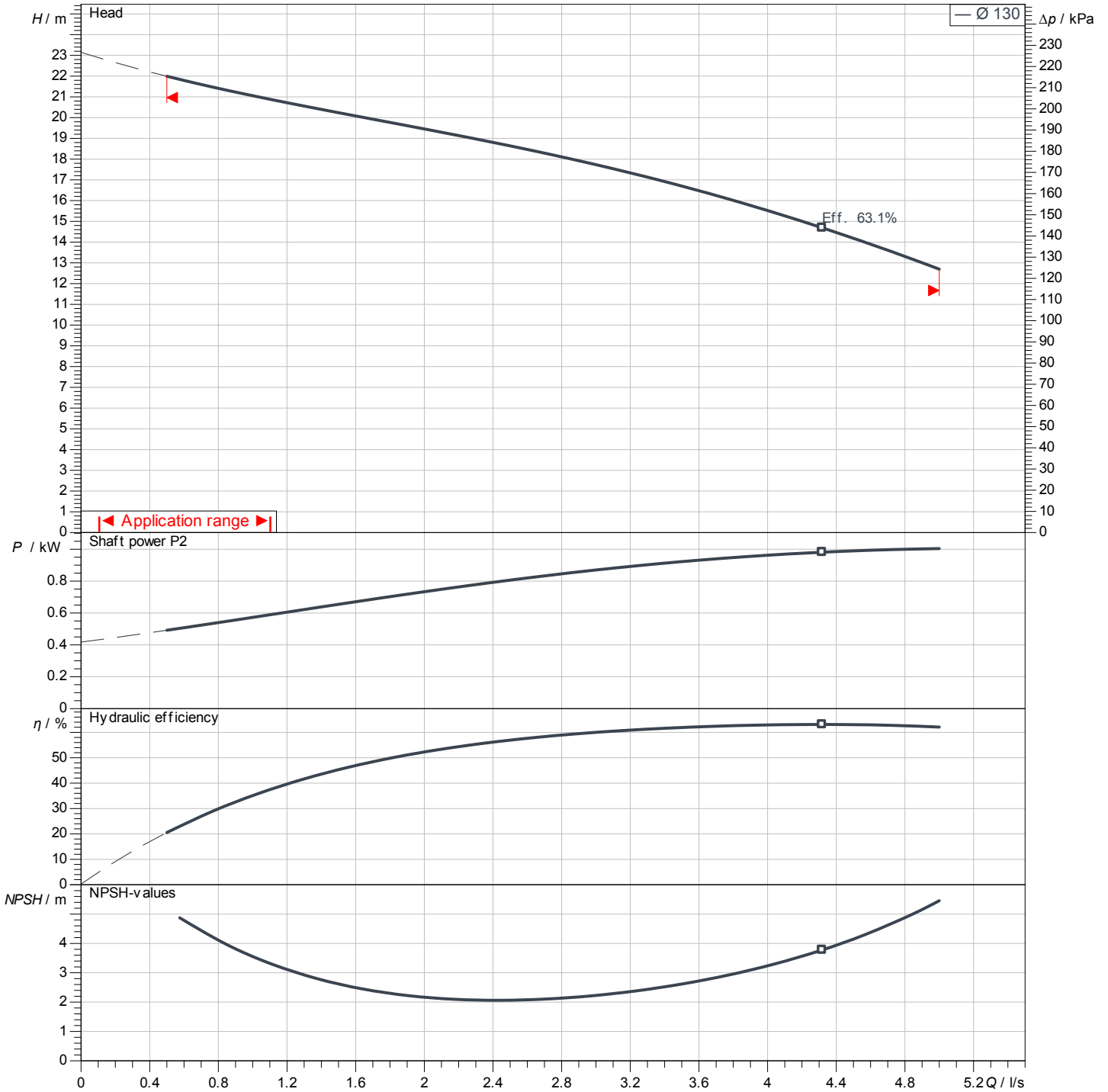

No test norm defined for this product

Contact
E-mail
Phone

Customer

Contact
E-mail
Phone

Dimensions

Glanded monobloc pump
Atmos BST 25/130-1.1/2-V4

Project ID Untitled project 2025-03-01 17:12:44.130

Project name
Installation location
Customer pos. No.

Date 2025-03-01

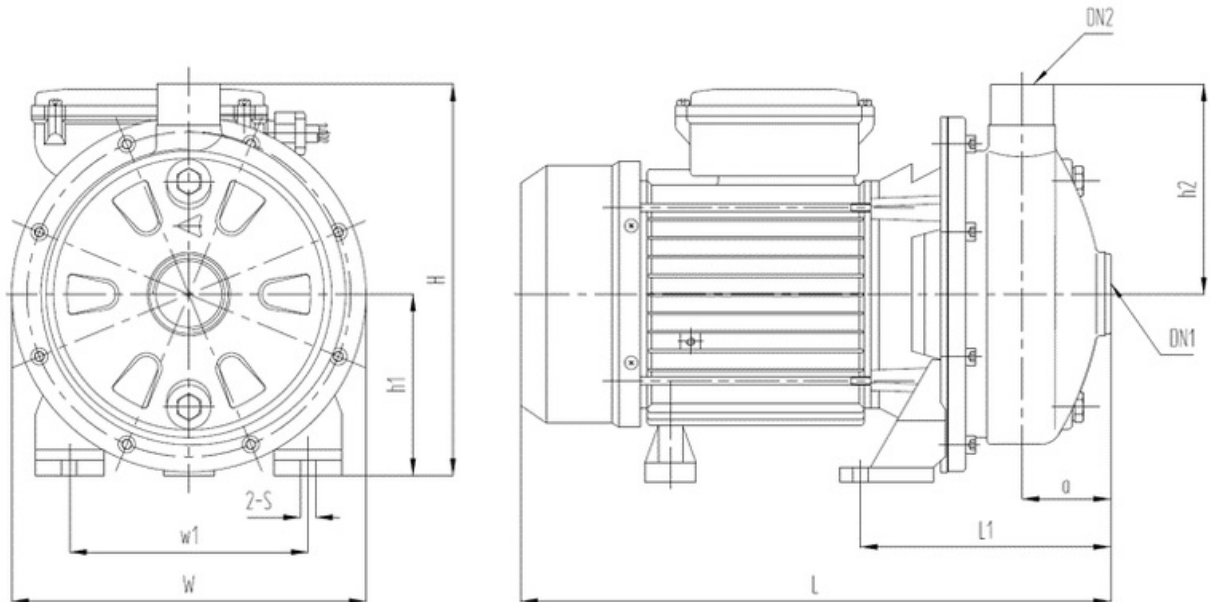

Standard

Suction side G 1½, PN 10
Discharge side G 1, PN 10

Dimensions mm

Name	Value	Name	Value	Name	Value	Name	Value
A	53	L1	148				
DN1	G 1½, PN 10	W	208				
DN2	G 1, PN 10	W1	140				
H	227						
H1	106						
H2	121						
L	347						