

**Customer**

## Technical data

### Glanded monobloc pump Atmos BST 32/160-2.2/2-H12-V1

Project ID: Untitled project 2025-03-01 17:12:44.130

Project name  
Installation location  
Customer pos. No.

Date: 2025-03-01

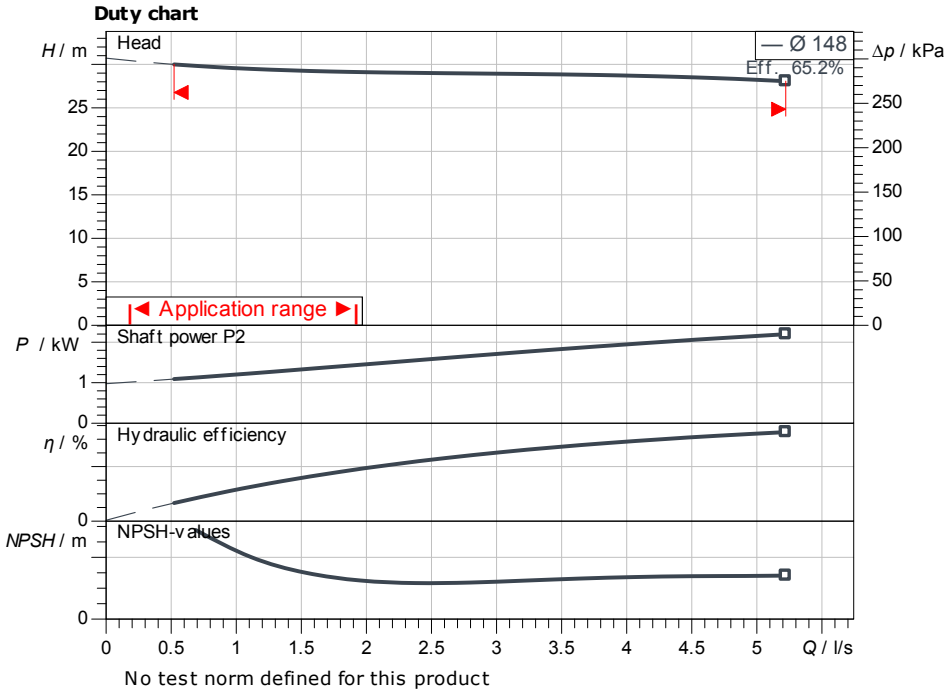

**Requested data**

Flow  
Head  
Media: Water 100 %  
Fluid temperature: 20.00 °C  
Density: 998.30 kg/m<sup>3</sup>  
Kin. viscosity: 1.00 mm<sup>2</sup>/s

**Hydraulic data (Duty point)**

Flow  
Head  
Shaft power  $P_2$   
Hydraulic efficiency  
NPSH  
Impeller size: 148

**Product data**

Glanded monobloc pump  
Atmos BST 32/160-2.2/2-H12-V1  
Max. operating pressure: 1,000 kPa  
Fluid temperature: -20 °C ... +120 °C  
Max. ambient temperature: 50 °C  
Minimum efficiency index (MEI):  $\geq 0.4$

**Motordata per Motor/Pump**

Motor efficiency level: IE3  
Mains connection: 3~ 400 V / 50 Hz  
Permitted voltage tolerance: +6 %  
Max. speed: 2,900 1/min  
Rated power  $P_2$ : 2.20 kW  
Rated current: 4.30 A  
Power factor: 0.85  
Efficiency: 50% / 75% / 100% // %  
Degree of protection: IP55  
Insulation class: F  
Motor protection

**Fitting dimensions**

Pipe connection on the suction side: DN 50, PN 16  
Pipe connection (pressure side): DN 32, PN 16  
Port to Port

**Materials**

Pump housing: 1.4401  
Impeller: 1.4401  
Shaft: 1.4401  
Shaft seal: B3Q1EG

**Information for order placements**

Weight approx.  
Item number: 9187137

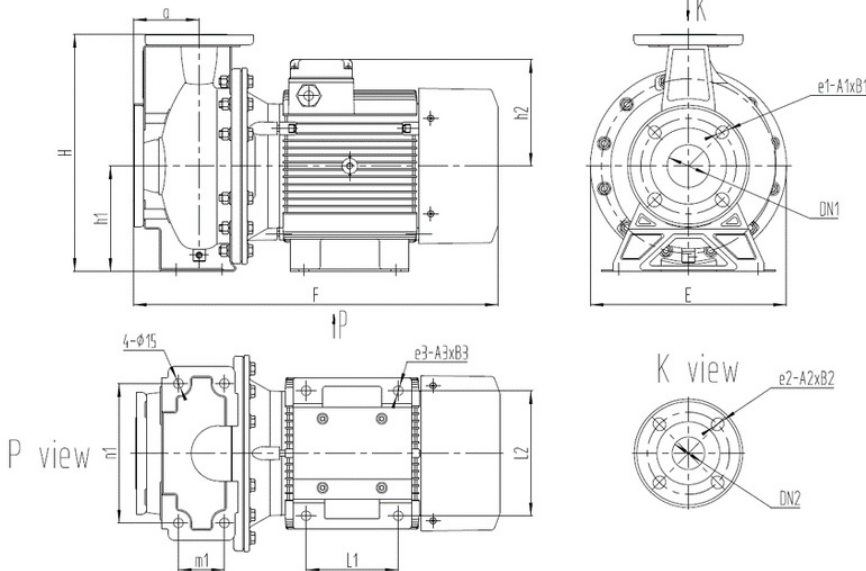

**Dimensions**

mm

A	80	B2	20	E	215	L1	100
A1	18	B3	18	F	437	L2	160
A2	18	dL	18	H	255	M1	70
A3	12	DN1	DN 50, P	H1	112	n1	160
B1	20	DN2	DN 32, P	H2	112	Ø k	125



Contact  
E-mail  
Phone

Customer

Contact  
E-mail  
Phone

# Hydraulic data

Glanded monobloc pump  
Atmos BST 32/160-2.2/2-H12-V1

Project ID: Untitled project 2025-03-01 17:12:44.130

Project name  
Installation location  
Customer pos. No.

Date: 2025-03-01

## Operating data

Rotational speed <b>2869 1/min</b>	Frequency <b>50 Hz</b>	Duty point <b>Q =</b>	<b>H =</b>	Suction port <b>DN 50</b>	Discharge port <b>DN 32</b>
---------------------------------------	---------------------------	--------------------------	------------	------------------------------	--------------------------------

Power data referred to: Water; 20°C; 998.3kg/m³; 1.005mm²/s ±10 % tolerance with linear U/f frequency control

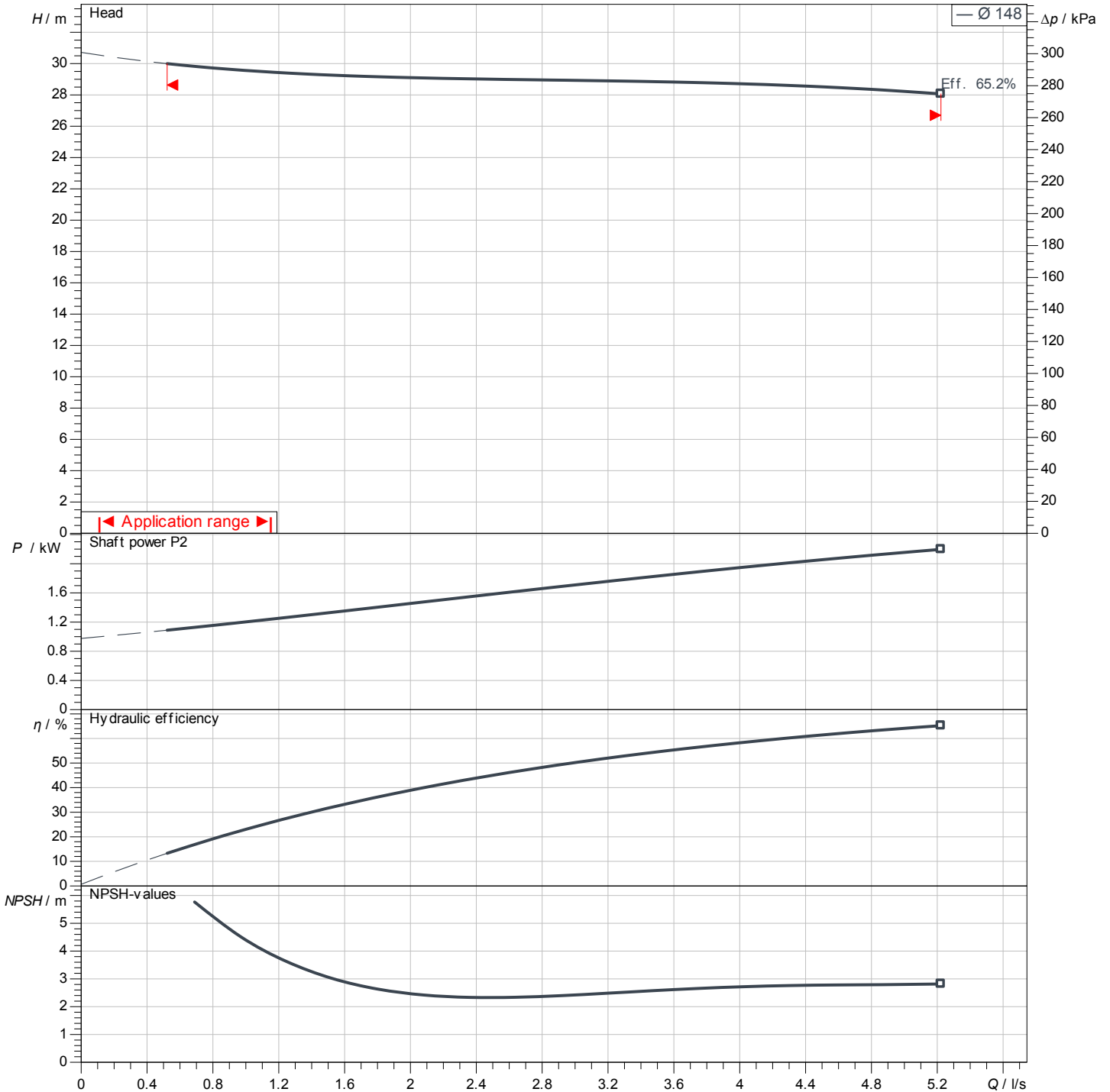

No test norm defined for this product

Contact  
E-mail  
Phone

**Customer**

Contact  
E-mail  
Phone

## Dimensions

Glanded monobloc pump  
Atmos BST 32/160-2.2/2-H12-V1

Project ID                      Untitled project 2025-03-01 17:12:44.130

Project name  
Installation location  
Customer pos. No.

Date                      2025-03-01

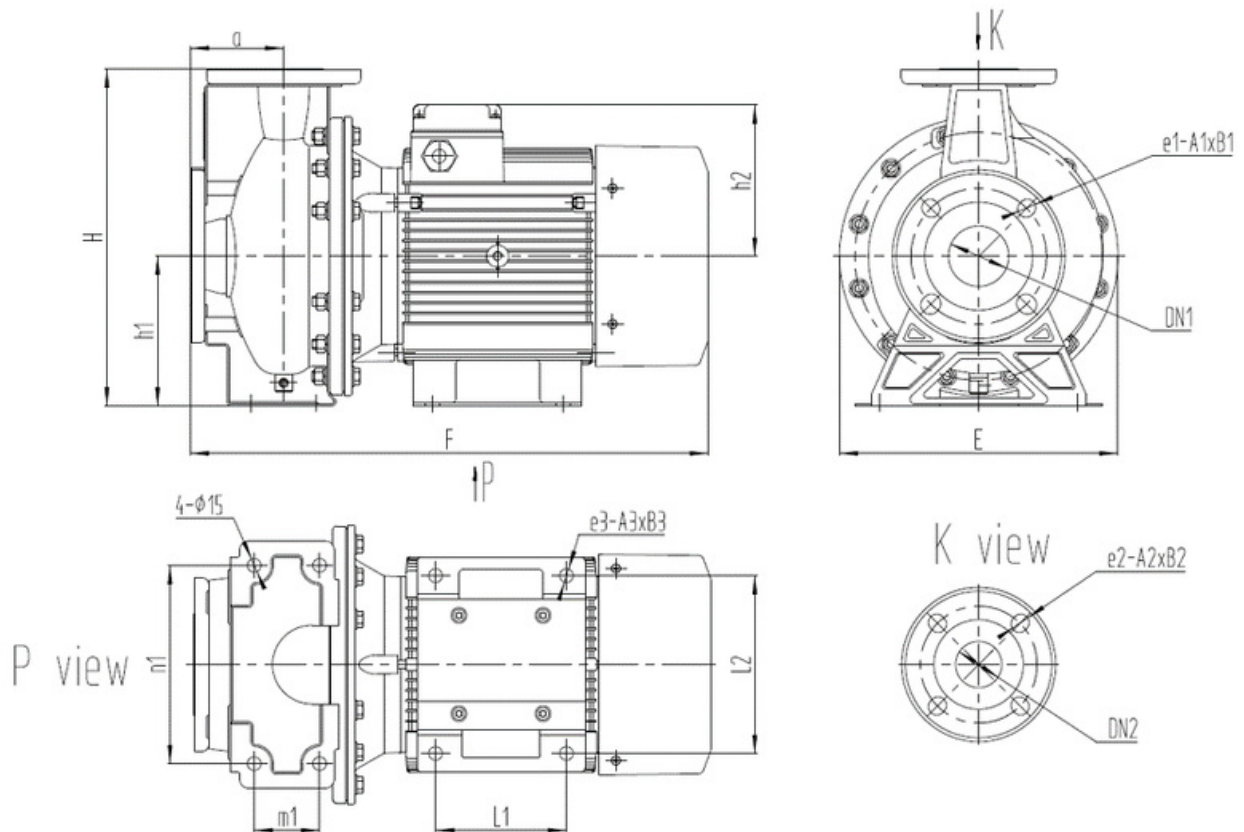

Standard

Suction side                      DN 50, PN 16

Discharge side                    DN 32, PN 16

**Dimensions**                    mm

Name	Value	Name	Value	Name	Value	Name	Value
A	80	dL	18	H2	112	Ø D	165
A1	18	DN1	DN 50, PN 16	L1	100		
A2	18	DN2	DN 32, PN 16	L2	160		
A3	12	E	215	M1	70		
B1	20	F	437	n1	160		
B2	20	H	255	Ø k	125		
B3	18	H1	112	Ø d	99		