

Customer

Technical data

High-pressure multistage centrifugal pump HiMulti 3 H 50/2-24

Project ID Untitled project 2025-03-03 15:12:38.853

Project name
Installation location
Customer pos. No.

Date 2025-03-03

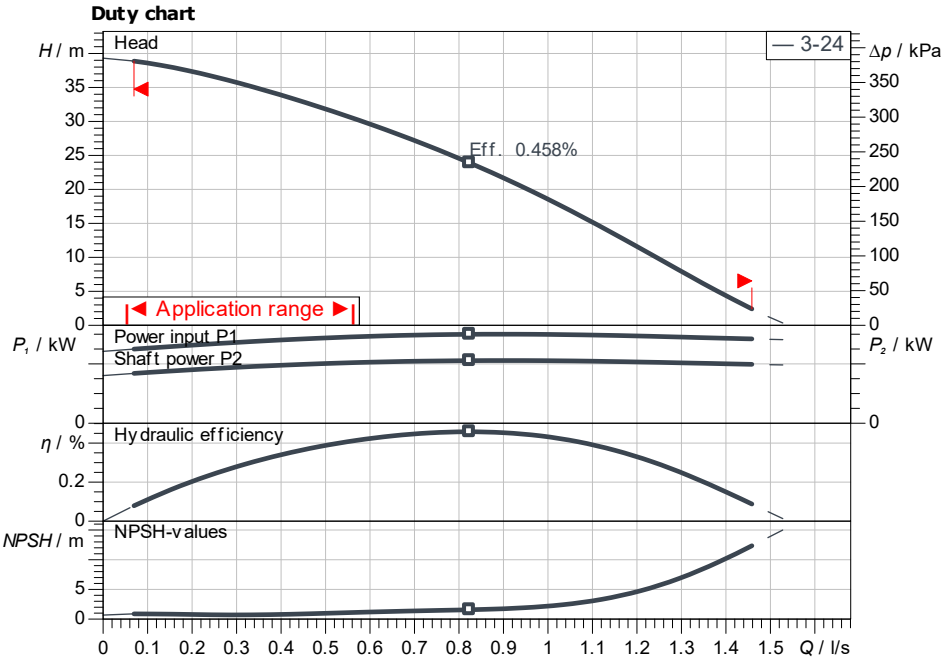

Requested data

Flow	
Head	
Media	Water 100 %
Fluid temperature	20.00 °C
Density	998.30 kg/m ³
Kin. viscosity	1.00 mm ² /s

Hydraulic data (Duty point)

Flow
Head

Product data

High-pressure multistage centrifugal pump	
HiMulti 3 H 50/2-24	
Max. operating pressure	800 kPa
Inlet pressure max.	300 kPa
Fluid temperature	0 °C ... +40 °C
Max. ambient temperature	40 °C
Volume tank	50 l
Degree of protection	X4

Motordata per Motor/Pump

Mains connection	1 ~ 230 V / 50 Hz
Permitted voltage tolerance	+10/-15 %
Max. speed	2,900 1/min
Rated power P_2	0.40 kW
Rated current	2.70 A
0	

Insulation class	F
Motor protection	PTO

Fitting dimensions

Pipe connection on the suction side	G 1, PN 8
Pipe connection (pressure side)	Rp 1, PN 6/10

Materials

Impeller	PPE/PS-GF30
Motor housing	1.4034
Shaft seal	BVPFF
Stage chamber material	PPE/PS-GF30
Pump housing	PA6T/6I-GF40

Information for order placements

Weight approx.	19.4 kg
Item number	2549348

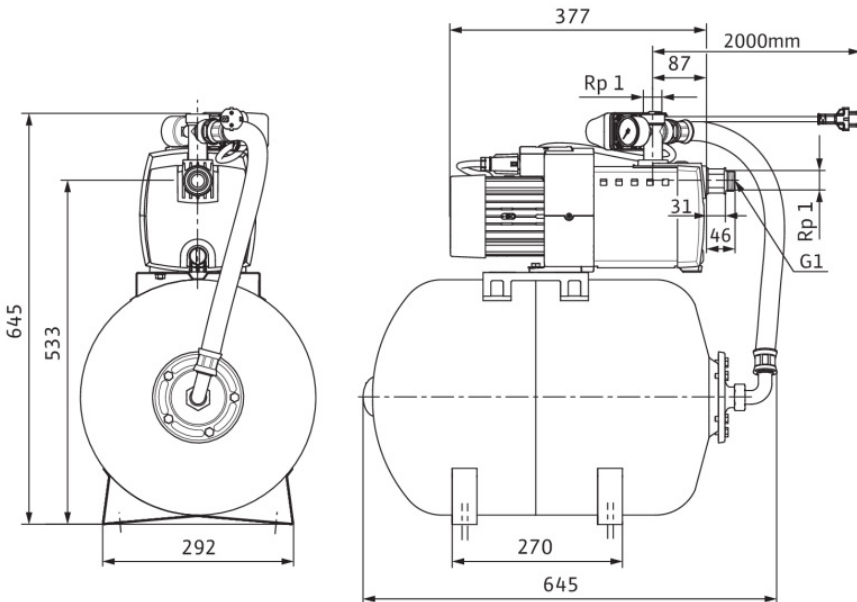

Dimensions mm