

Customer

Technical data

High-pressure multistage centrifugal pump Helix V 2202/2-1/16/E/KS/460-60

Project ID: Untitled project 2025-03-17 12:48:10.989

Project name
Installation location
Customer pos. No.

Date: 2025-03-17

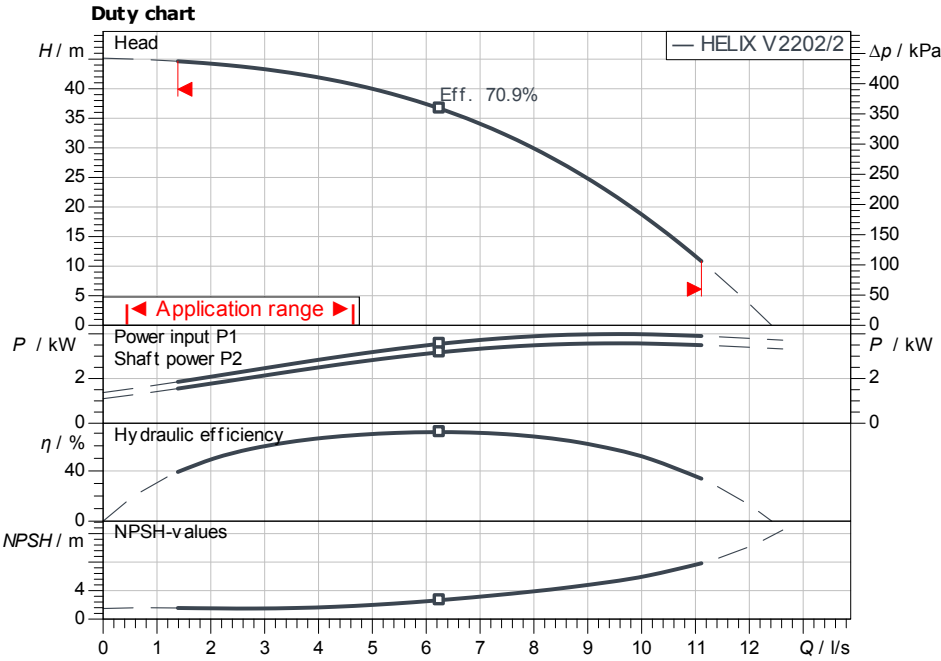

Dimensions

H	804
H2	498
X	155

mm

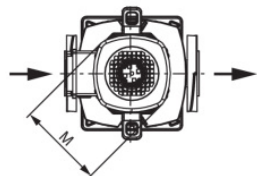
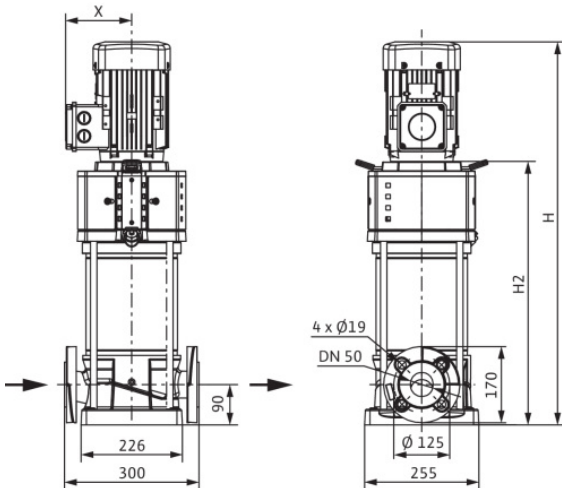
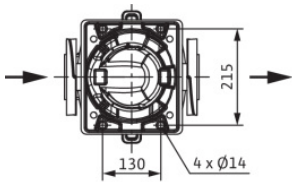

Requested data

Flow	
Head	
Media	Water 100 %
Fluid temperature	20.00 °C
Density	998.30 kg/m ³
Kin. viscosity	1.00 mm ² /s

Hydraulic data (Duty point)

Flow	
Head	
Shaft power P2	
Hydraulic efficiency	
NPSH	

Product data

High-pressure multistage centrifugal pump Helix V 2202/2-1/16/E/KS/460-60	
Max. operating pressure	1,600 kPa
Inlet pressure max.	10 bar
Fluid temperature	-20 °C ... +120 °C
Max. ambient temperature	50 °C
Minimum efficiency index (MEI)	

Motordata per Motor/Pump

Motor efficiency level	
Mains connection	3~ 380 V / 60 Hz
Permitted voltage tolerance	+ -10 %
Max. speed	2,935 1/min
Rated power P2	4.00 kW
Rated current	7.60 A
Power factor	0.93
Service factor	1.15
Efficiency	
50% / 75% / 100%	/89/88.5%
Degree of protection	IP55
Insulation class	
Motor protection	PTC

Fitting dimensions

Pipe connection on the suction side	DN 50, PN 16
Pipe connection (pressure side)	DN 50, PN 16

Materials

Pump housing	1.4301
Impeller	1.4307
Shaft	1.4057
Shaft seal	BQ7EGG
Gasket material	EPDM

Information for order placements

Weight approx.	71 kg
Item number	4246577