



**Customer**

## Technical data

### Glanded monobloc pump BM-S 50/250-22/2

Project ID                      Untitled project 2025-03-01 21:27:50.947

Project name  
Installation location  
Customer pos. No.

Date                      2025-03-01

#### Duty chart

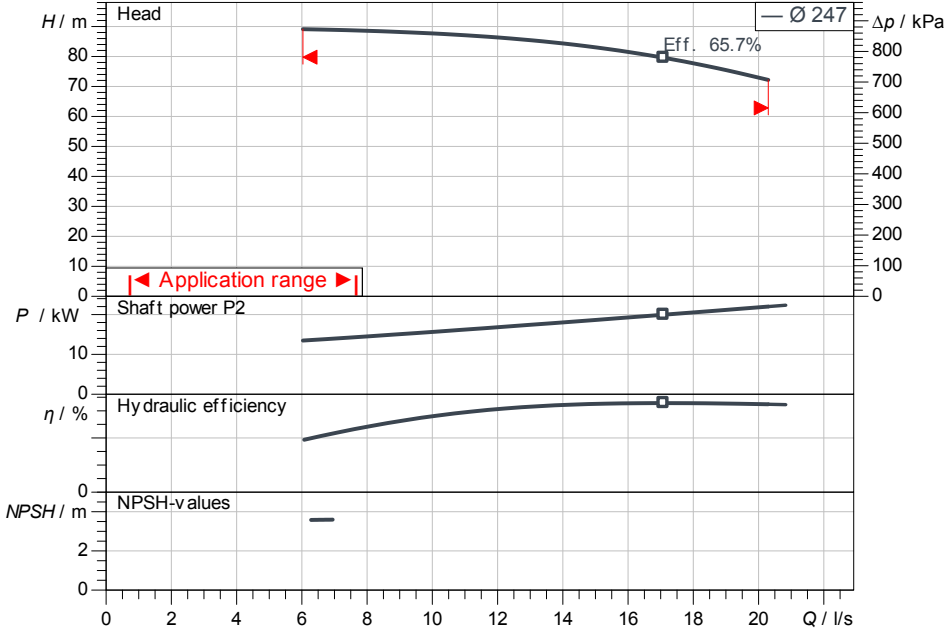

#### Requested data

Flow  
Head  
Media                      Water 100 %  
Fluid temperature                      20.00 °C  
Density                      998.30 kg/m<sup>3</sup>  
Kin. viscosity                      1.00 mm<sup>2</sup>/s

#### Hydraulic data (Duty point)

Flow  
Head  
Shaft power P2  
Hydraulic efficiency  
NPSH

#### Product data

Glanded monobloc pump  
BM-S 50/250-22/2  
Max. operating pressure                      1,000 kPa  
Fluid temperature                      -10 °C ... +90 °C  
Max. ambient temperature                      40 °C  
Minimum efficiency index (MEI)                      ≥ 0.4

#### Motordata per Motor/Pump

Motor efficiency level                      IE3  
Mains connection                      3~ 400 V / 50 Hz  
Permitted voltage tolerance                      + -10 %  
Rated speed                      2,900 1/min  
Rated power P2                      22.00 kW  
Rated current                      39.20 A  
Power factor                      0.88  
Efficiency                      50% / 75% / 100%                      92.5/ 92.9/ 92.7%  
Degree of protection                      IP55  
Insulation class                      F  
Motor protection                      No

#### Fitting dimensions

Pipe connection on the suction side                      DN 65, PN 10  
Pipe connection (pressure side)                      DN 50, PN 10  
Port to Port                      -

#### Materials

Pump housing                      1.4408  
Impeller                      1.4408  
Shaft                      1.4362  
Shaft seal                      Q1Q1VGG

#### Information for order placements

Weight approx.                      147 kg  
Item number                      2103445

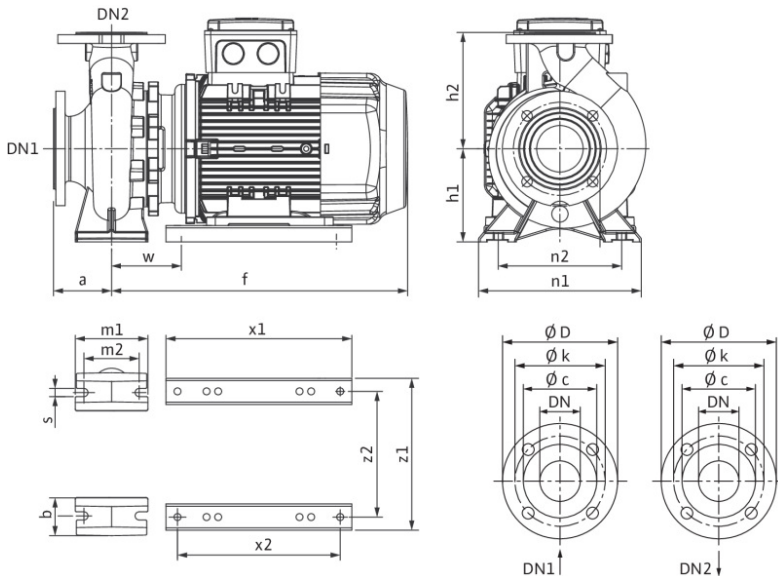



Contact  
E-mail  
Phone

Customer

Contact  
E-mail  
Phone

# Hydraulic data

Glanded monobloc pump  
BM-S 50/250-22/2

Project ID: Untitled project 2025-03-01 21:27:50.947

Project name  
Installation location  
Customer pos. No.

Date 2025-03-01

## Operating data

Rotational speed <b>2900 1/min</b>	Frequency <b>50 Hz</b>	Duty point <b>Q =</b>	<b>H =</b>	Suction port <b>DN 65</b>	Discharge port <b>DN 50</b>
---------------------------------------	---------------------------	--------------------------	------------	------------------------------	--------------------------------

Power data referred to: Water; 20°C; 998.3kg/m³; 1.005mm²/s ±10 % tolerance with linear U/f frequency control

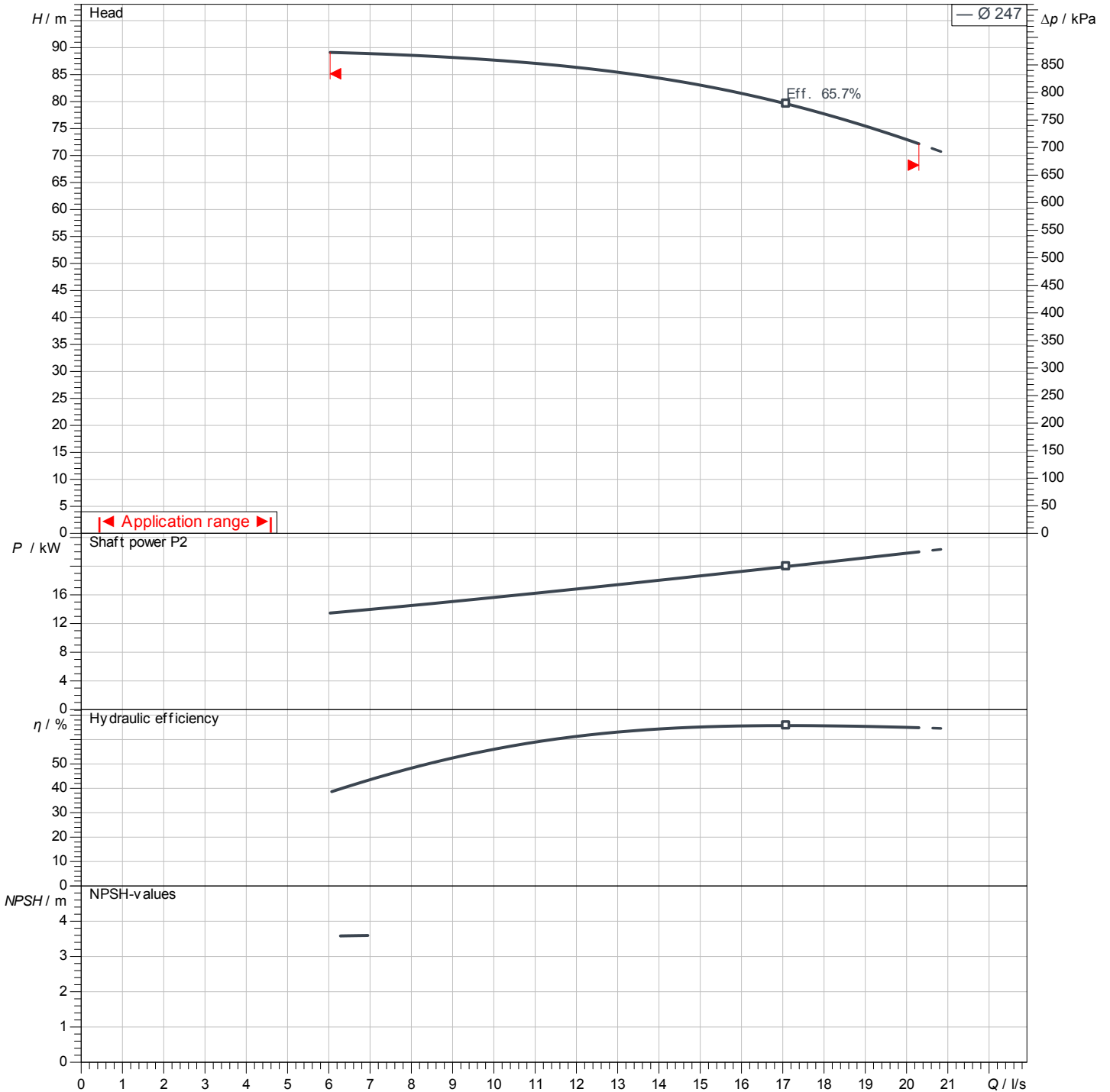

No test norm defined for this product