

**Customer**

## Technical data

### Glanded standard twin-head pump Atmos GIGA-D 125/130-1,5/4

Project ID                      Untitled project 2025-03-01 18:38:40.590

Project name  
Installation location  
Customer pos. No.

Date                      2025-03-01

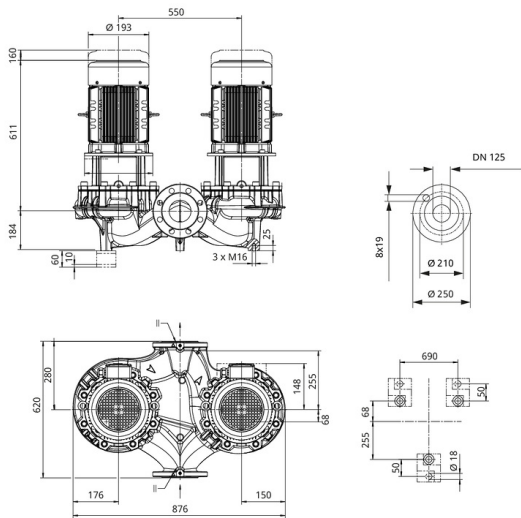
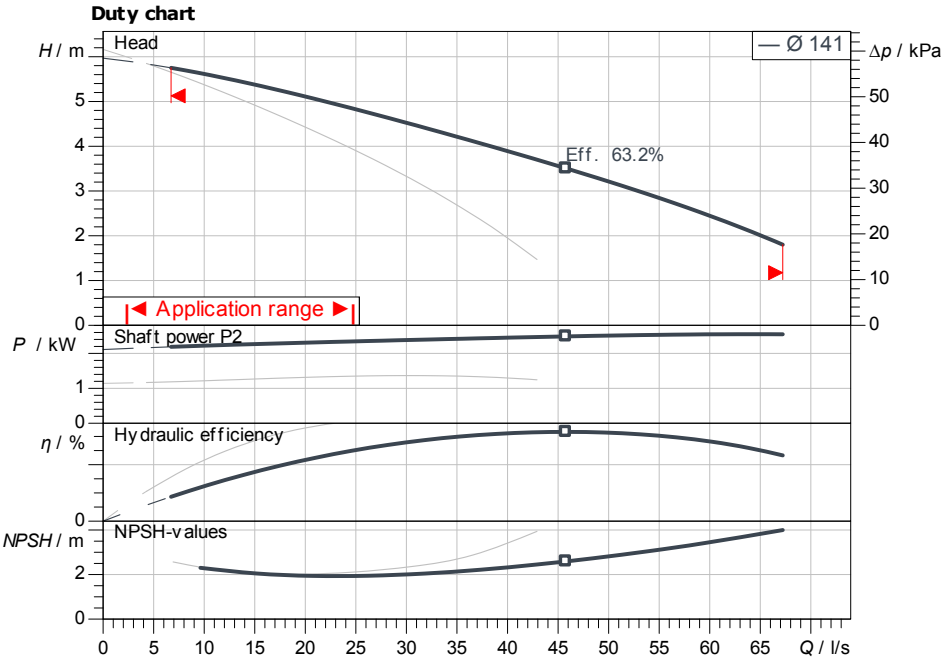

**Requested data**

Flow	
Head	
Media	Water 100 %
Fluid temperature	20.00 °C
Density	998.30 kg/m <sup>3</sup>
Kin. viscosity	1.00 mm <sup>2</sup> /s

**Hydraulic data (Duty point)**

Flow	
Head	
Shaft power $P_2$	
Hydraulic efficiency	
NPSH	

**Product data**

Glanded standard twin-head pump	
Atmos GIGA-D 125/130-1,5/4	
Max. operating pressure	1,600 kPa
Fluid temperature	-20 °C ... +140 °C
Max. ambient temperature	40 °C
Minimum efficiency index (MEI)	≥ 0.4

**Motordata per Motor/Pump**

Motor efficiency level	IE3
Mains connection	3~ 400 V / 50 Hz
Permitted voltage tolerance	+/- 10 %
Rated speed	1,450 1/min
Rated power $P_2$	1.50 kW
Rated current	3.15 A
Power factor	0.84
Efficiency	
50% / 75% / 100%	81.3/ 83.8/84.2%
Degree of protection	IP55
Insulation class	F
Motor protection	No

**Fitting dimensions**

Pipe connection on the suction side	DN 125, PN 16
Pipe connection (pressure side)	DN 125, PN 16
Port to Port	620 mm

**Materials**

Pump housing	5.1301, EN-GJL-250 cataphoretic-coated
Impeller	EN-GJL-200
Lantern	5.1301/EN-GJL-250
Shaft	1.4122
Shaft seal	AQ1EGG

**Information for order placements**

Weight approx.	239 kg
Item number	2225518

