

Customer

Technical data

Glanded standard pump
Atmos GIGA-N 32/160-2-B-IE4

Project ID Untitled project 2025-03-01 20:23:09.313

Project name
Installation location
Customer pos. No.

Date 2025-03-01

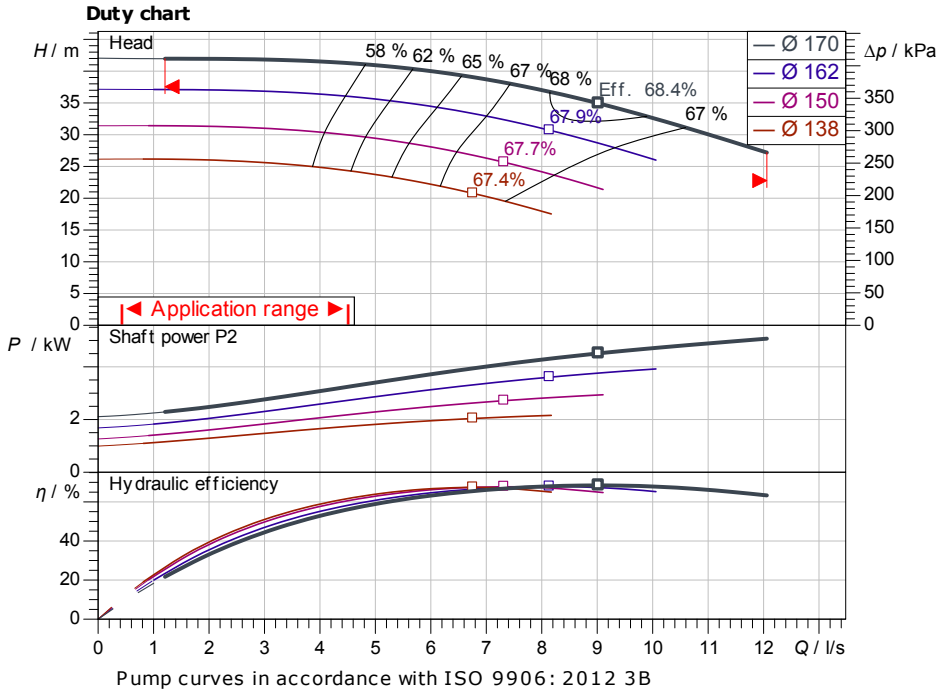

Requested data

Flow
Head
Media Water 100 %
Fluid temperature 20.00 °C
Density 998.30 kg/m³
Kin. viscosity 1.00 mm²/s

Hydraulic data (Duty point)

Flow
Head
Shaft power P_2
Hydraulic efficiency
NPSH
Impeller size 170

Product data

Glanded standard pump
Atmos GIGA-N 32/160-2-B-IE4
Max. operating pressure 1,600 kPa
Fluid temperature -20 °C ... +140 °C
Max. ambient temperature 40 °C
Minimum efficiency index (MEI)

Motordata per Motor/Pump

Motor efficiency level
Mains connection V / Hz
Permitted voltage tolerance
Max. speed
Rated power P_2
Rated current
Power factor
Efficiency
50% / 75% / 100% //%

Fitting dimensions

Pipe connection on the suction side DN 50, PN 16
Pipe connection (pressure side) DN 32, PN 16
Port to Port

Materials

Pump housing 5.1301, EN-GJL-250 c

Impeller EN-GJL-200
Lantern 5.1301/EN-GJL-250
Shaft 1.4021
Shaft seal AQ1EGG

Information for order placements

Weight approx.
Item number

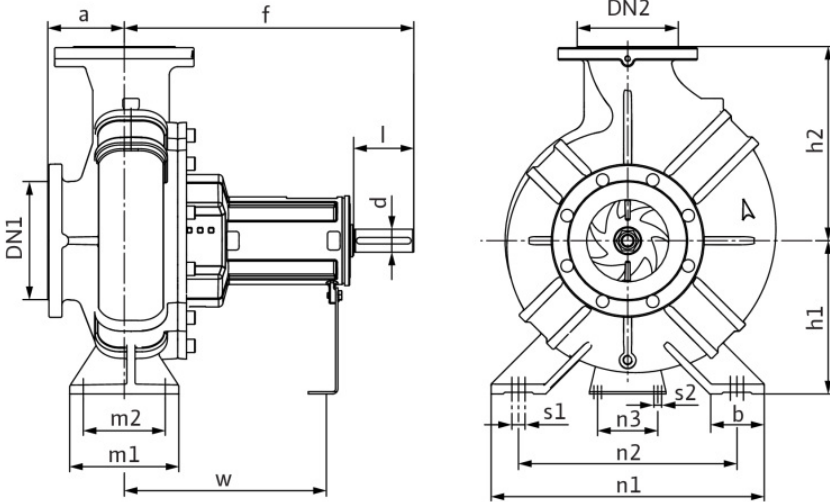

Dimensions

mm

a	80	DN2	DN 32, P	h2	160	n2	190
b	50	f	360	l	50	n3	110
d	24	h1	132	m1	100	Ø k	125
dL	19	h1	132	m2	70	Ø d	99
DN1	DN 50, P	h2	160	n1	240	Ø D	165



Contact
E-mail
Phone

Customer

Contact
E-mail
Phone

Hydraulic data

Glanded standard pump
Atmos GIGA-N 32/160-2-B-IE4

Project ID: Untitled project 2025-03-01 20:23:09.313

Project name
Installation location
Customer pos. No.

Date: 2025-03-01

Operating data

Rotational speed 2917 1/min	Frequency Hz	Duty point Q =	H =	Suction port DN 50	Discharge port DN 32
---------------------------------------	------------------------	--------------------------	------------	------------------------------	--------------------------------

Power data referred to: Water; 20°C; 998.3kg/m³; 1.005mm²/s ±10 % tolerance with linear U/f frequency control

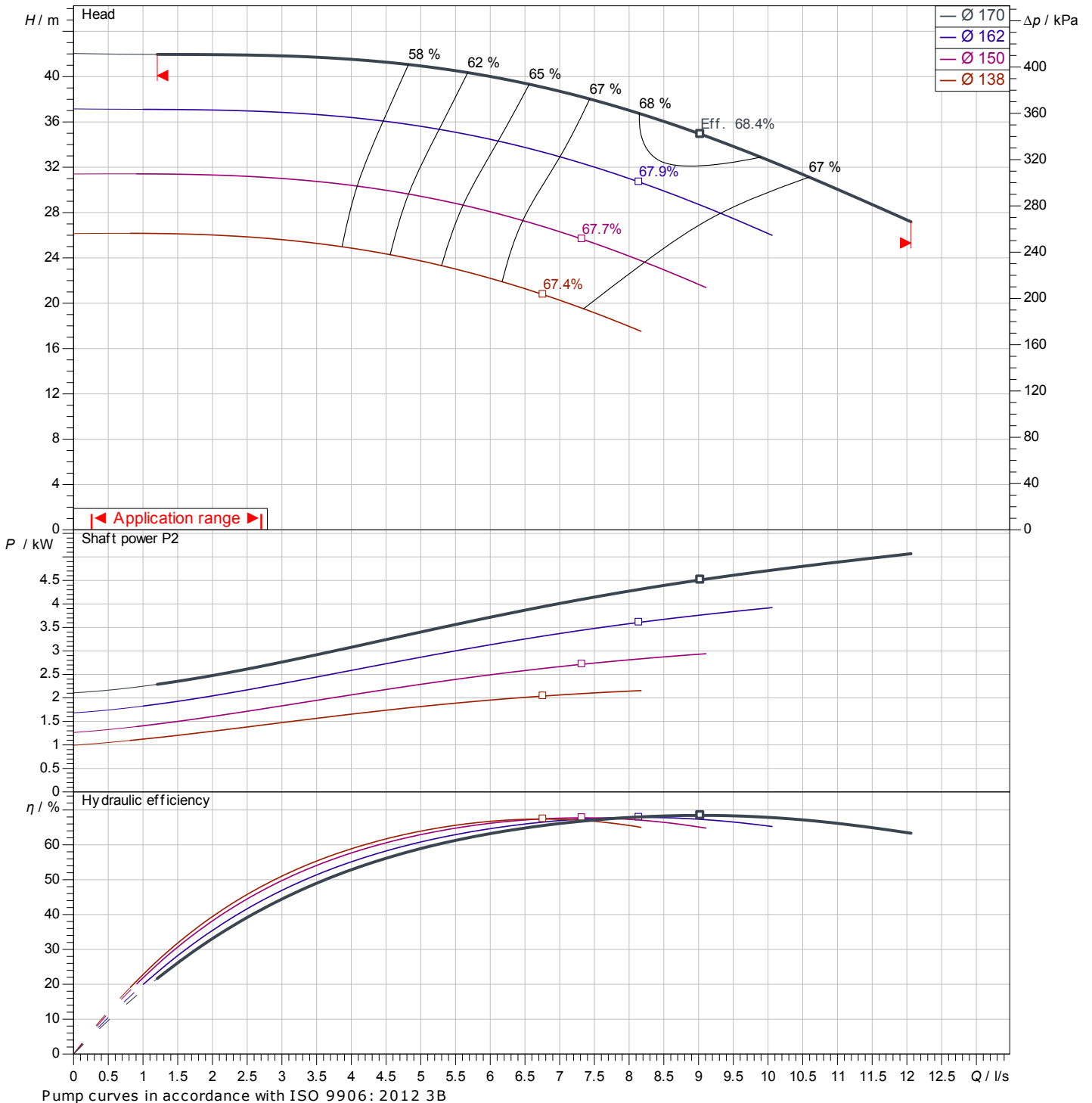

Customer

Dimensions

Glanded standard pump
Atmos GIGA-N 32/160-2-B-IE4

Project ID Untitled project 2025-03-01 20:23:09.313

Project name
Installation location
Customer pos. No.

Date 2025-03-01

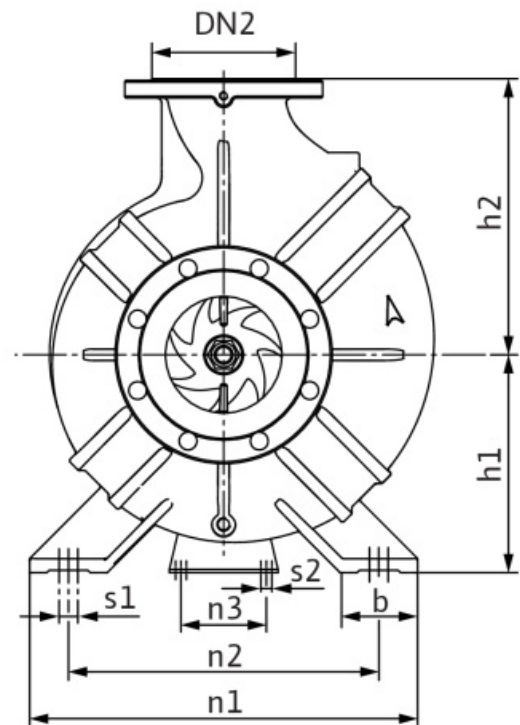
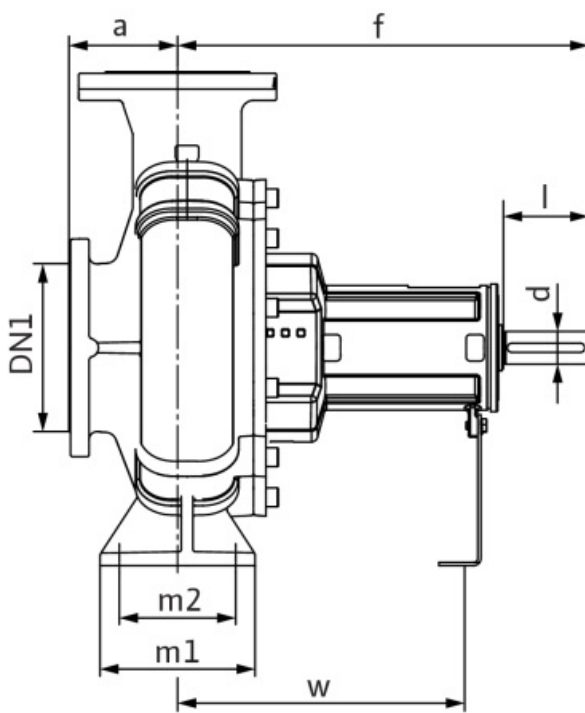

Bareshaft

Suction side DN 50, PN 16
Discharge side DN 32, PN 16

Dimensions mm

Name	Value	Name	Value	Name	Value	Name	Value
a	80	h1	132	n1	240	s2	12
b	50	h1	132	n2	190	w	260
d	24	h2	160	n3	110	x	100
dL	19	h2	160	Ø k	125		
DN1	DN 50, PN 16	l	50	Ø d	99		
DN2	DN 32, PN 16	m1	100	Ø D	165		
f	360	m2	70	s1	12		