

Customer

Technical data

High-pressure multistage centrifugal pump Helix2.0-VE 1603-3.0-1/16/E/KS/3

Project ID: Untitled project 2025-03-03 15:12:38.853

Project name
Installation location
Customer pos. No.

Date: 2025-03-03

Duty chart

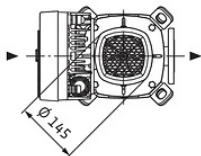
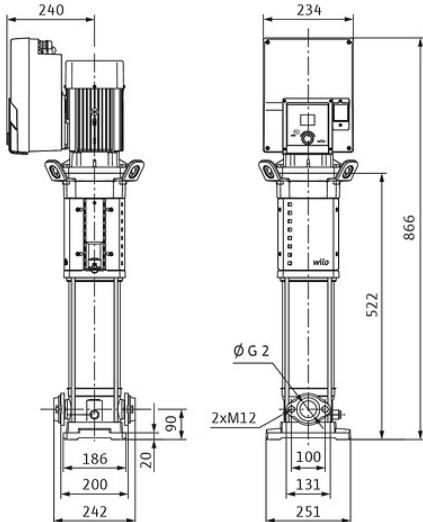
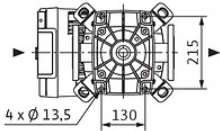
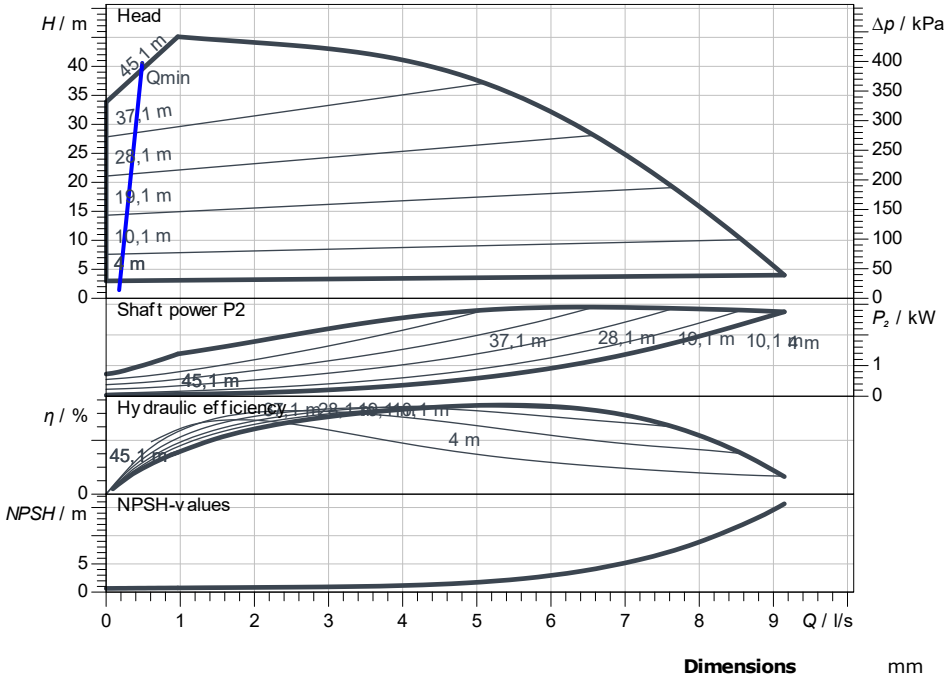

Requested data

Flow	
Head	
Media	Water 100 %
Fluid temperature	20.00 °C
Density	998.30 kg/m ³
Kin. viscosity	1.00 mm ² /s

Hydraulic data (Duty point)

Flow	
Head	
Shaft power P2	
Hydraulic efficiency	
NPSH	

Product data

High-pressure multistage centrifugal pump Helix2.0-VE 1603-3.0-1/16/E/KS/3	
Max. operating pressure	1,600 kPa
Inlet pressure max.	10 bar
Fluid temperature	-30 °C ... +120 °C
Max. ambient temperature	50 °C
Minimum efficiency index (MEI)	≥ 0.5

Motor data per Motor/Pump

Motor efficiency level	IE5
Mains connection	3~ 400 V / 50 Hz
Permitted voltage tolerance	400/50: +/- 10%, 380/6
Rated speed	
Rated power P2	3.00 kW
Rated current	5.30 A
Power factor	
Service factor	0
Degree of protection	IP55
Insulation class	F
Motor protection	

Fitting dimensions

Pipe connection on the suction side	G 2, PN 16
Pipe connection (pressure side)	G 2, PN 16

Materials

Pump housing	1.4301
Impeller	1.4307
Shaft	1.4301
Shaft seal	BQ7EGG
Gasket material	EPDM

Information for order placements

Weight approx.	45.6 kg
Item number	4250830