

Customer

Technical data

Submersible pump Sub TWI 6.60-08-C

Project ID Untitled project 2025-03-17 07:47:37.014

Project name
Installation location
Customer pos. No.

Date 2025-03-17

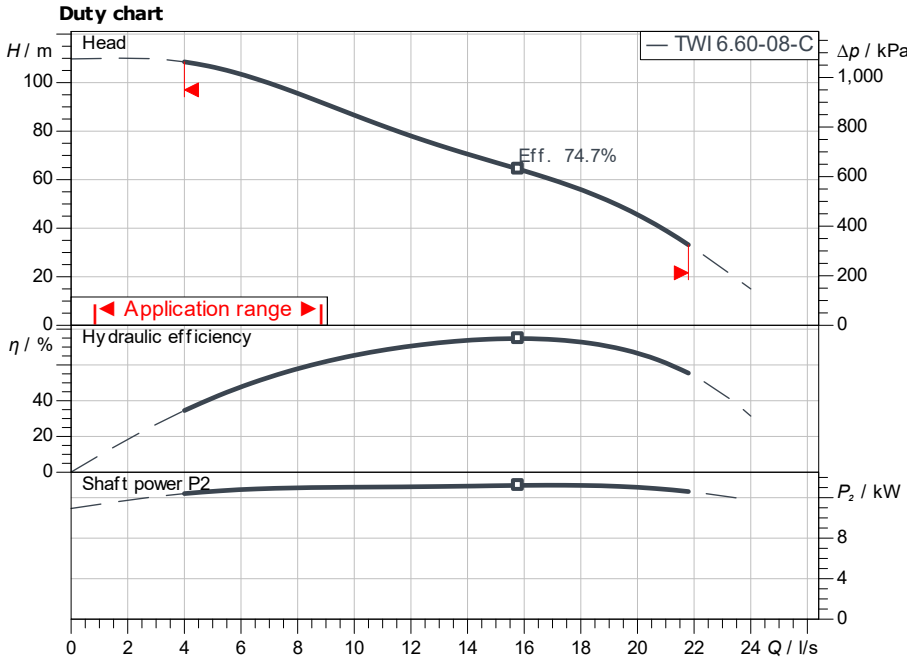

Requested data

Flow	
Head	
Media	Water 100 %
Fluid temperature	20.00 °C
Density	998.30 kg/m ³
Kin. viscosity	1.00 mm ² /s

Hydraulic data (Duty point)

Flow	
Head	
Shaft power P2	
Hydraulic efficiency	
Power input P1	

Product data

Submersible pump	
Sub TWI 6.60-08-C	
Max. operating pressure	4,000 kPa
Fluid temperature	3 °C ... +30 °C
Minimum efficiency index (MEI)	≥ 0.4
Max. pump diameter	152 mm

Motordata per Motor/Pump

Mains connection	3~400 V / 50 Hz
Type of motor	Submersible motor
Activation type	Direct On Line (DOL)
Min. flow at the motor	0.1 m/s
Motor diameter	136.7 mm
Permitted voltage tolerance	+5 %
Nominal speed	2,860 1/min
Rated power P2	15.00 kW
Rated current	32.50 A
Power factor	0.83
Degree of protection	IP68
Insulation class	F

Cable

Length of connecting cable	4 m
Cable type	4G4

Fitting dimensions

Discharge size	Rp 3
Flange standard	-

Materials

Pump housing	1.4301
Motor housing	5.1301/EN-GJL-250
Shaft	1.4057
Impeller	1.4301

Information for order placements

Weight approx.	80 kg
Item number	6075280

Approval

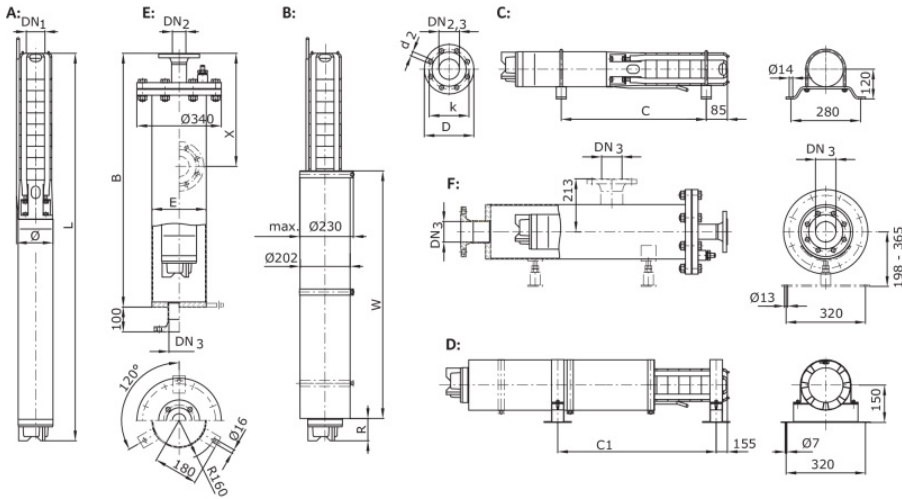

Dimensions

		mm	
B	2,250	L	1,950
c	1,480	W	925
C1	1,432		
e	219.1		