

Customer

Technical data

Solids separation system EMUport CORE 20.2-31/540

Project ID Untitled project 2025-03-03 14:15:38.327

Project name
Installation location
Customer pos. No.

Date 2025-03-03

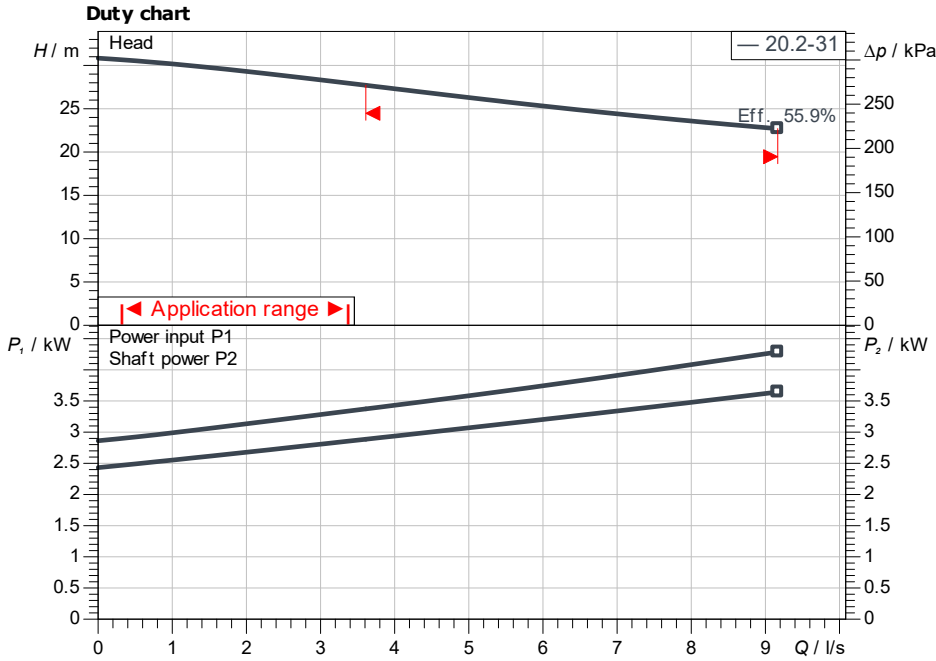

Requested data

Flow	
Head	
Media	Water 100 %
Fluid temperature	20.00 °C
Density	998.30 kg/m ³
Kin. viscosity	1.00 mm ² /s

Hydraulic data (Duty point)

Flow
Head

Product data

Solids separation system	
EMUport CORE 20.2-31/540	
Pump used	
Rexa PRO C08DA-437 + P13.2-16/EAD3-2-T	
No. of pumps	2
Max. operating pressure	341 kPa
Fluid temperature	3 °C ... + 40 °C
Grinder	No
Operating mode (non-immersed)	S3-50%
Gross volume	440 l
Max. switching volume	295 l
Max. sound pressure level	70 dB
Free ball passage	65 mm

Motordata per Motor/Pump

Mains connection	3~ 400 V / 50 Hz
Permitted voltage tolerance	+10 %
Nominal speed	2,868 1/min
Rated power P2	3.65 kW
Power input P1	4.3 kW
Rated current	7.30 A
Activation type	Direct On Line (DOL)
Degree of protection	IP68
Motor protection	Bimetail
Insulation class	F
max. starts per hour	60/h
Motor efficiency level	IE3

Cable

Length of connecting cable	20 m
Mains plug	No
Type of connection cable	Detachable
Cable type	TGSH-J
Cable cross section	7G1,5

Fitting dimensions

Venting	Ø 75
Pipe connection on the suction side	DN 200
Pipe connection (pressure side)	DN 80

Materials

Tank	PE
Pump housing	5.1301/EN-GJL-250
Impeller	5.1301/EN-GJL-250
Shaft	1.4021
Motor housing	5.1301/EN-GJL-250
Gasket material	NBR

Information for order placements

Weight approx.	386 kg
Item number	2554532

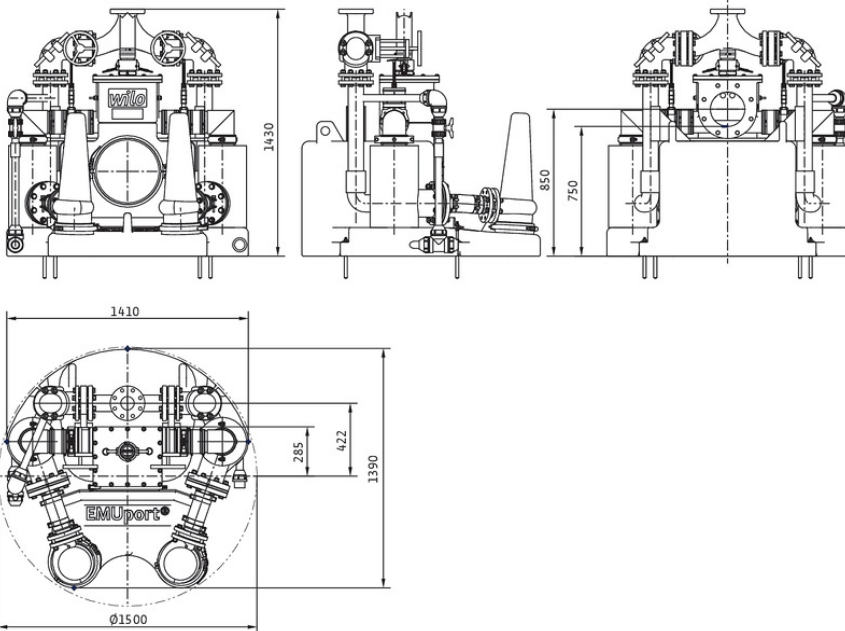

Contact
E-mail
Phone

Customer

Contact
E-mail
Phone

Dimensions

Solids separation system
EMUport CORE 20.2-31/540

Project ID Untitled project 2025-03-03 14:15:38.327

Project name
Installation location
Customer pos. No.

Date 2025-03-03

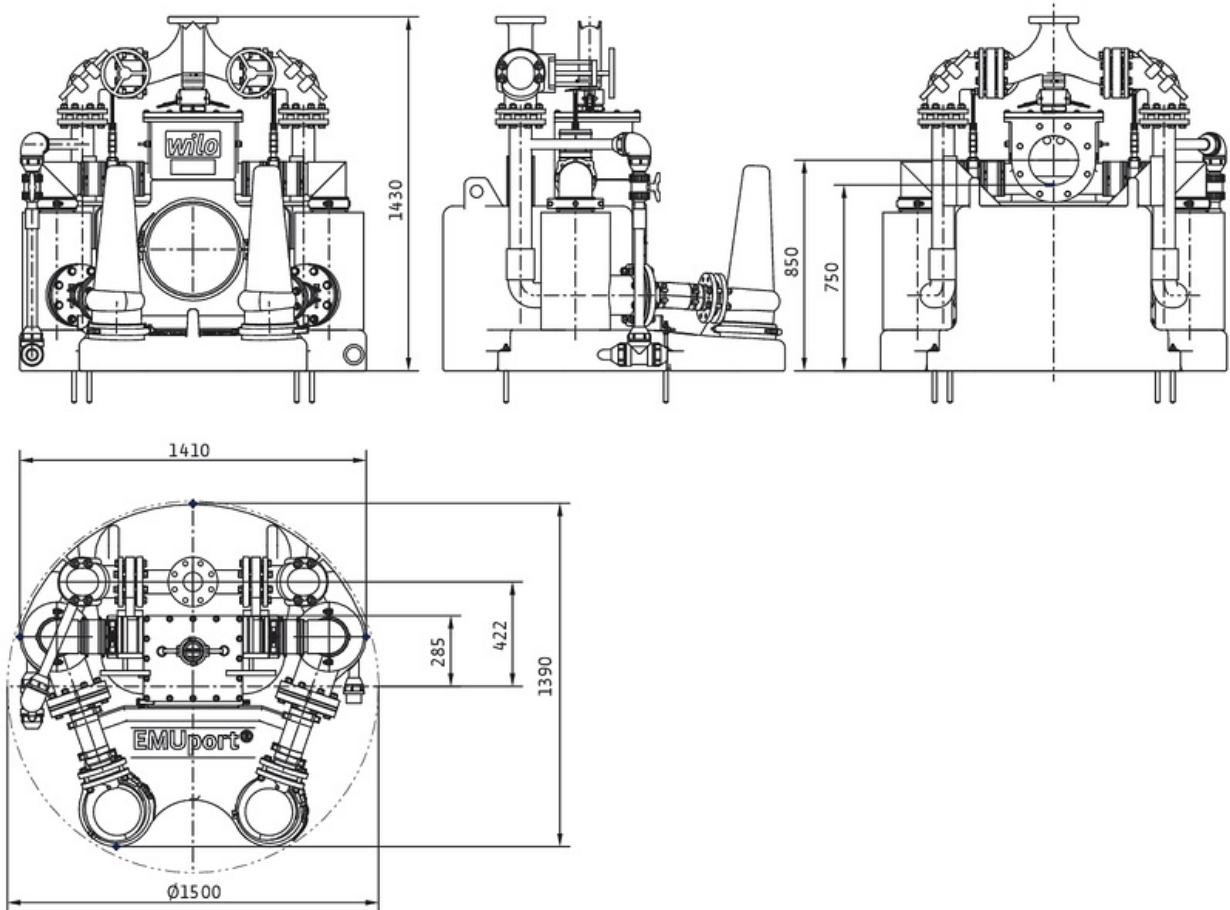

Stationary dry well installation

Suction side DN 200, PN 10

Discharge side DN 80, PN 10

Dimensions mm

Name	Value	Name	Value	Name	Value	Name	Value
------	-------	------	-------	------	-------	------	-------