

Customer

Technical data

Single-pump system

Isar MODV1-1CV1-L-1606/EC

Project ID

Untitled project 2025-03-03 22:14:23.954

Project name

Installation location

Customer pos. No.

Date 2025-03-03

Duty chart

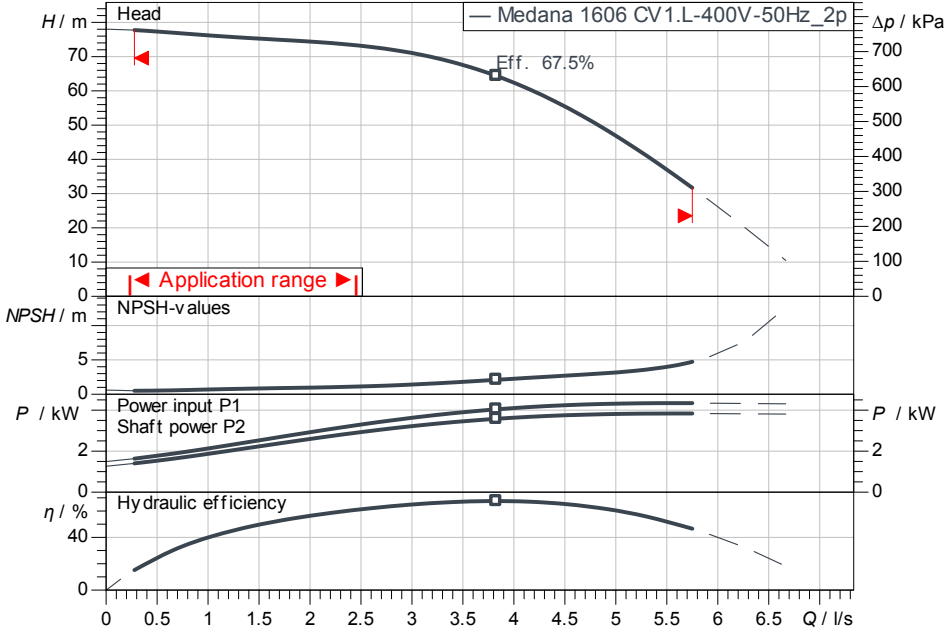

Requested data

Flow	
Head	
Media	Water 100 %
Fluid temperature	20.00 °C
Density	998.30 kg/m ³
Kin. viscosity	1.00 mm ² /s

Hydraulic data (Duty point)

Flow	
Head	
Shaft power P2	

Product data

Single-pump system	
Isar MODV1-1CV1-L-1606/EC	
Control	Without frequency conversion
No. of pumps	1
Max. operating pressure	1,600 kPa
Inlet pressure max.	6 bar
Fluid temperature	3 °C ... +60 °C
Max. ambient temperature	40 °C
Protection class motor	IP55
Protection class of switchgear	IP54
Diaphragm pressure vessel	Yes
Low-water cut-out switchgear	

Motordata per Motor/Pump

Motor efficiency level	IE3
Mains connection	3~ 400 V / 50 Hz
Permitted voltage tolerance	+/-10 %
Max. speed	2,900 1/min
Rated power P2	4.20 kW
Rated current	7.80 A

Efficiency	
50% / 75% / 100%	88.2/88.8/88.3%
Insulation class	F
Motor protection	Yes

Fitting dimensions

Pipe connection on the suction side	Rp 2, PN 10
Pipe connection (pressure side)	R 1½, PN 16

Materials

Pump housing	1.4301
Impeller	1.4301
Shaft	1.4301
Shaft seal	BQ1E3GG
Gasket material	EPDM
Pipework material	1.4307

Information for order placements

Weight approx.	79 kg
Item number	2554113

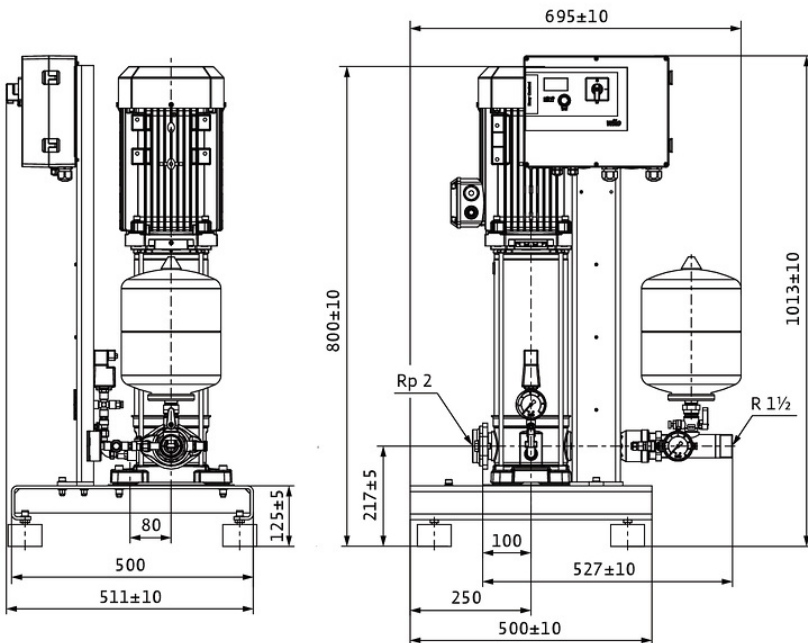

Dimensions mm

Contact
E-mail
Phone

Customer

Contact
E-mail
Phone

Dimensions

Single-pump system
Isar MODV1-1CV1-L-1606/EC

Project ID Untitled project 2025-03-03 22:14:23.954

Project name
Installation location
Customer pos. No.

Date 2025-03-03

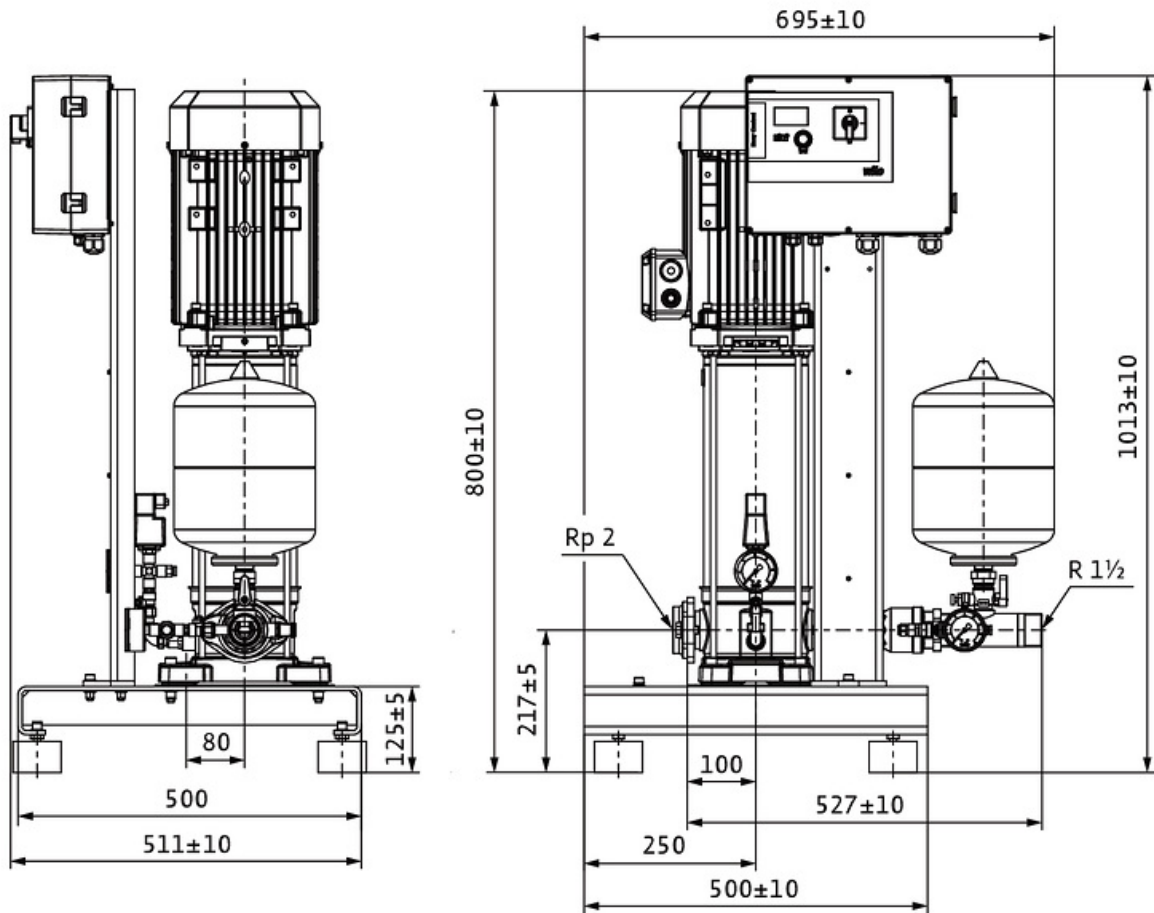

Standard

Suction side Rp 2, PN 10/PN 16
Discharge side R 1½, PN 10/PN 16

Dimensions mm

Name	Value	Name	Value	Name	Value	Name	Value
------	-------	------	-------	------	-------	------	-------