



Contact
E-mail
Phone

Customer

Contact
E-mail
Phone

Technical data

KS 37ZM With motor F 17.1-2/8

Project ID Untitled project 2025-03-05 07:27:14.016
Project name
Installation location
Customer pos. No.

Date 2025-03-05

Pump

Pump type	KS 37ZM
Installation type	Transportable
Free passage	6 mm
Nominal speed	3480
Rated frequency	60 Hz
Impeller type	Multi-channel
Impeller construction	Closed

Impeller Ø

max. possible	135 mm
min. possible	135 mm
standard	135
designed	135 mm

Suction port

Rated diameter	
Pressure rating	
Standard	

Discharge port

Rated diameter	G4
Pressure rating	PN10
Standard	EMU-D

Weights

Weight	max. 9 kg
Weight of motor	47 kg
Weight of unit	max. 56 kg

Materials

Pump housing	EN-GJL-250
Stationary wear ring	EN-GJS-500-7
Impeller	EN-GJS-500-7
Motor housing	G-Al Si12

Motor

Motor name	F 17.1-2/8
Number of poles	2
Rated power	5 kW
Rated speed	3432 1/min
Power input with rated power	6.4 kW
Rated voltage	380 ~3 Y/D V
Current input with rated power	11.1 A
Efficiency with rated power	78 %
cos phi with rated power	0.88
cos phi with starting	0
Rated frequency	60 Hz
Operation type wet	S1
Operation type dry	S1
Starting current, direct starting	68 A
Starting current, star-delta	22.7 A
Starting torque	
Inertia moment	0.0041 kg m ²
Degree of protection	IP 68
Sel. explosion protection	
Ex-designation	
Ex-number	
Motor connection cable	7x1,5 NSSHÖU
Max. fluid temperature	40 °C
Starts per hour max.	15

Duty point data

Volume flow	
Head	
Shaft power P ₂	
Hydr. efficiency η _{hyd.}	
Power input P ₁	
Fluid	Water
Required pump NPSH	
Rotational speed	3,463 1/min
Total efficiency	$= \frac{P_2 * \text{Hydr. efficiency } \eta_{\text{hyd.}}}{P_1}$

Weights

Submersible contractor's pump as single stage block unit for stationary, vertical installation, for pumping muddy water which does not attack the pump materials neither chemically nor mechanically.

Service friendly design of the unit by separate pump and motor.

Pumping values to be guaranteed according to ISO 9906 Annex A

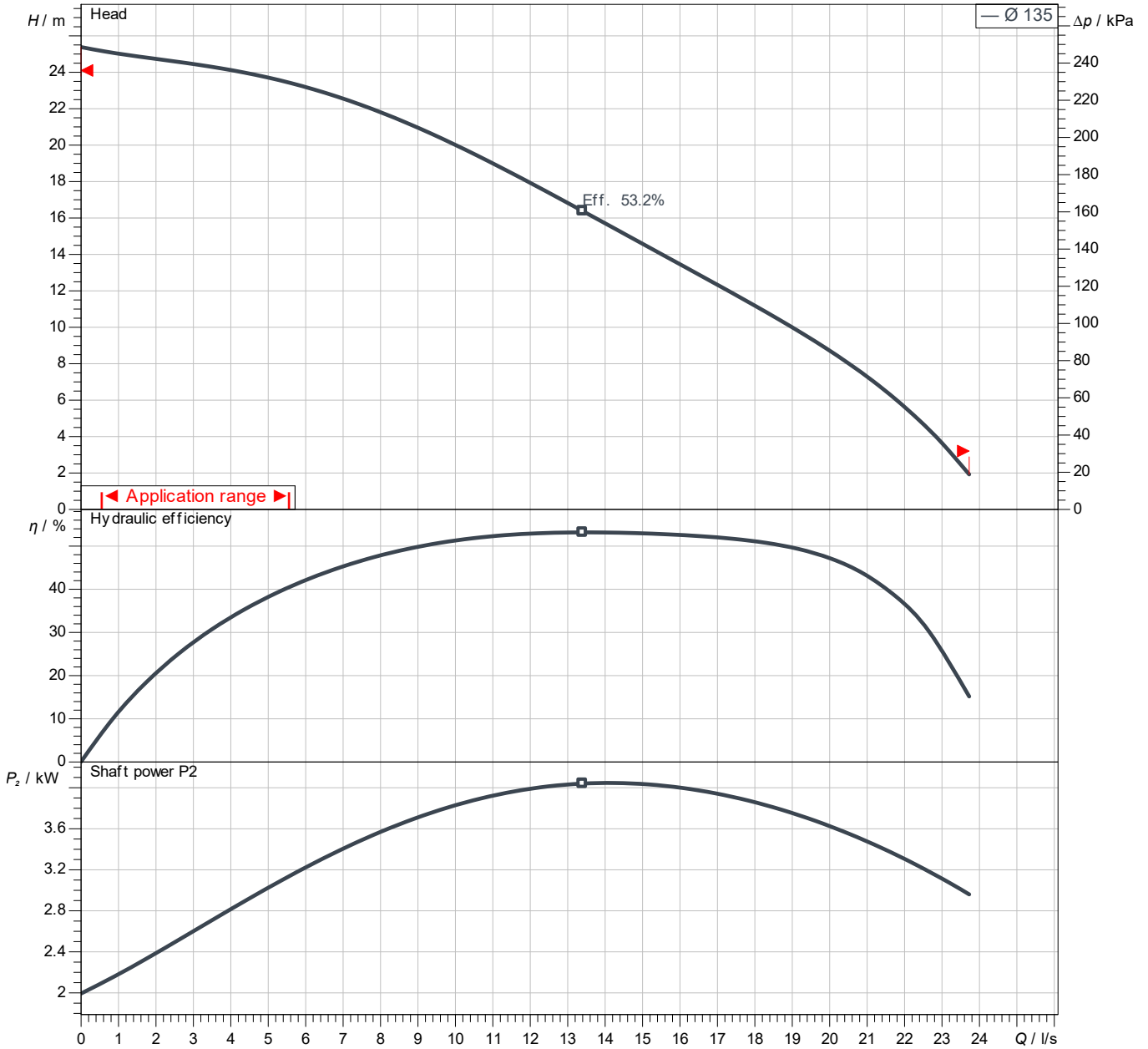

Power data referred to: Water; 20°C; 998.3kg/m³; 1.005mm²/s
Tolerance as per ISO 9906 / Annex A.2

Pump

Impeller Ø	designed	135 mm
Nominal speed		3,432 1/min
Frequency		60 Hz
Impeller type		Multi-channel

Motor

Rated power	5 kW
Sel. explosion protection	

Duty point data

Volume flow	
Head	
Shaft power P ₂	
Hydr. efficiency η hyd.	
Power input P ₁	
Required pump NPSH	
Rotational speed	3463 1/min

Contact
E-mail
Phone

Customer

Contact
E-mail
Phone

Dimensions

KS 37ZM
With motor
F 17.1-2/8

Project ID Untitled project 2025-03-05 07:27:14.016
Project name
Installation location
Customer pos. No.

Date 2025-03-05

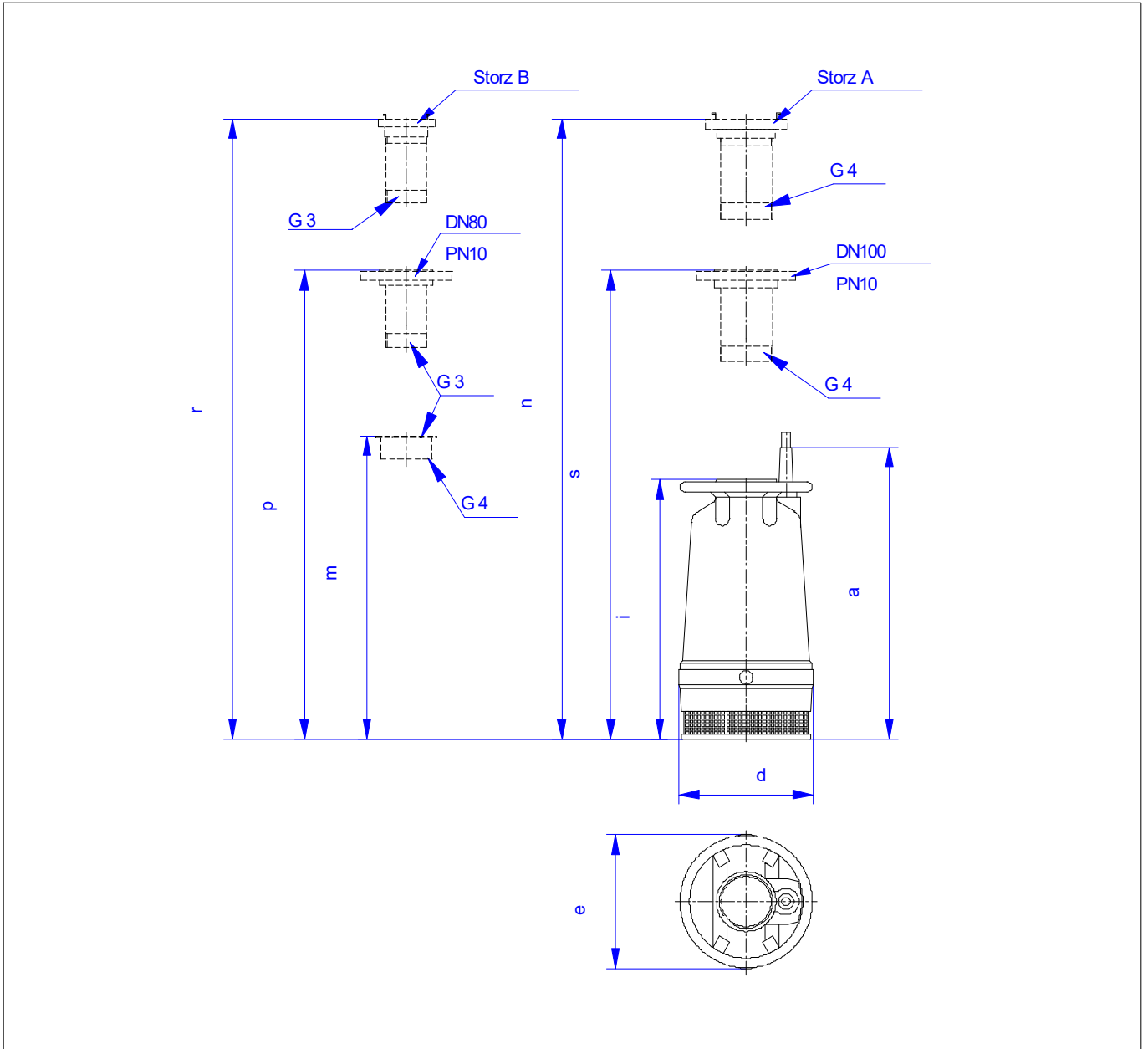

Dimensions

Name	Value	Name	Value
a	644 mm		
d	295 mm		
e	295 mm		
i	573 mm		
m	588 mm		
n	758 mm		
p	712 mm		
r	730 mm		
s	739 mm		

Connections

Suction port	
Discharge port	G4 PN10