

Customer

Technical data

Fire-extinguishing system FLA-2 MVI 7003/1 PN10

Project ID Untitled project 2025-03-03 14:15:38.327

Project name
Installation location
Customer pos. No.

Date 2025-03-03

Duty chart

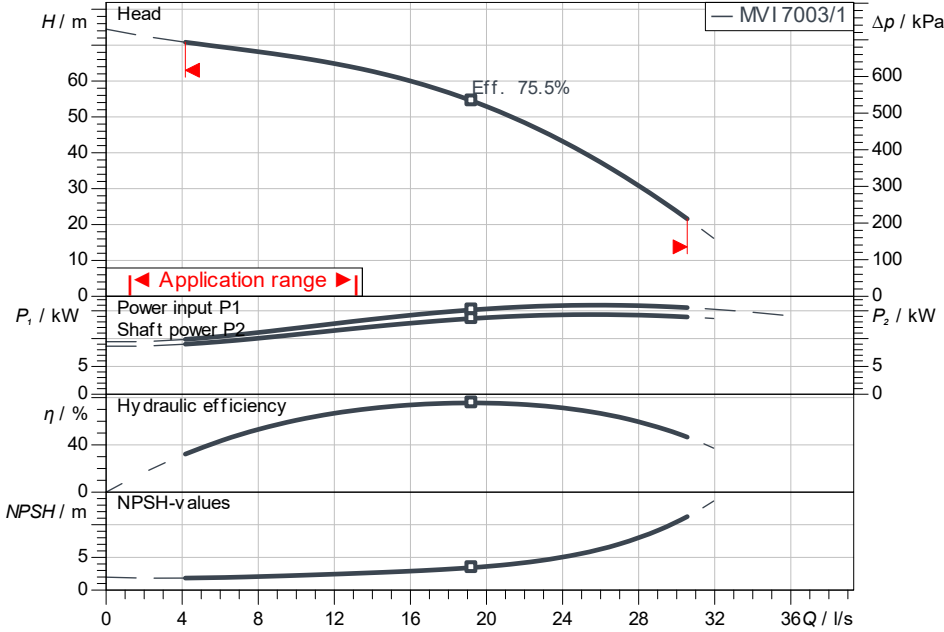

Requested data

Flow
Head
Media Water 100 %
Fluid temperature 20.00 °C
Density 998.30 kg/m³
Kin. viscosity 1.00 mm²/s

Hydraulic data (Duty point)

Flow
Head
Shaft power P2

Product data

Fire-extinguishing system
FLA-2 MVI 7003/1 PN10

No. of pumps 2
Max. operating pressure 1,000 kPa
Inlet pressure max. 1,000
Fluid temperature 3 °C ... +50 °C
Max. ambient temperature 40 °C
Protection class system IP55
Protection class of switchgear IP54
Diaphragm pressure vessel Yes
Low-water cut-out switchgear No

Motordata per Motor/Pump

Motor efficiency level IE3
Mains connection 3~ 400 V / 50 Hz
Permitted voltage tolerance +-10 %
Rated speed 2,900 1/min
Rated power P2 15.00 kW
Rated current 26.70 A
Power factor 0.88
Efficiency 50% / 75% / 100%
Degree of protection IP55
Insulation class F
Motor protection Yes

Fitting dimensions

Pipe connection on the suction side DN 125, PN 10
Pipe connection (pressure side) DN 125, PN 16

Materials

Pump housing 5.1301/EN-GJL-250
Impeller 1.4301
Shaft 1.4057
Shaft seal U3BE3GG
Gasket material EPDM
Pipework material 1.4307

Information for order placements

Weight approx. 824 kg
Item number 2536593

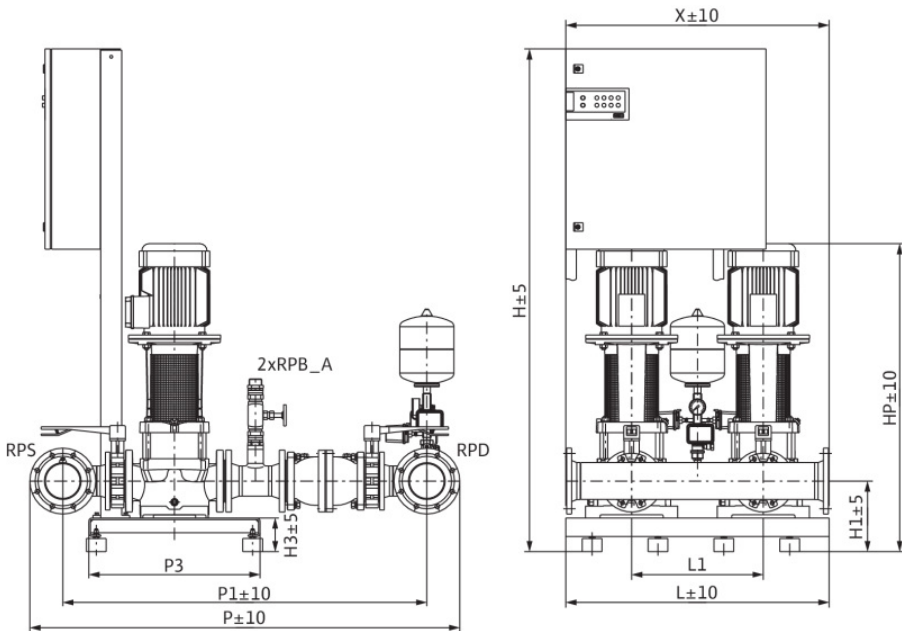

Dimensions

Dimensions		mm			
H	1,905	L	1,000	P4	0
H1	270	L1	500	RPB_A	R 1 1/2
H3	130	P	1,606	RPD	DN 125,
HP	1,448	P1	1,356	RPS	DN 125,
HS	760	P3	650		

