

Customer

Technical data

Glanded standard twin-head pump Atmos GIGA-D 80/120-7,5/2

Project ID Untitled project 2025-03-01 18:38:40.590

Project name
Installation location
Customer pos. No.

Date 2025-03-01

Duty chart

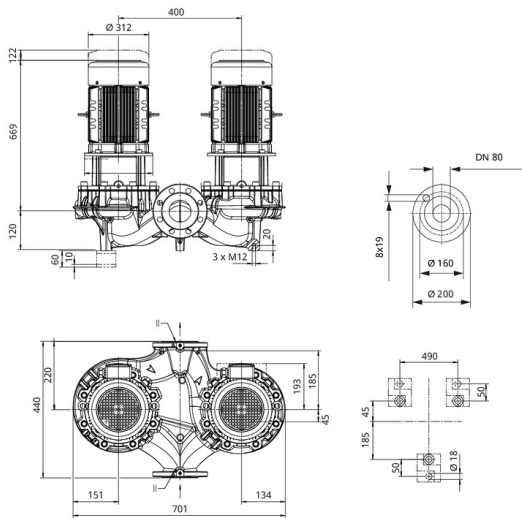
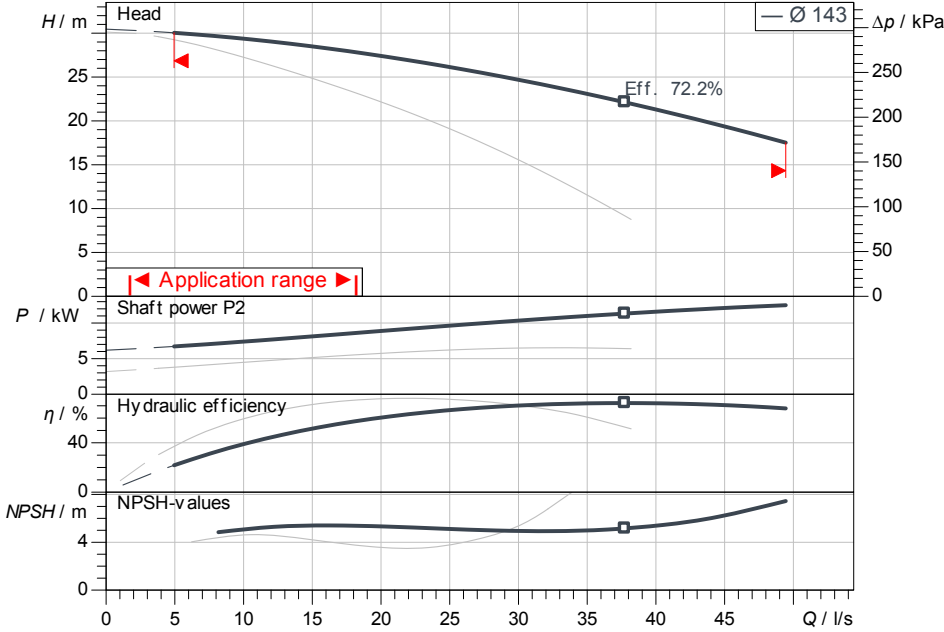

Requested data

Flow	
Head	
Media	Water 100 %
Fluid temperature	20.00 °C
Density	998.30 kg/m ³
Kin. viscosity	1.00 mm ² /s

Hydraulic data (Duty point)

Flow	
Head	
Shaft power P2	
Hydraulic efficiency	
NPSH	

Product data

Glanded standard twin-head pump Atmos GIGA-D 80/120-7,5/2	
Max. operating pressure	1,600 kPa
Fluid temperature	-20 °C ... +140 °C
Max. ambient temperature	40 °C
Minimum efficiency index (MEI)	≥ 0.4

Motordata per Motor/Pump

Motor efficiency level	IE3
Mains connection	3~ 400 V / 50 Hz
Permitted voltage tolerance	+/- 10 %
Rated speed	2,900 1/min
Rated power P2	7.50 kW
Rated current	14.65 A
Power factor	0.9
Efficiency	
50% / 75% / 100%	88.9/ 90.3/90.1%
Degree of protection	IP55
Insulation class	F
Motor protection	PTC integrated

Fitting dimensions

Pipe connection on the suction side	DN 80, PN 16
Pipe connection (pressure side)	DN 80, PN 16
Port to Port	440 mm

Materials

Pump housing	5.1301, EN-GJL-250 cataphoretic-coated
Impeller	EN-GJL-200
Lantern	5.1301/EN-GJL-250
Shaft	1.4122
Shaft seal	AQ1EGG

Information for order placements

Weight approx.	242 kg
Item number	2225432

