

Customer

Technical data

Submersible pump Sub TWI 6.18-40-C

Project ID Untitled project 2025-03-17 07:24:04.380

Project name
Installation location
Customer pos. No.

Date 2025-03-17

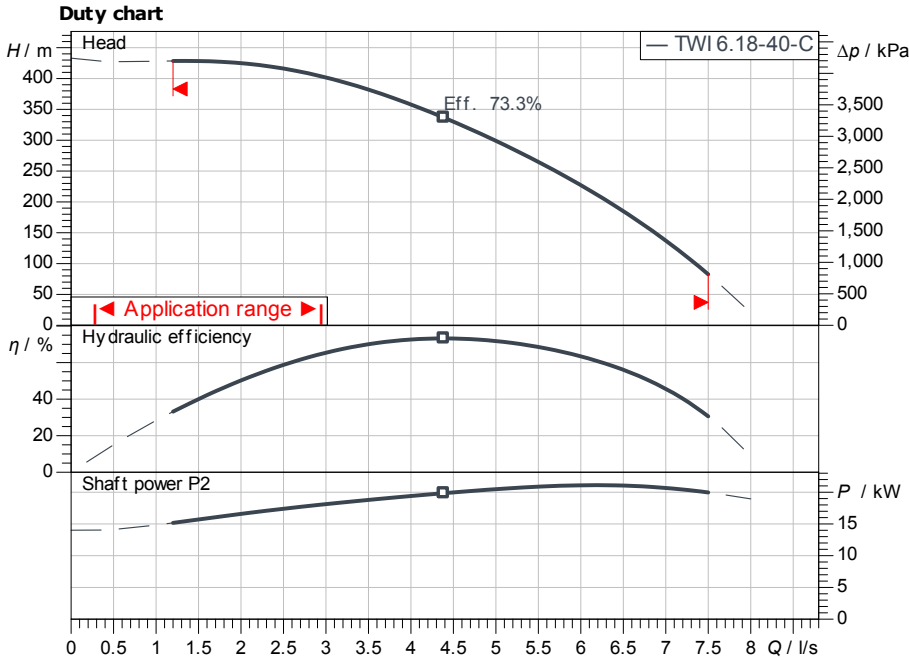

Requested data

Flow
Head
Media Water 100 %
Fluid temperature 20.00 °C
Density 998.30 kg/m³
Kin. viscosity 1.00 mm²/s

Hydraulic data (Duty point)

Flow
Head
Shaft power P_2
Hydraulic efficiency
Power input P_1

Product data

Submersible pump
Sub TWI 6.18-40-C
Max. operating pressure
Fluid temperature 3 °C ... +30 °C
Minimum efficiency index (MEI) ≥ 0.4
Max. pump diameter 142 mm

Motordata per Motor/Pump

Mains connection 3~400 V / 50 Hz
Type of motor Submersible motor

Activation type Direct On Line (DOL)
Min. flow at the motor 0.1 m/s
Motor diameter 136.7 mm
Permitted voltage tolerance +5 %
Nominal speed 2,860 1/min
Rated power P_2 22.00 kW
Rated current 45.30 A
Power factor 0.86
Degree of protection IP68
Insulation class F

Cable

Length of connecting cable 4 m
Cable type 4G4

Fitting dimensions

Discharge size
Flange standard

Materials

Information for order placements

Weight approx. 131 kg
Item number

Approval

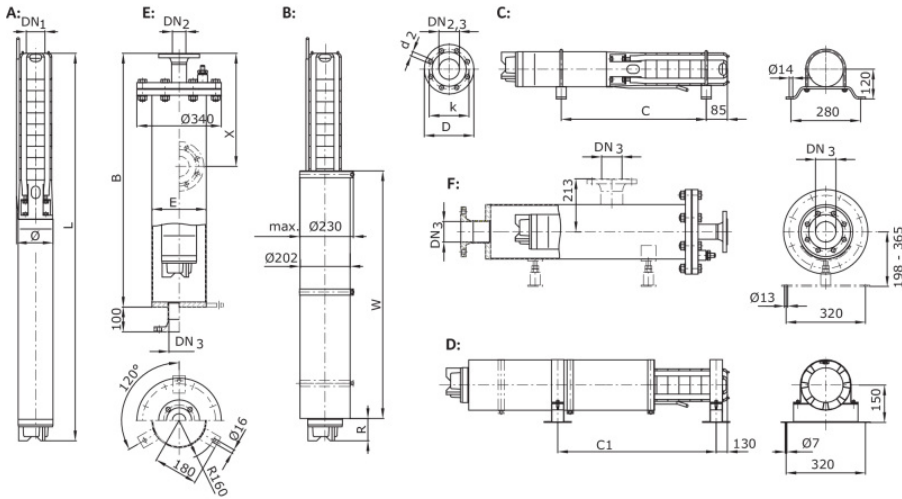

Dimensions

Dimensions		mm	
B	1	W	1,000
c	1		
C1	3,051		
L	3,609		