

Customer

Technical data

Glanded standard pump Atmos GIGA-NHT 50/160-4/2-S2

Project ID Untitled project 2025-03-01 20:45:47.557

Project name
Installation location
Customer pos. No.

Date 2025-03-01

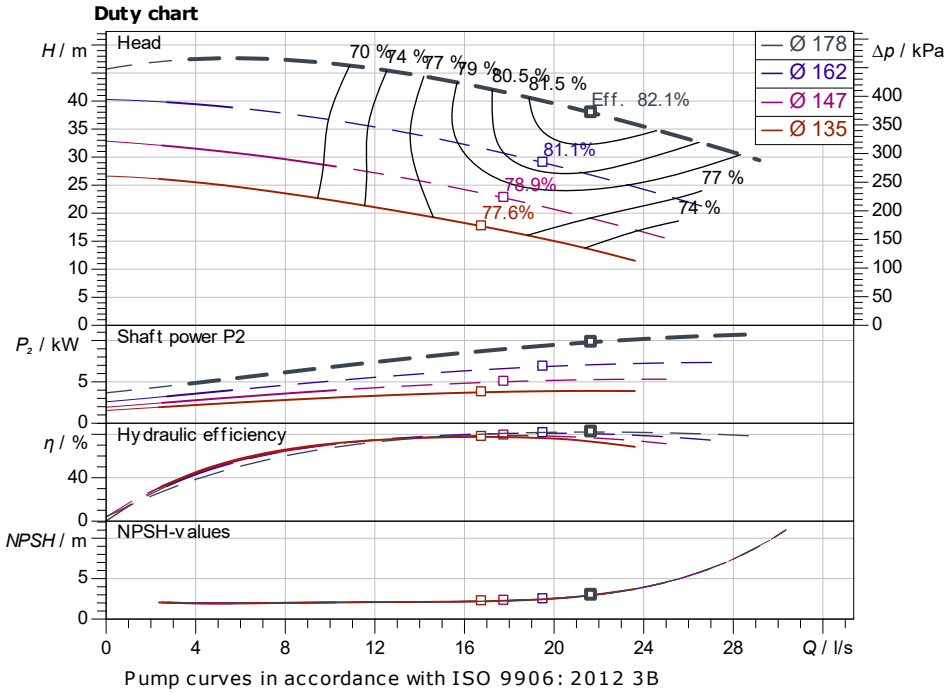

Requested data

Flow	
Head	
Media	Water 100 %
Fluid temperature	20.00 °C
Density	998.30 kg/m ³
Kin. viscosity	1.00 mm ² /s

Hydraulic data (Duty point)

Flow	
Head	
Shaft power P2	
Hydraulic efficiency	
NPSH	
Impeller size	178

Product data

Glanded standard pump	
Atmos GIGA-NHT 50/160-4/2-S2	
Max. operating pressure	2,500 kPa
Fluid temperature	-20 °C ... +350 °C
Max. ambient temperature	50 °C
Minimum efficiency index (MEI)	

Motordata per Motor/Pump

Motor efficiency level	IE3
Mains connection	3~ 400 V / 50 Hz
Permitted voltage tolerance	+10 %
Max. speed	2,900 1/min
Rated power P2	4.00 kW
Rated current	7.59 A
Power factor	0.8
Efficiency	50% / 75% / 100%
	88/88.4/88.4%
Degree of protection	IP55
Insulation class	F
Motor protection	No

Fitting dimensions

Pipe connection on the suction side	DN 65, PN 25
Pipe connection (pressure side)	DN 50, PN 25
Port to Port	

Materials

Pump housing	EN-GJS-400-15
Impeller	EN-GJL-200
Shaft	1.4028
Shaft seal	AQ1VGG

Information for order placements

Weight approx.	
Item number	6098301

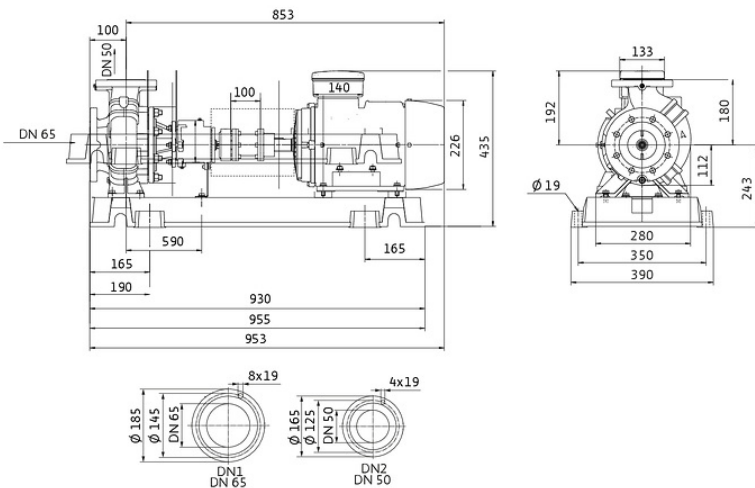

Dimensions mm

Hydraulic data

Glanded standard pump
Atmos GIGA-NHT 50/160-4/2-S2

Project ID: Untitled project 2025-03-01 20:45:47.557

Project name
Installation location
Customer pos. No.

Date: 2025-03-01

Operating data

Rotational speed 2955 1/min	Frequency 50 Hz	Duty point Q =	H =	Suction port DN 65	Discharge port DN 50
---------------------------------------	---------------------------	--------------------------	------------	------------------------------	--------------------------------

Power data referred to: Water; 20°C; 998.3kg/m³; 1.005mm²/s ±10 % tolerance with linear U/f frequency control

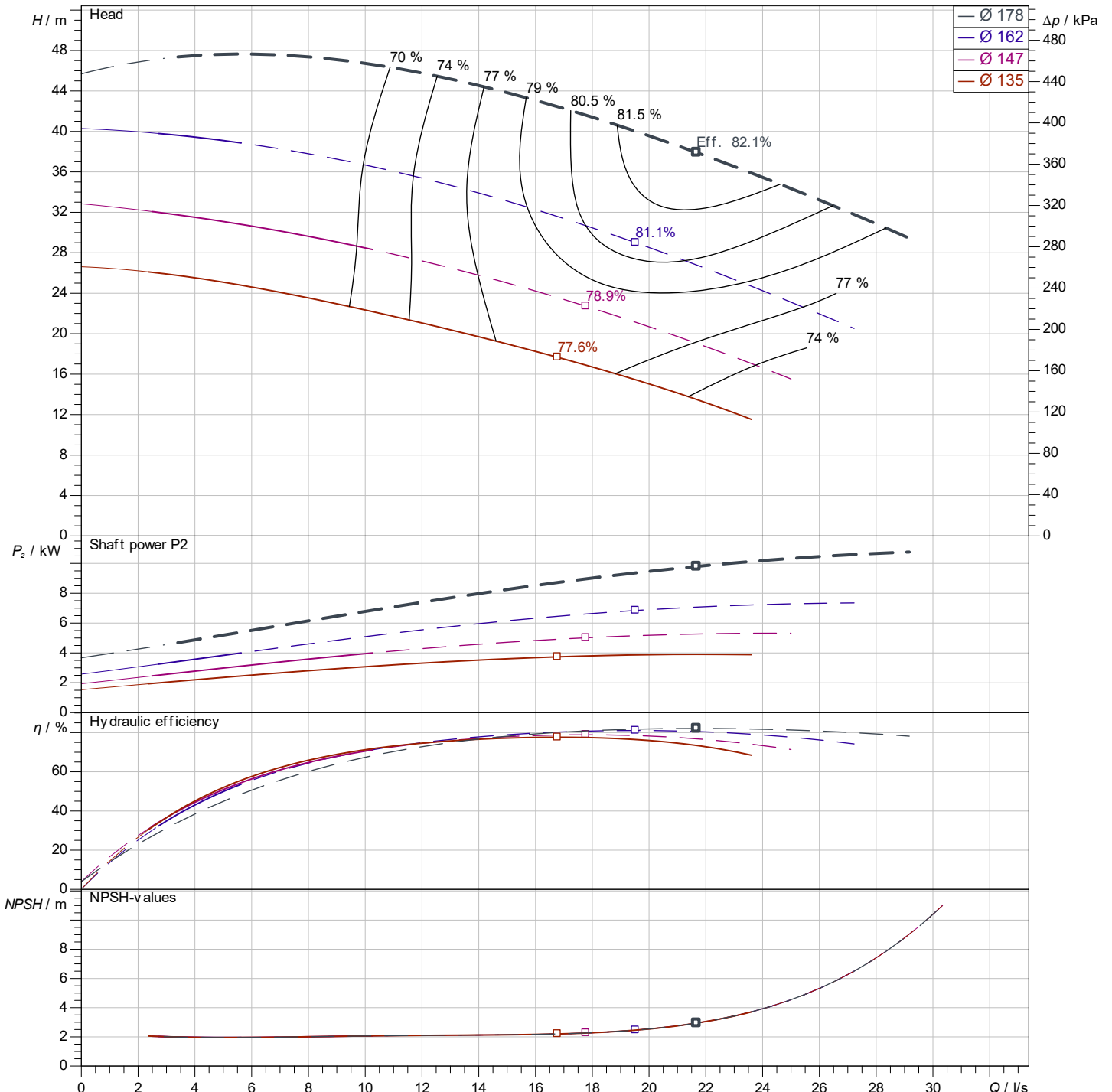

Pump curves in accordance with ISO 9906: 2012 3B

Contact
E-mail
Phone

Customer

Contact
E-mail
Phone

Dimensions

Glanded standard pump
Atmos GIGA-NHT 50/160-4/2-S2

Project ID Untitled project 2025-03-01 20:45:47.557

Project name
Installation location
Customer pos. No.

Date 2025-03-01

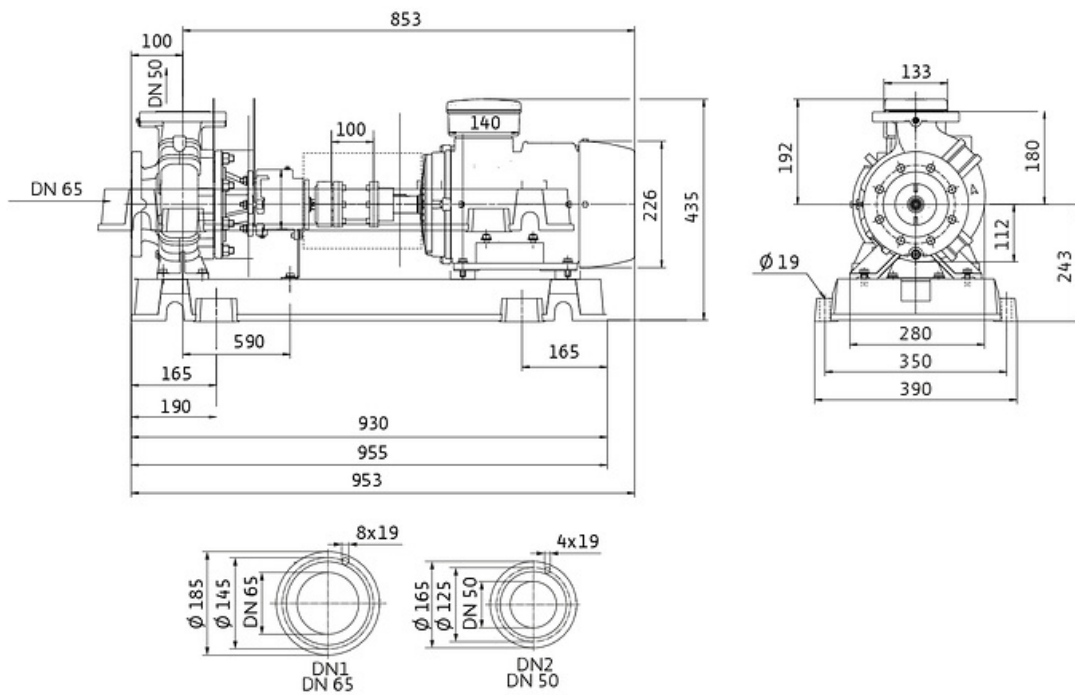

Standard

Suction side DN 65, PN 25
Discharge side DN 50, PN 25

Dimensions mm

Name	Value	Name	Value	Name	Value	Name	Value
------	-------	------	-------	------	-------	------	-------