

Customer

Technical data

High-pressure multistage centrifugal pump MVI 7004-3/16/E/3-400-50-2

Project ID Untitled project 2025-03-03 23:00:00.495

Project name
Installation location
Customer pos. No.

Date 2025-03-03

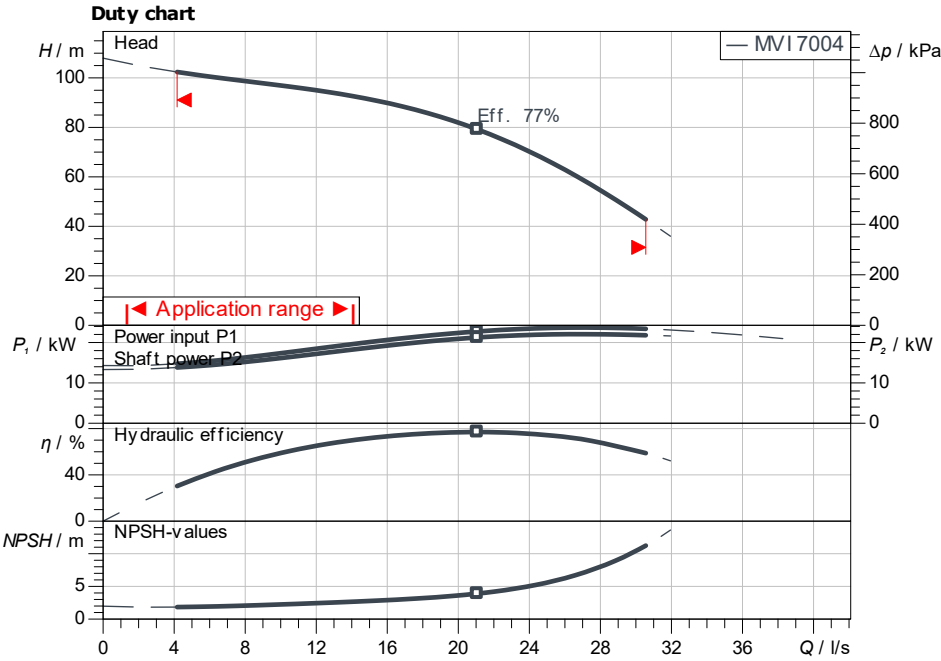

ISO 9906: 2012 3B

Dimensions

H	1,39
H2	927
$\varnothing M$	305
X	218
X	200

mm

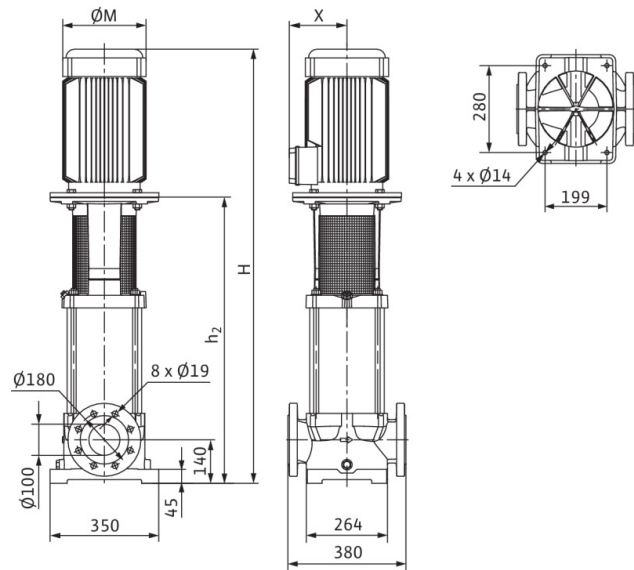

Requested data

Flow	
Head	
Media	Water 100 %
Fluid temperature	20.00 °C
Density	998.30 kg/m ³
Kin. viscosity	1.00 mm ² /s

Hydraulic data (Duty point)

Flow	
Head	
Shaft power P_2	
Hydraulic efficiency	
NPSH	

Product data

High-pressure multistage centrifugal pump MVI 7004-3/16/E/3-400-50-2	
Max. operating pressure	1,600 kPa
Inlet pressure max.	10 bar
Fluid temperature	-15 °C ... +120 °C
Max. ambient temperature	50 °C
Minimum efficiency index (MEI)	≥ 0.4

Motordata per Motor/Pump

Motor efficiency level	IE3
Mains connection	3~ 400 V / 50 Hz
Permitted voltage tolerance	+10 %
Max. speed	2,940 1/min
Rated power P_2	22.00 kW
Rated current	39.10 A
Power factor	0.87
Service factor	1.15
Efficiency	50% / 75% / 100%
Degree of protection	IP55
Insulation class	F
Motor protection	No

Fitting dimensions

Pipe connection on the suction side	DN 100, PN 16
Pipe connection (pressure side)	DN 100, PN 16

Materials

Pump housing	5.1301/EN-GJL-250
Impeller	1.4408
Shaft	1.4057
Shaft seal	U3BE3GG
Gasket material	EPDM

Information for order placements

Weight approx.	213 kg
Item number	4071175