

Customer

Technical data

Sewage lifting unit; Single-pump system DrainLift SANI-S.11/M523/1-EF

Project ID Untitled project 2025-03-30 07:06:50.818

Project name
Installation location
Customer pos. No.

Date 2025-03-30

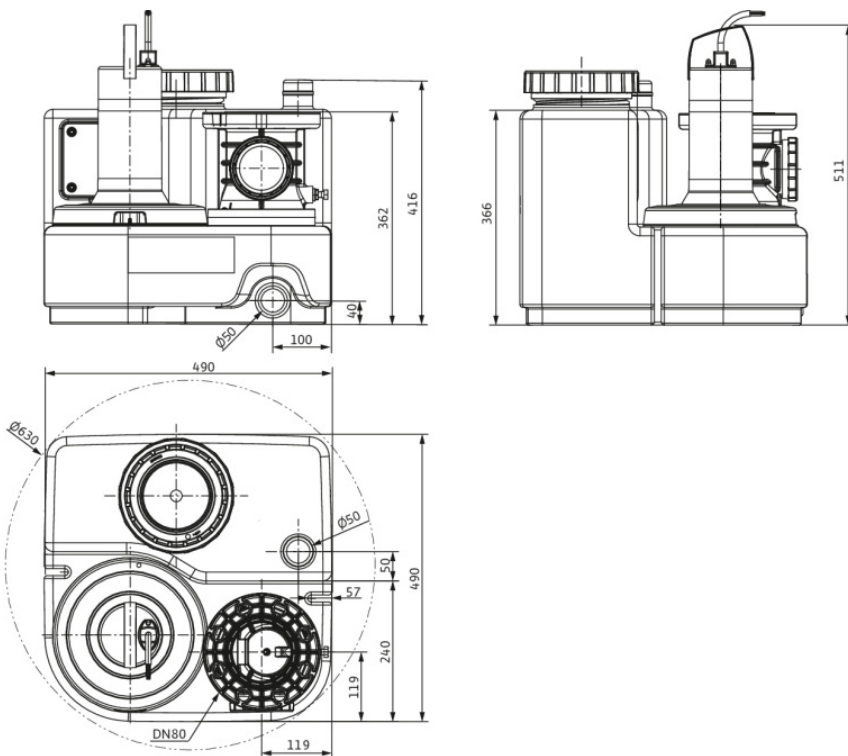
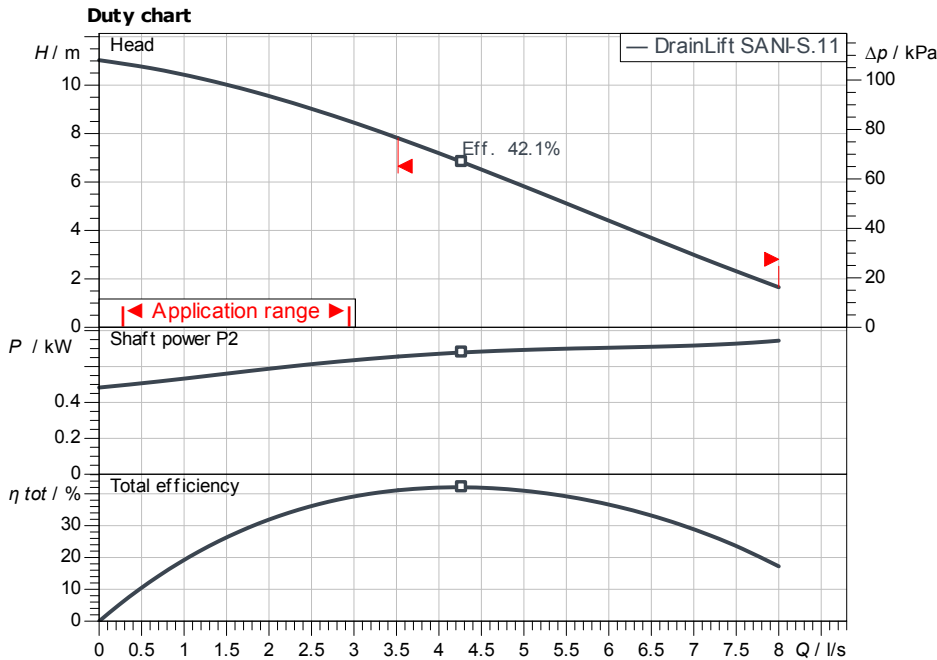

Requested data

Flow	
Head	
Media	Water 100 %
Fluid temperature	20.00 °C
Density	998.30 kg/m ³
Kin. viscosity	1.00 mm ² /s

Hydraulic data (Duty point)

Flow
Head

Product data

Sewage lifting unit; Single-pump system DrainLift SANI-S.11/M523/1-EF	
No. of pumps	1
Max. operating pressure	120 kPa
Fluid temperature	3 °C ... +40 °C
Grinder	No
Operating mode (non-immersed)	S3-10%
Gross volume	47 l
Max. switching volume	25 l
Max. sound pressure level	70 dB
Free ball passage	44 mm

Motordata per Motor/Pump

Mains connection	1~ 230 V / 50 Hz
Permitted voltage tolerance	+10 %
Nominal speed	2,829 1/min
Rated power P2	0.75 kW
Power input P1	1.07 kW
Rated current	5.40 A
Activation type	-
Degree of protection	IP68
Motor protection	Bi металл
Insulation class	F
Schaltspiel	60

Cable

Length of connecting cable	4 m
Mains plug	CEE 7/7 (Schuko)
Type of connection cable	Detachable
Cable type	H07RN-F
Cable cross section	3G1

Fitting dimensions

Venting	DN 50 (50 mm)
Pipe connection on the suction side	DN 110 (110 mm)
Pipe connection (pressure side)	DN 80

Materials

Tank	PE
Pump housing	PP-GF30
Impeller	PP-GF30
Shaft	1.4401
Motor housing	1.4301
Gasket material	NBR

Information for order placements

Weight approx.	27 kg
Item number	6098869

