

**Customer**

## Technical data

### Sewage lifting unit; Double-pump system DrainLift SANI-XL.19/T540/4-CEE

Project ID                      Untitled project 2025-03-30 07:06:50.818

Project name  
Installation location  
Customer pos. No.

Date                      2025-03-30

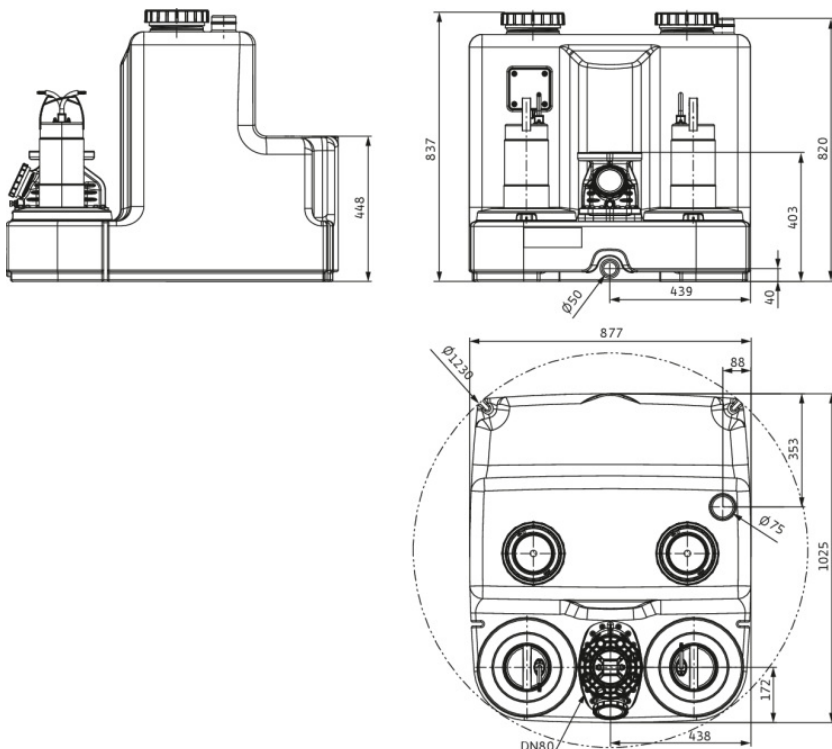
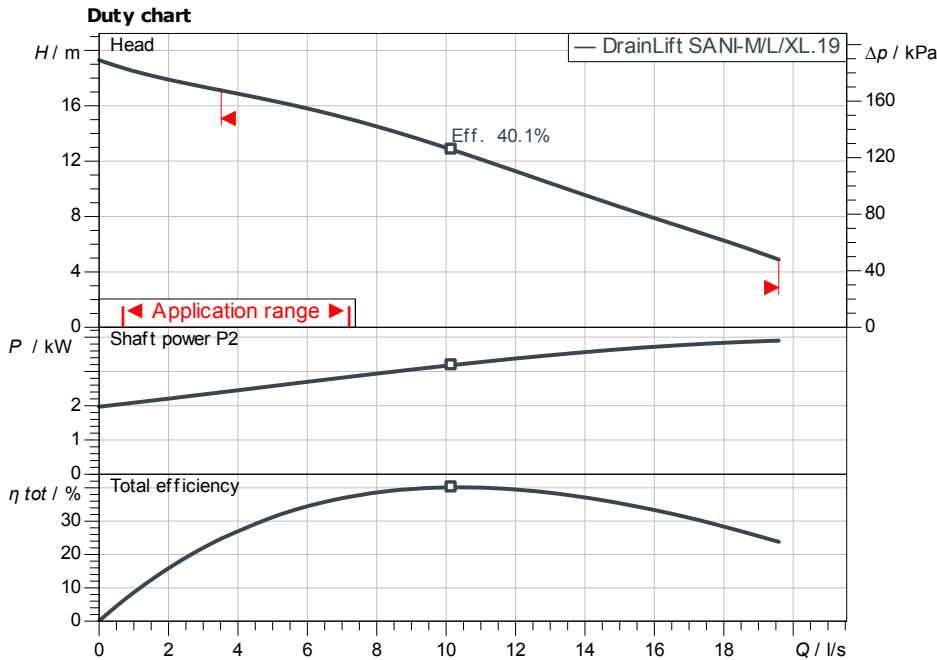

**Requested data**

Flow	
Head	
Media	Water 100 %
Fluid temperature	20.00 °C
Density	998.30 kg/m <sup>3</sup>
Kin. viscosity	1.00 mm <sup>2</sup> /s

**Hydraulic data (Duty point)**

Flow  
Head

**Product data**

Sewage lifting unit; Double-pump system DrainLift SANI-XL.19/T540/4-CEE	
No. of pumps	2
Max. operating pressure	600 kPa
Fluid temperature	3 °C ... +40 °C
Grinder	No
Operating mode (non-immersed)	S1
Gross volume	372 l
Max. switching volume	0 l
Max. sound pressure level	70 dB
Free ball passage	65 mm

**Motordata per Motor/Pump**

Mains connection	3~ 400 V / 50 Hz
Permitted voltage tolerance	+10 %
Nominal speed	2,879 1/min
Rated power P2	3.90 kW
Power input P1	4.8 kW
Rated current	8.50 A
Activation type	Direct On Line (DOL)
Degree of protection	IP68
Motor protection	<b>Bimetal</b>
Insulation class	F
Schaltspiel	60

**Cable**

Length of connecting cable	10 m
Mains plug	CEE 32A, 3P+N+PE, 6P
Type of connection cable	Detachable
Cable type	H07RN-F
Cable cross section	6G1

**Fitting dimensions**

Venting	DN 75 (75 mm)
Pipe connection on the suction side	DN 110 (110 mm)
Pipe connection (pressure side)	DN 80

**Materials**

Tank	PE
Pump housing	PP-GF30
Impeller	1.4408
Shaft	1.4401
Motor housing	1.4401
Gasket material	NBR

**Information for order placements**

Weight approx.	97 kg
Item number	6098877

