

66SV7G11046T/D

Technical data

Company name
Contact
Phone number
e-mail address

Operating data

Pump type	Single head pump	Fluid	Water
Available system NPSH	ft 0	Operating temperature t A	°F 39.2
Nominal flow	US g.p.m. 0	pH-value at t A	7
Nominal head	ft 0	Density at t A	lb/ft ³ 62.4
Static head	ft 0	Kin. viscosity at t A	ft ² /s 1.689E-5
Inlet pressure	psi 0	Vapor pressure at t A	psi 14.5
Environmental temperature	°F 68	Solids	0
		Altitude	ft 0

Pump data

Make	Lowara	Nominal	US g.p.m. ()
Speed	rpm 1750	Flow	Max- US g.p.m. 237.8
Number of stages	7		Min- US g.p.m.
Max. casing pressure	psi	Nominal	ft
Max. working pressure	psi 104.2	Head	at Qmax ft 119.2
Head H(Q=0)	ft 240		at Qmin ft 240.3
Weight	lb 512	Shaft power	hp ()
	Max. inch 5 7/8	Max. shaft power	hp 10.6
Impeller R	designed inch 5 7/8	Efficiency	%
	Min. inch 5 7/8	NPSH 3%	ft

Pump Materials

Pump body	Cast iron
Lower support	Cast iron
Impeller	Stainless steel / AISI 316L
Diffuser	Stainless steel / AISI 304
Outer sleeve	Stainless steel / AISI 304
Shaft	Stainless steel / AISI 431
Adapter	Cast iron
Wear ring	Technopolymer PPS
Coupling	Cast iron
Upper head	Cast iron
SEAL HOUSING	Cast iron
Coupling protection	Stainless steel / AISI 304
Shaft sleeve and bushing	Tungsten carbide
Bushing for diffuser	Carbon
Fill / drain plugs	Stainless steel / AISI 316

Shaft Seal

e-SV Mechanical seal	Roten
e-SV - Uniten (-30 / +120 °C)	
1 - Rotating part	Silicon Carbide
2 - Stationary part	Resin impregnated carbon
3 - Elastomers	EPDM
4 - Springs	AISI 316
5 - Other components	AISI 316

Motor data

Manufacturer	Lowara	Electric voltage	220 V	Speed	1758 rpm	Insulation class	F
Specific design	IE3 3ph Flange Motor - Premium Efficiency	Frame size	160 M	Colour			RAL 5010
Type	PLM 160 B5 11 kW						
Rated power	14.751 hp	Degree of protection	IP55				
Electric current	38.3 A						

Remarks:

66SV7G11046T/D

Performance curve

Company name
Contact
Phone number
e-mail address

Hydraulic data

Operating Data Specification		Hydraulic data (duty point)		Impeller design	
Flow	0 US g.p.m.	Flow		Impeller R	5 7/8 inch
Head	0 ft	Head		Frequency	60 Hz
Static head	0 ft	MEI	---	Speed	1750 rpm

Power datas referred to:
Water [100%] ; 39.2°F; 62.4lb/ft³; 1.69E-5ft²/s
Performance according to ISO 9906:2012 – Grade 3B

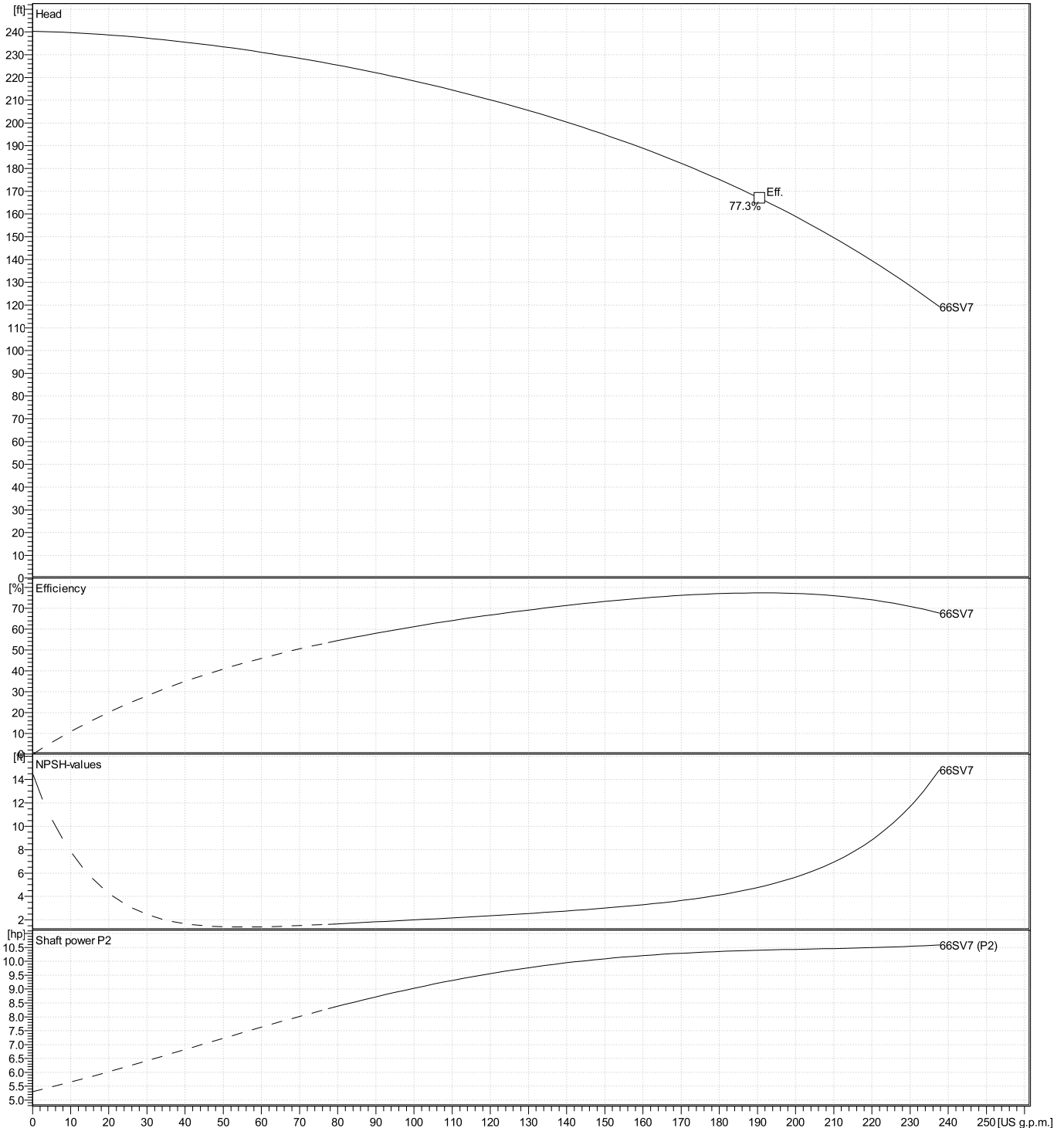

66SV7G11046T/D

Dimensions

Company name
Contact
Phone number
e-mail address

Drawing

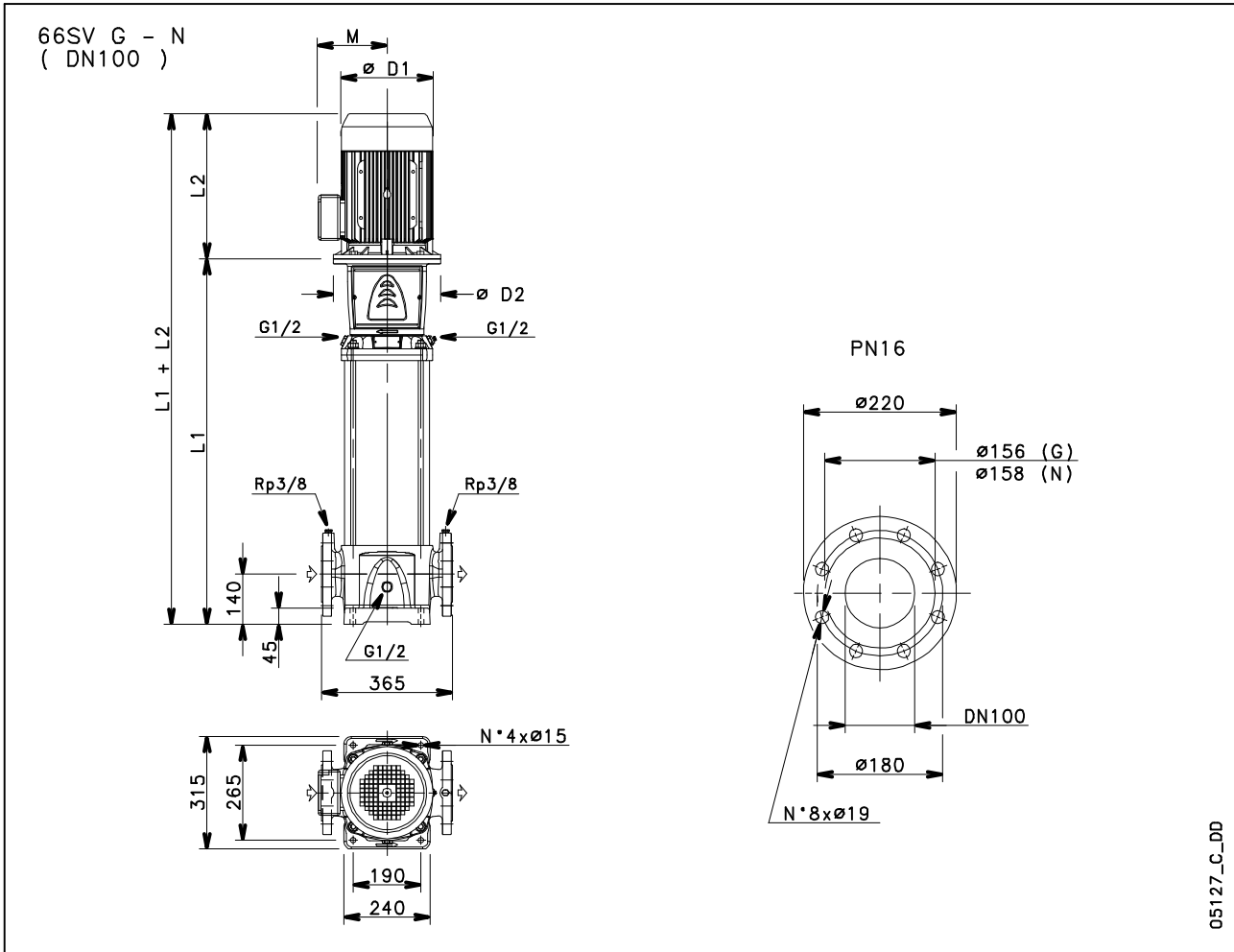

05127_C_DD

Dimensions inch

Electrical and dimensional data refer to IE3 motor

D1	12 ⁵ / ₁₆					Weight 500 lb
D2	13 ³ / ₄					
L1	45 ¹ / ₄					
L2	19 ⁷ / ₁₆					
M	9 ⁷ / ₁₆					