

125SV7G550T/E

Technical data

Company name
Contact
Phone number
e-mail address

Operating data

Pump type	Single head pump	Fluid	Water
Available system NPSH	m 0	Operating temperature t A	°C 4
Nominal flow	m ³ /h 0	pH-value at t A	7
Nominal head	m 0	Density at t A	kg/m ³ 1000
Static head	m 0	Kin. viscosity at t A	mm ² /s 1.569
Inlet pressure	kPa 0	Vapor pressure at t A	kPa 100
Environmental temperature	°C 20	Solids	0
		Altitude	m 0

Pump data

Make	Lowara	Nominal	m ³ /h ()
Speed	rpm 2900	Flow	Max- m ³ /h 160
Number of stages	7		Min- m ³ /h
Max. casing pressure	kPa	Nominal	m
Max. working pressure	kPa 1846.8	Head	at Qmax m 68.6
Head H(Q=0)	m 190		at Qmin m 188.3
Weight	kg 636	Shaft power	kW ()
	Max. mm 145	Max. shaft power	kW 48.9
Impeller R	designed mm 145	Efficiency	%
	Min. mm 145	NPSH 3%	m

Pump Materials

Pump body	Cast iron
Lower support	Stainless steel / AISI 304
Impeller	Stainless steel / AISI 304
Diffuser	Stainless steel / AISI 304
Outer sleeve	Stainless steel / AISI 431
Shaft	Stainless steel / AISI 431
Adapter	Cast Iron
Wear ring	Technopolymer PPS
Coupling	Cast Iron
Upper head	Cast iron
SEAL HOUSING	Cast iron
Coupling protection	Stainless steel / AISI 304
Shaft sleeve and bushing	Tungsten carbide
Bushing for diffuser	Carbon
Fill / drain plugs	Stainless steel / AISI 316

Shaft Seal

e-SV Mechanical seal	Roten
e-SV - Uiten (-30 / +120 °C)	
1 - Rotating part	Silicon Carbide
2 - Stationary part	Resin impregnated carbon
3 - Elastomers	EPDM
4 - Springs	AISI 316
5 - Other components	AISI 316

Motor data

Manufacturer	Lowara	Electric voltage	400 V	Speed	2975 rpm	Insulation class	F
Specific design	IE3 3ph Flange Motor - Premium Efficiency			Frame size	250 S/M	Colour	RAL 5010
Type	3MGS 250 M B5 55 kW						
Rated power	55 kW	Degree of protection IP55					
Electric current	92.5 A						

Remarks:

125SV7G550T/E

Performance curve

Company name
Contact
Phone number
e-mail address

Hydraulic data

Operating Data Specification		Hydraulic data (duty point)		Impeller design	
Flow	0 m ³ /h	Flow		Impeller R	145 mm
Head	0 m	Head		Frequency	50 Hz
Static head	0 m	MEI >=0,7		Speed	2900 rpm

Power datas referred to:

Water [100%] ; 4°C; 1000kg/m³; 1.57mm²/s

Performance according to ISO 9906:2012 – Grade 3B

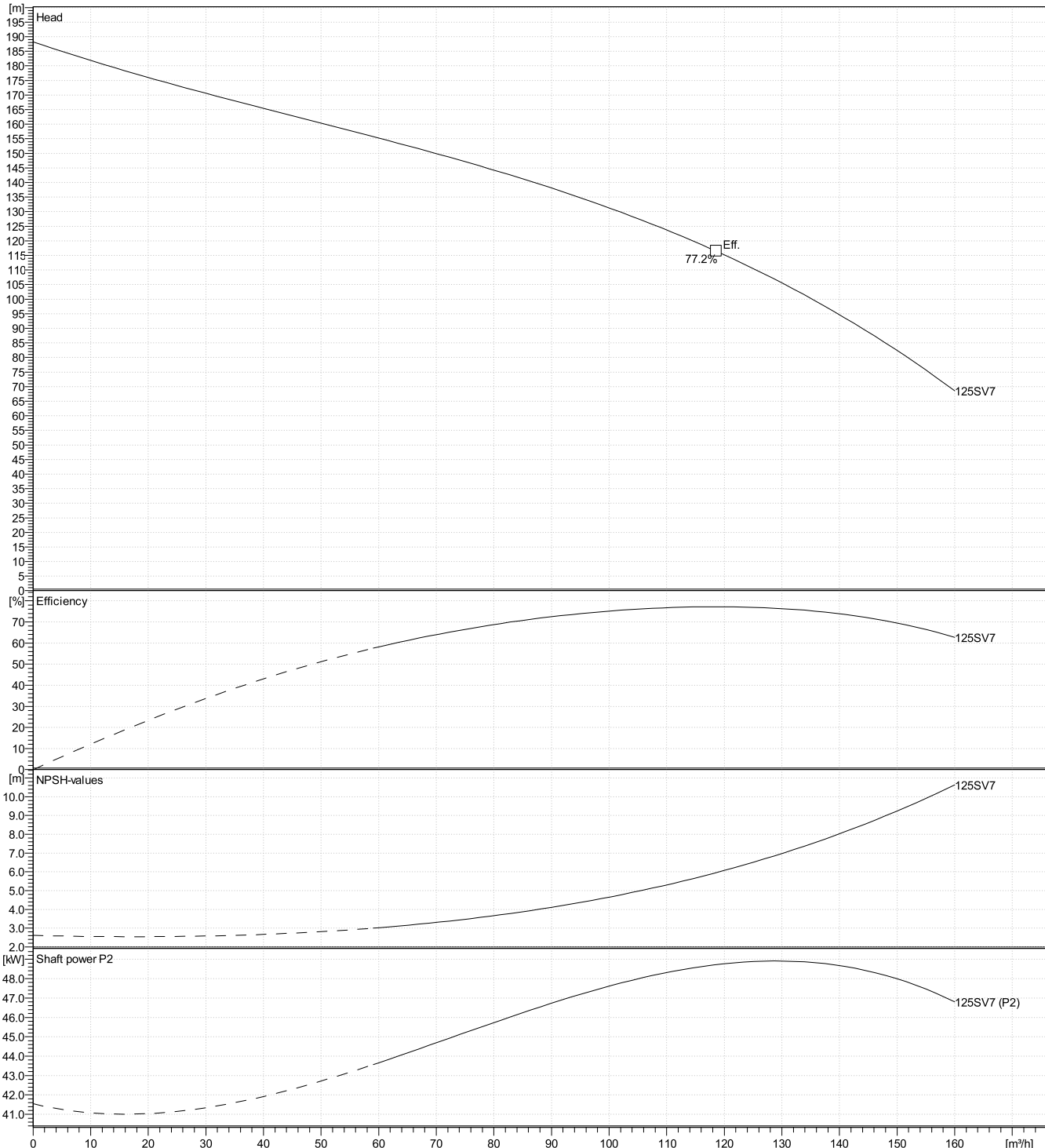

125SV7G550T/E

Dimensions

Company name
Contact
Phone number
e-mail address

Drawing

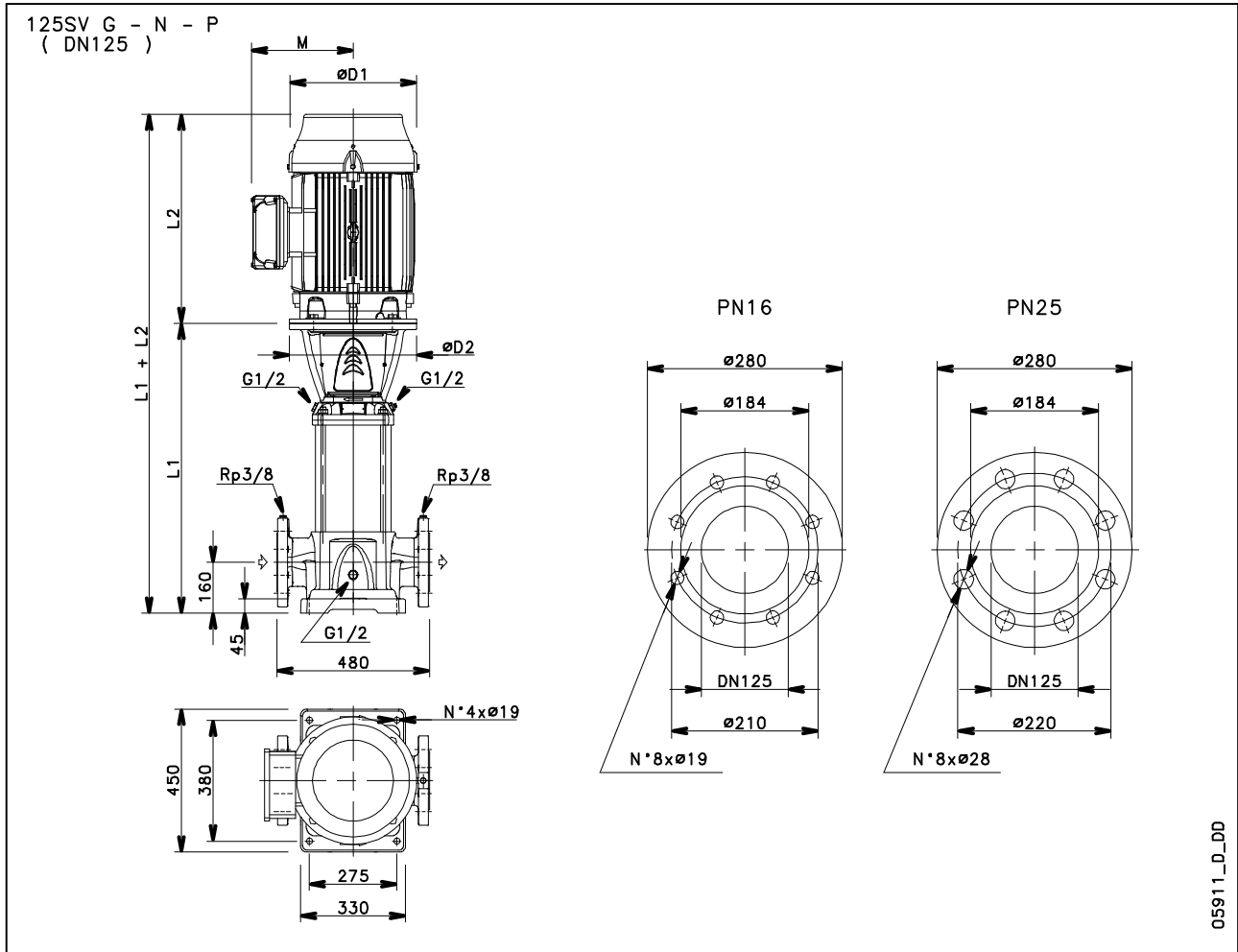

Dimensions mm

Electrical and dimensional data refer to IE3 motor

D1	513					Weight 600 kg
D2	550					
L1	1658					
L2	766.5					
M	377					