

1HM25S11M5HQBE

Technical data

Company name
Contact
Phone number
e-mail address

Operating data

Pump type	Single head pump	Fluid	Water
Available system NPSH	m 0	Operating temperature at t A	°C 4
Nominal flow	m ³ /h 0	pH-value at t A	7
Nominal head	m 0	Density at t A	kg/m ³ 1000
Static head	m 0	Kin. viscosity at t A	mm ² /s 1.569
Inlet pressure	kPa 0	Vapor pressure at t A	kPa 100
Environmental temperature	°C 20	Solids	0
		Altitude	m 0

Pump data

Make	Lowara	Nominal	m ³ /h ()
Speed	rpm 2900	Flow	Max- m ³ /h 2.4
Number of stages	25	Min-	m ³ /h .7
Max. casing pressure	kPa	Nominal	m
Max. working pressure	kPa 1462.9	Head	at Qmax m 67.4
Head H(Q=0)	m 150	at Qmin	m 145.9
Weight	kg 21	Shaft power	kW ()
	Max. mm 73	Max. shaft power	kW 1.1
Impeller R	designed mm 73	Efficiency	%
	Min. mm 73	NPSH 3%	m

Pump Materials

Head	Stainless steel / AISI 304
Impeller	Stainless steel / AISI 304
Diffuser	Stainless steel / AISI 304
Outer sleeve	Stainless steel / AISI 304
Shaft	Stainless steel / AISI 316
Adapter	Aluminium
Ring with foot	Aluminium
SEAL HOUSING	Stainless steel / AISI 304
Shaft sleeve and bushing	Tungsten carbide
Fill / drain plugs	Stainless steel / AISI 316
Tie rods	Stainless steel / AISI 431
Wear ring	Technopolymer

Shaft Seal

e-HM Mechanical seal	Burgmann
e-HM - Burgmann	
1 - Rotating ring	Silicon Carbide
2 - Stationary part	Carbon, resin-impregnated
3 - Elastomers	EPDM
4 - Springs	AISI 316
5 - Other components	AISI 316

Motor data

Manufacturer	Lowara	Electric voltage	221 V	Speed	2860 rpm	Insulation class	F
Specific design	IE2 1ph Flange Motor			Frame size	80	Colour	RAL 5010
Type	SM80HM/111 E2						
Rated power	1.1 kW	Degree of protection	IP55				
Electric current	6.26 A						

Remarks:

1HM25S11M5HQBE

Performance curve

Company name
Contact
Phone number
e-mail address

Hydraulic data

Operating Data Specification		Hydraulic data (duty point)		Impeller design	
Flow	0 m ³ /h	Flow		Impeller R	73 mm
Head	0 m	Head		Frequency	50 Hz
Static head	0 m			Speed	2900 rpm

Power datas referred to:

Water [100%] ; 4°C; 1000kg/m³; 1.57mm²/s

Performance according to ISO 9906:2012 – Grade 3B

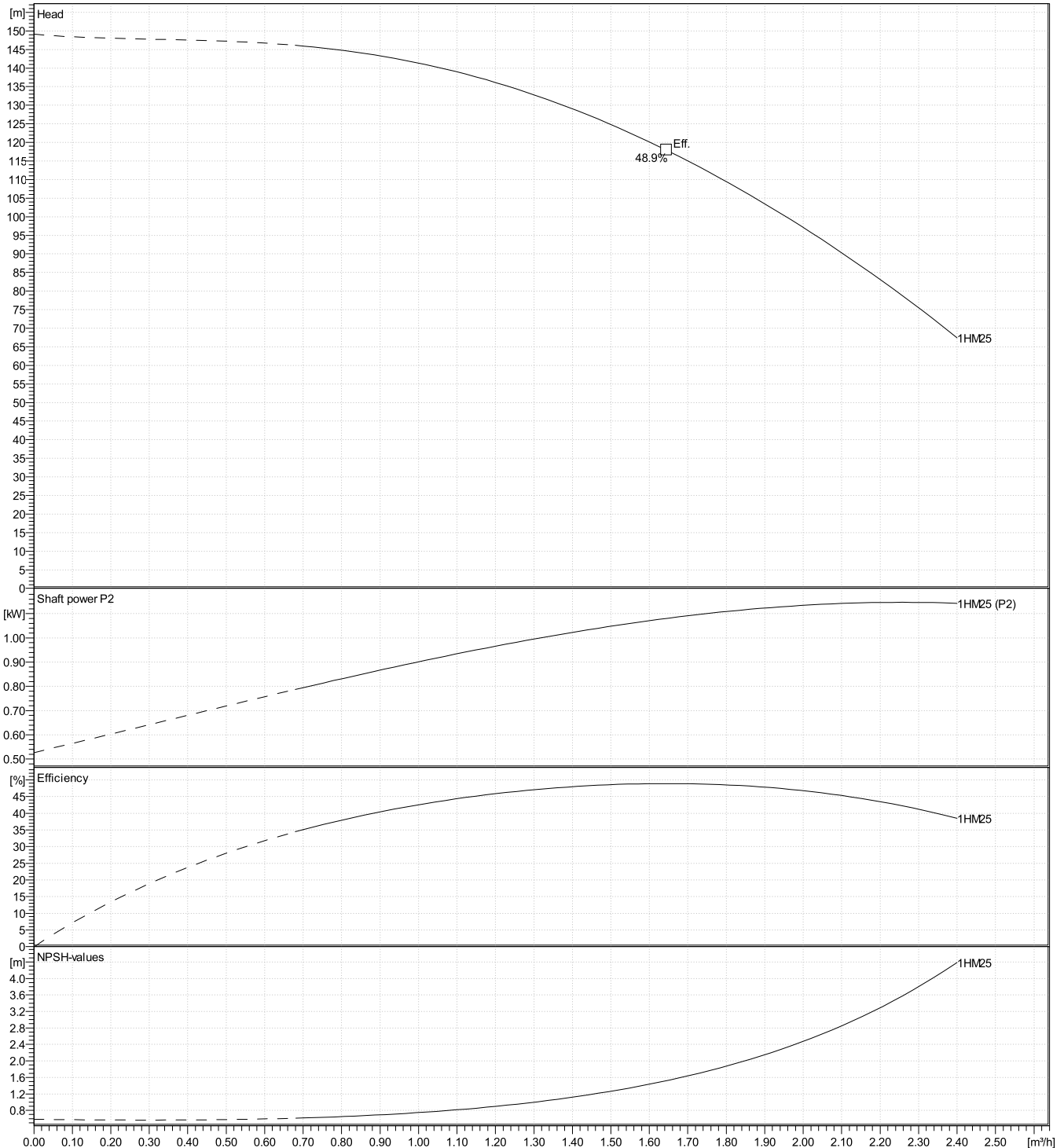

1HM25S11M5HQBE

Dimensions

Company name
Contact
Phone number
e-mail address

Drawing

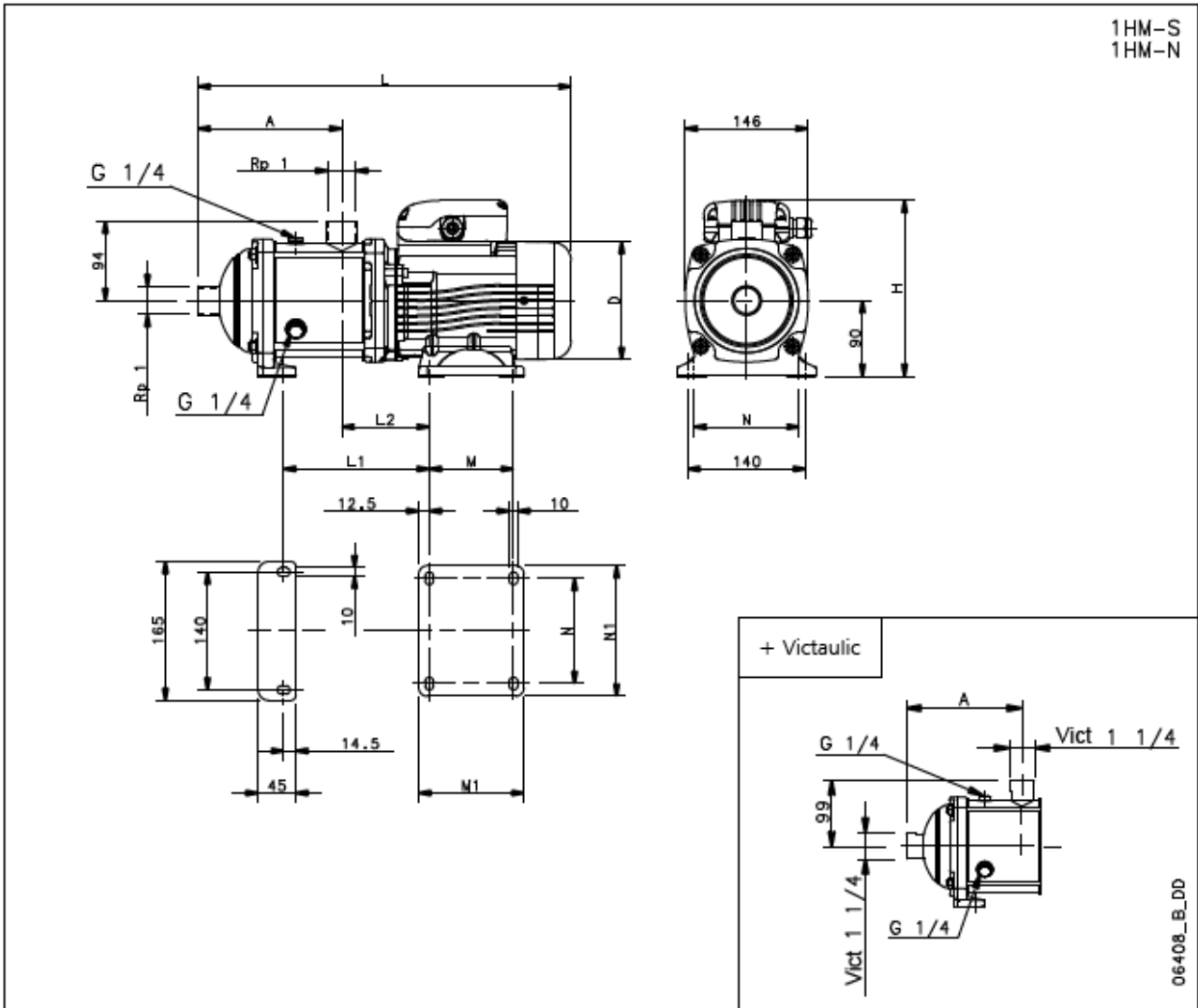

Dimensions mm

A	511	N	125			Weight 20 kg
D	155	N1	155			
H	227	PN	16bar			
L	828					
L1	513					
L2	104					
M	100					