

ESHE 25-200/03/X45RSSA

Technical data

Company name
Contact
Phone number
e-mail address

| Operating data | | | | | | |
|----------------|---------------------------|-------------------|----|--|--------------------|-----------|
| 1 | Pumpe type | Single head pump | | Fluid | Water, pure | |
| 2 | No. of pumps | 1 | | Operating temperature t A | °C | 4 |
| 3 | Nominal flow | m ³ /h | 0 | Max / Min Operating Temperature mech. Seal | °C | 120 / -10 |
| 4 | Nominal head | m | 0 | pH-value at t A | | 7 |
| 5 | Static head | m | 0 | Density at t A | kg/m ³ | 1000 |
| 6 | Inlet pressure | kPa | 0 | Kin. viscosity at t A | mm ² /s | 1.569 |
| 7 | Environmental temperature | °C | 20 | Vapor pressure at t A | kPa | 100 |
| 8 | Available system NPSH | m | 0 | Altitude | | 0 |

| Pump data | | | | | | | | | |
|-----------|-----------------------|------------------------------------|--------|------------|-------------|------------|-------------------|-------------------|-----|
| 9 | Lubrication | Standard, Grease lubrication [Std] | | | | | | | |
| 10 | Execution | | | | | | | | |
| 11 | Design | Horizontal | | Impeller Ø | Max. | mm | 195 | | |
| 12 | Operating speed | 1410 rpm | Stages | | 1 | designed | mm | 178 | |
| 13 | Suction nozzle | DN 50 | / | PN 16 | / | EN1092-1 | Min. | mm | 178 |
| 14 | Discharge nozzle | DN 25 | / | PN 16 | / | EN1092-1 | Nominal | m ³ /h | |
| 15 | Max. casing pressure | kPa | 1200 | | Flow | Max- | m ³ /h | 13.1 | |
| 16 | Max. working pressure | kPa | 87.2 | | | Min- | m ³ /h | 4.4 | |
| 17 | Impeller type | Radial impeller | | Head | Nominal | m | | | |
| 18 | Head H(Q=0) | m | 8.9 | | at Qmax | m | 3.2 | | |
| 19 | Max. shaft power | kW | .3 | | Shaft power | | kW | | |
| 20 | Pump weight | kg | | | | Efficiency | | % | |
| 21 | Total weight | kg | 26.0 | | NPSH 3% | | m | | |

| Materials | | | |
|-----------|-----------------------------|-----------------------------|--|
| Pump | | Shaft Seal | |
| 22 | | | |
| 23 | Pump body | Stainless steel / AISI 316L | Single mechanical seal, without shaft sleeve |
| 24 | Impeller | Stainless steel / AISI 316L | Uniten 3K |
| 25 | SEAL HOUSING | Stainless steel / AISI 316L | Mechanical seal diameter |
| 26 | Wear ring | Stainless steel / AISI 316L | 1. Rotating ring |
| 27 | Counterwear ring | Stainless steel / AISI 316L | 2. Stationary ring |
| 28 | Shaft extension | Stainless steel / AISI 316L | 3. Secondary seal |
| 29 | Rigid shaft coupling | Stainless steel / AISI 316 | 4. Springs |
| 30 | Impeller locknut and washer | Stainless steel / AISI 316 | 5. Others |
| 31 | Tab | Stainless steel / AISI 316L | Gaskets of the pump |
| 32 | Fill/drain plugs | Stainless steel / AISI 316 | |
| 33 | | | |
| 34 | | | |
| 35 | | | |
| 36 | | | |
| 37 | | | |
| 38 | | | |
| 39 | | | |
| 40 | | | |
| 41 | | | |

| Motor data | | | |
|------------|-----------------|----------------------|----------------------|
| 42 | Manufacturer | Lowara LM | |
| 43 | Specific design | IE2 3ph Flange Motor | |
| 44 | Type | LLM471B14/304 | |
| 45 | Rated power | 0.37 kW | Rated current |
| 46 | Nominal speed | 1410 rpm | Rated voltage |
| 47 | Frame size | 71 | Service factor |
| 48 | Weight | kg 6.0 | Degree of protection |

| Remarks | |
|---------|--|
| 49 | |
| 50 | |
| 50 | |
| 52 | |

ESHE 25-200/03/X45RSSA

Performance curve

Company name
Contact
Phone number
e-mail address

| | Ø mm | Pump capacity | | | Pump head | | Shaft power P2 | | | Frequency | Hz | 50 |
|--------|---------|------------------------------|-----------|----------------|-------------|-------------|----------------|---------|----------------|-----------------|-----|------|
| | | Operating range Min. m³/h | Max. m³/h | η Max. m³/h | H(Q=0) m | η Max. m | P2(Q=0) kW | Max. kW | η Max. kW | Operating speed | rpm | 1410 |
| actual | 178 | 4.38 | 13.1 | 8.36 | 8.89 | 6.2 | 0.3 | 0.269 | Nominal flow | m³/h | 0 | |
| Min. | 0 | / | / | 8.36 | 8.89 | 6.2 | / | 0.269 | Nominal head | m | 0 | |
| Max. | 195 | / | / | 10.2 | 11.3 | 8.01 | / | 0.406 | Inlet pressure | kPa | 0 | |
| | | | | | | | | | Static head | m | 0 | |

Power datas referred to:

hydr. Performance acceptance acc. To EN ISO 9906 Class Grade 3B

Water, pure [100%] ; 4°C; 1000kg/m³; 1.57mm²/s

MEI: N.A - according to Ecodesign Directive 2009/125/EC and Regulation (EU) No.547/2012

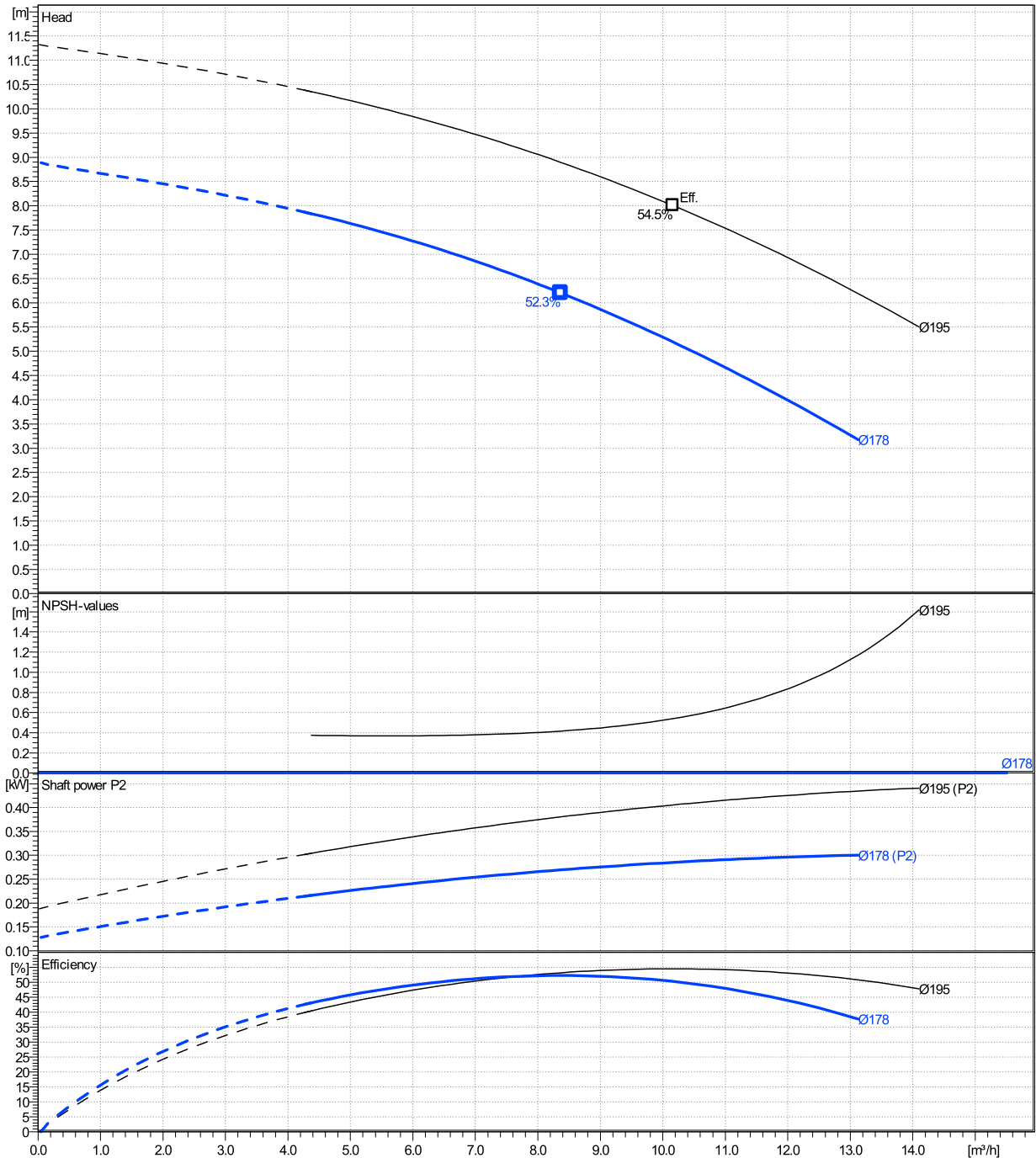

ESHE 25-200/03/X45RSSA

Dimensions

Company name
Contact
Phone number
e-mail address

Close coupled

LLM471B14/304

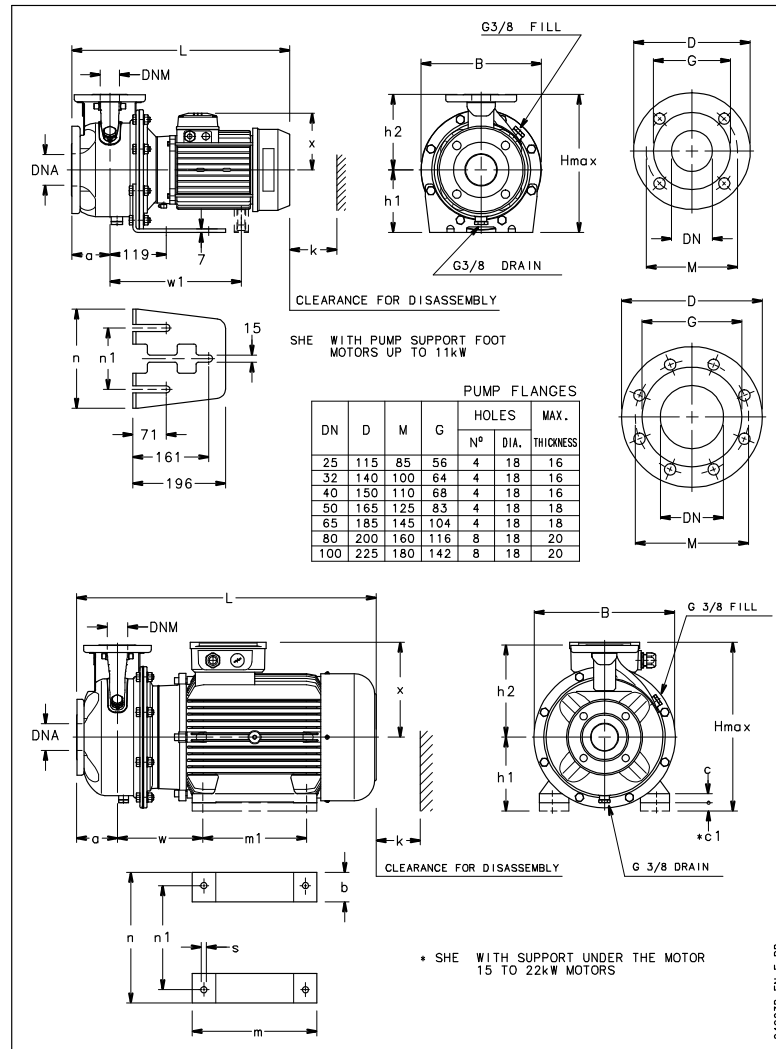

| Dimensions | | [mm] | |
|------------|-----|--------|--|
| a | 80 | | |
| B | 284 | | |
| DNA | 50 | | |
| DNM | 25 | | |
| h1 | 160 | | |
| h2 | 180 | | |
| Hmax | 340 | | |
| k | 98 | | |
| L | 411 | | |
| n | 230 | | |
| n1 | 130 | | |
| x | 121 | | |

| Weight | |
|--------------|-------|
| Total weight | 26 kg |

| Connections | | | |
|-----------------------|-----|-------------------------|-----|
| Suction nozzle | | Discharge nozzle | |
| DN 50 | | DN 25 | |
| PN 16 | | PN 16 | |
| EN1092-1 | | EN1092-1 | |
| D | 165 | D | 115 |
| Dia. Holes | 18 | Dia. Holes | 18 |
| DN | 50 | DN | 25 |
| G | 83 | G | 56 |
| M | 125 | M | 85 |
| Max thickness | 16 | Max thickness | 16 |

Dimensions and weight without obligation

| | | | | | |
|---------|------------------------|------------|------------|-------------|------------|
| Project | Xlect-20106422 | Created by | | Last update | 12/16/2024 |
| Block | ESHE 25-200/40/P25VSSA | Created on | 12/16/2024 | | |