

# ESHE 80-160/110/P25VSNA

## Technical data

Company name  
Contact  
Phone number  
e-mail address

Operating data						
1	Pumpe type	Single head pump		Fluid	Water, pure	
2	No. of pumps	1		Operating temperature t A	°C	4
3	Nominal flow	m <sup>3</sup> /h	0	Max / Min Operating Temperature mech. Seal	°C	120 / -10
4	Nominal head	m	0	pH-value at t A		7
5	Static head	m	0	Density at t A	kg/m <sup>3</sup>	1000
6	Inlet pressure	kPa	0	Kin. viscosity at t A	mm <sup>2</sup> /s	1.569
7	Environmental temperature	°C	20	Vapor pressure at t A	kPa	100
8	Available system NPSH	m	0	Altitude		0

Pump data						
9	Lubrication	Standard, Grease lubrication [Std]				
10	Execution					
11	Design	Horizontal				Impeller Ø
12	Operating speed	2910 rpm	Stages	1		
13	Suction nozzle	DN 100	/	PN 16	/	EN1092-1
14	Discharge nozzle	DN 80	/	PN 16	/	EN1092-1
15	Max. casing pressure	kPa	1200			Flow
16	Max. working pressure	kPa	335.8			
17	Impeller type	Radial impeller				Head
18	Head H(Q=0)	m	34			
19	Max. shaft power	kW	11.5			
20	Pump weight	kg				Shaft power
21	Total weight	kg	94.0			Efficiency
						NPSH 3%

Materials						
22		Pump			Shaft Seal	
23	Pump body	Stainless steel / AISI 316L			Single mechanical seal, without shaft sleeve	
24	Impeller	Stainless steel / ASTMCF8M			Uniten 3K	VBVGG
25	SEAL HOUSING	Stainless steel / AISI 316L			Mechanical seal diameter	
26	Wear ring	Stainless steel / AISI 316L			1. Rotating ring	Ceramic
27	Counterwear ring	Stainless steel / AISI 316L			2. Stationary ring	Carbon graphite resin impregnated
28	Shaft extension	Stainless steel / AISI 316L			3. Secondary seal	Fluorine rubber (FKM)
29	Rigid shaft coupling	Stainless steel / AISI 316			4. Springs	CrNiMo - Steel
30	Impeller locknut and washer	Stainless steel / AISI 316			5. Others	CrNiMo - Steel
31	Tab	Stainless steel / AISI 316L			Gaskets of the pump	
32	Fill/drain plugs	Stainless steel / AISI 316			Fluorine rubber (FKM)	
33						
34						
35						
36						
37						
38						
39						
40						
41						

Motor data					
Electrical and dimensional data refer to IE3 motor					
42	Manufacturer	Lowara PLM			
43	Specific design	IE3 3ph Flange Motor			
44	Type	PLM 132 B14 11 kW			
45	Rated power	11 kW	Rated current	20.2 A	
46	Nominal speed	2910 rpm	Rated voltage	400 V	
47	Frame size	132	Service factor	1	
48	Weight	kg 63.0	Degree of protection	IP55	

Remarks					
49					
50					
50					
52					

# ESHE 80-160/110/P25VSNA

## Performance curve

Company name  
Contact  
Phone number  
e-mail address

	Ø mm	Pump capacity			Pump head		Shaft power P2			Frequency	Hz
		Operating range Min. m³/h	Max. m³/h	η Max. m³/h	H(Q=0) m	η Max. m	P2(Q=0) kW	Max. kW	η Max. kW	Operating speed	rpm
actual	169	72.2	199	126	34.2	25	11.5	11.4	Nominal flow	m³/h	0
Min.	0	/	/	126	34.2	25	/	11.4	Nominal head	m	0
Max.	186	/	/	146	48.1	36.2	/	18.4	Inlet pressure	kPa	0
									Static head	m	0

**Power datas referred to:**

hydr. Performance acceptance acc. To EN ISO 9906 Class Grade 3B

Water, pure [100%] ; 4°C; 1000kg/m³; 1.57mm²/s

MEI: N.A - according to Ecodesign Directive 2009/125/EC and Regulation (EU) No.547/2012

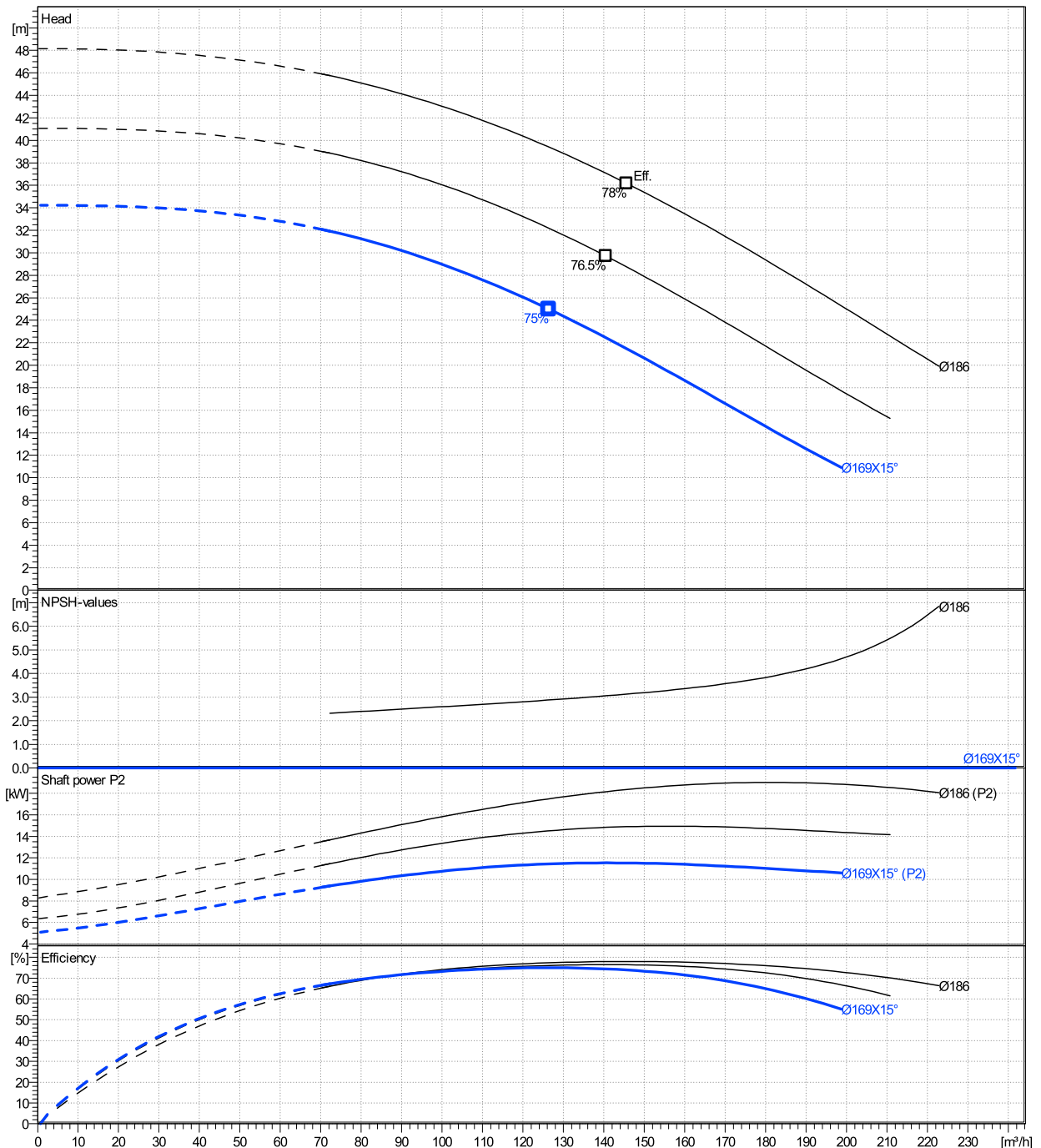

**ESHE 80-160/110/P25VSNA**

**Dimensions**

Company name  
Contact  
Phone number  
e-mail address

Close coupled

PLM 132 B14 11 kW

Electrical and dimensional data refer to IE3 motor

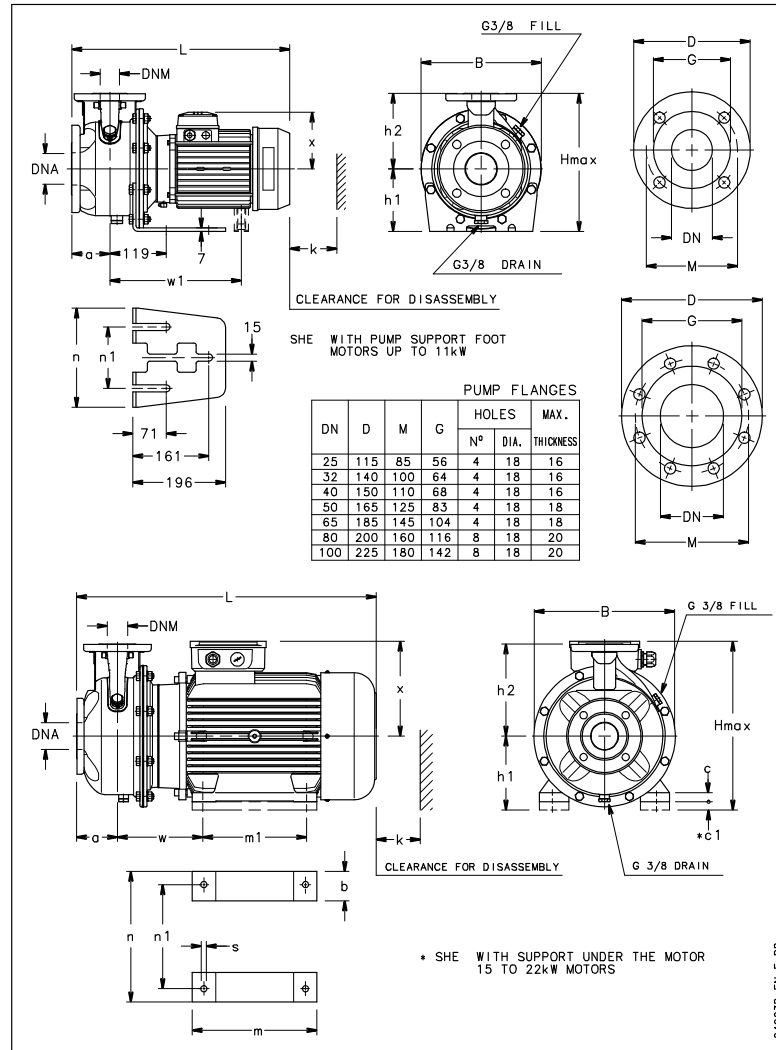

**Dimensions [ mm ]**

a	125
B	345
DNA	100
DNM	80
h1	180
h2	225
Hmax	405
k	160
L	630
n	265
n1	130
w1	343
x	191

**Weight**

<b>Total weight</b>	<b>94 kg</b>
---------------------	--------------

**Connections**

Suction nozzle		Discharge nozzle	
DN 100	PN 16	DN 80	PN 16
EN1092-1		EN1092-1	
D	225	D	200
Dia. Holes	18	Dia. Holes	18
DN	100	DN	80
G	142	G	114
M	180	M	160
Max thickness	20	Max thickness	20

**Dimensions and weight without obligation**

Project	Xylect-20106709	Created by		Last update	12/16/2024
Block	ESHE 80-160/185/P25VSNA	Created on	12/16/2024		