

ESHS 25-250/15/P46PSSA

Technical data

Company name
Contact
Phone number
e-mail address

Operating data						
1	Pumpe type	Single head pump		Fluid	Water, pure	
2	No. of pumps	1		Operating temperature t A	°F	39.2
3	Nominal flow	US g.p.m.	0	Max / Min Operating Temperature mech. Seal	°F	120 / -10
4	Nominal head	ft	0	pH-value at t A		7
5	Static head	ft	0	Density at t A	lb/ft ³	62.4
6	Inlet pressure	psi	0	Kin. viscosity at t A	ft ² /s	1.689E-5
7	Environmental temperature	°F	68	Vapor pressure at t A	psi	14.5
8	Available system NPSH	ft	0	Altitude		0

Pump data									
9	Lubrication	Standard, Grease lubrication [Std]							
10	Execution								
11	Design	Horizontal		Impeller Ø	Max.	inch	8 11/16		
12	Operating speed	1750 rpm	Stages		1	designed	inch	8 11/16	
13	Suction nozzle	DN 50	/	PN 16	/	EN1092-1	Min.	inch	7 3/16
14	Discharge nozzle	DN 25	/	PN 16	/	EN1092-1	Nominal US g.p.m.		
15	Max. casing pressure	psi	174		Flow	Max-	US g.p.m.	72.6	
16	Max. working pressure	psi	32			Min-	US g.p.m.	19.8	
17	Impeller type	Radial impeller		Head	Nominal	ft			
18	Head H(Q=0)	ft	74		at Qmax	ft	40.5		
19	Max. shaft power	hp	1.9		at Qmin	ft	70.7		
20	Pump weight	kg			Shaft power	hp			
21	Total weight	lb	110.2		Efficiency	%			
					NPSH 3%	ft			

Materials			
Pump		Shaft Seal	
22			
23	Pump body	Stainless steel / AISI 316L	Single mechanical seal, without shaft sleeve
24	Impeller	Stainless steel / AISI 316L	Uniten 3K
25	SEAL HOUSING	Stainless steel / AISI 316L	Mechanical seal diameter
26	Wear ring	Stainless steel / AISI 316L	7/8 inch
27	Counterwear ring	Stainless steel / AISI 316L	1. Rotating ring
28	Rigid shaft coupling	Stainless steel / AISI 316L	Ceramic
29	Impeller locknut and washer	Stainless steel / AISI 316	2. Stationary ring
30	Tab	Stainless steel / AISI 316L	Carbon graphite resin impregnated
31	Fill/drain plugs	Stainless steel / AISI 316	3. Secondary seal
32			Fluorine rubber (FKM)
33			4. Springs
34			CrNiMo - Steel
35			5. Others
36			CrNiMo - Steel
37			Gaskets of the pump
38			Fluorine rubber (FKM)
39			
40			
41			

Motor data			
Electrical and dimensional data refer to IE3 motor			
42	Manufacturer	Lowara PLM	
43	Specific design	IE3 3ph Flange Motor - Premium Efficiency	
44	Type	PLM 90 B5 1,5 kW	
45	Rated power	2.0115 hp	Rated current
46	Nominal speed	1734 rpm	6.34 A
47	Frame size	90	Rated voltage
48	Weight	lb 49.8	220 V
			Service factor
			1
			Degree of protection
			IP55

Remarks	
49	
50	
50	
52	

ESHS 25-250/15/P46PSSA

Performance curve

Company name
Contact
Phone number
e-mail address

	Ø mm	Pump capacity Operating range η			Pump head η		Shaft power P2 η			Frequency	Hz	
		Min. US g.p.m.	Max. US g.p.m.	Max. US g.p.m.	H(Q=0) ft	Max. ft	P2(Q=0) hp	Max. hp	Max. hp	Operating speed	rpm	
actual	8 11/16	19.8	72.6	54.3	73.7	54.9	1.94	1.77	Nominal flow	US g.p.m.	0	
Min.	0	/	/	43.4	46.1	32.7	/	0.881	Nominal head	ft	0	
Max.	8 11/16	/	/	54.3	73.7	54.9	/	1.77	Inlet pressure	psi	0	
									Static head	ft	0	

Power datas referred to:

hydr. Performance acceptance acc. To EN ISO 9906 Class Grade 3B

Water, pure [100%] ; 39.2°F; 62.4lb/ft³; 1.69E-5ft²/s

MEI: N.A - according to Ecodesign Directive 2009/125/EC and Regulation (EU) No.547/2012

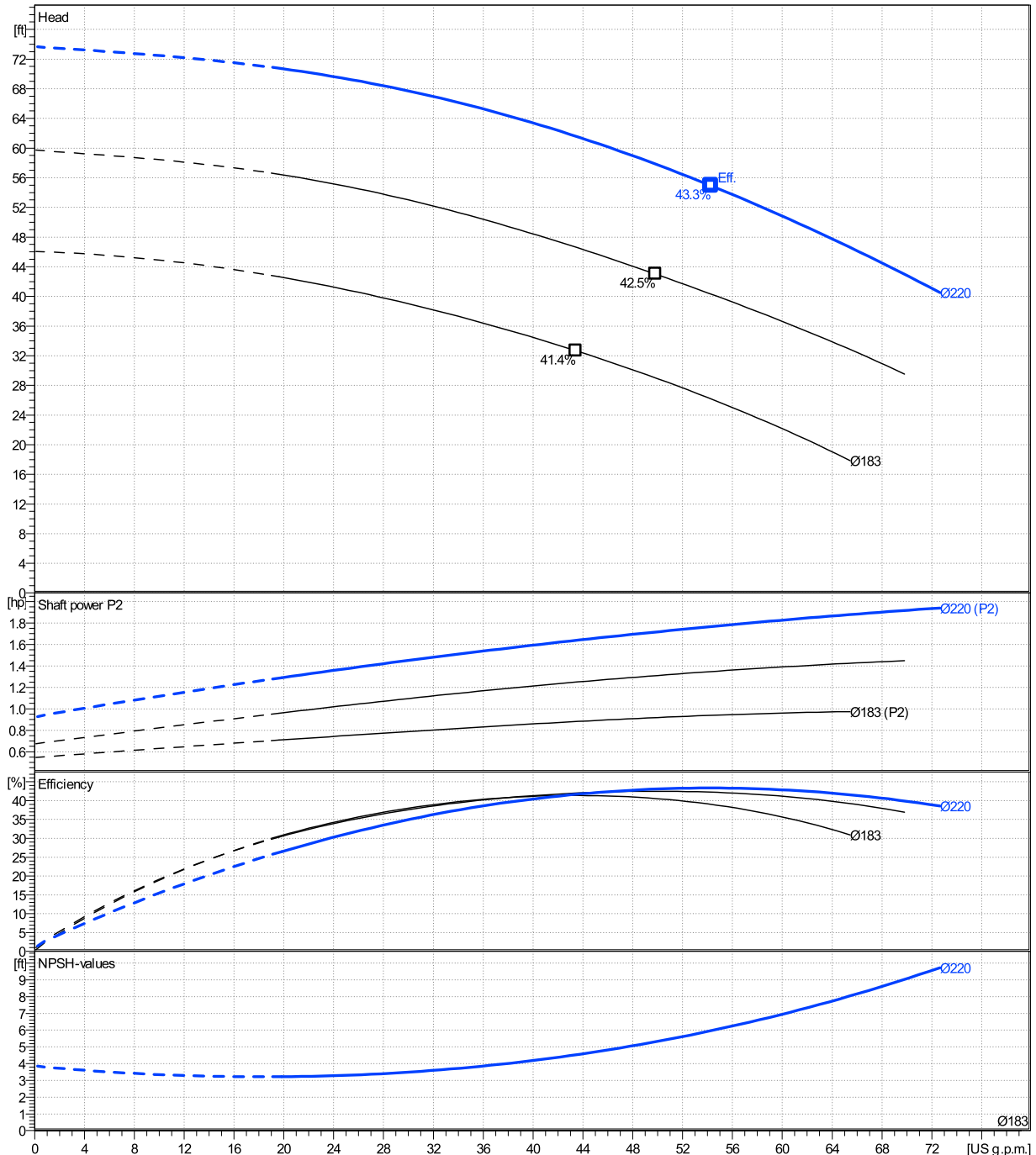

ESHS 25-250/15/P46PSSA

Dimensions

Company name
Contact
Phone number
e-mail address

Rigid coupling

PLM 90 B5 1,5 kW

Electrical and dimensional data refer to IE3 motor

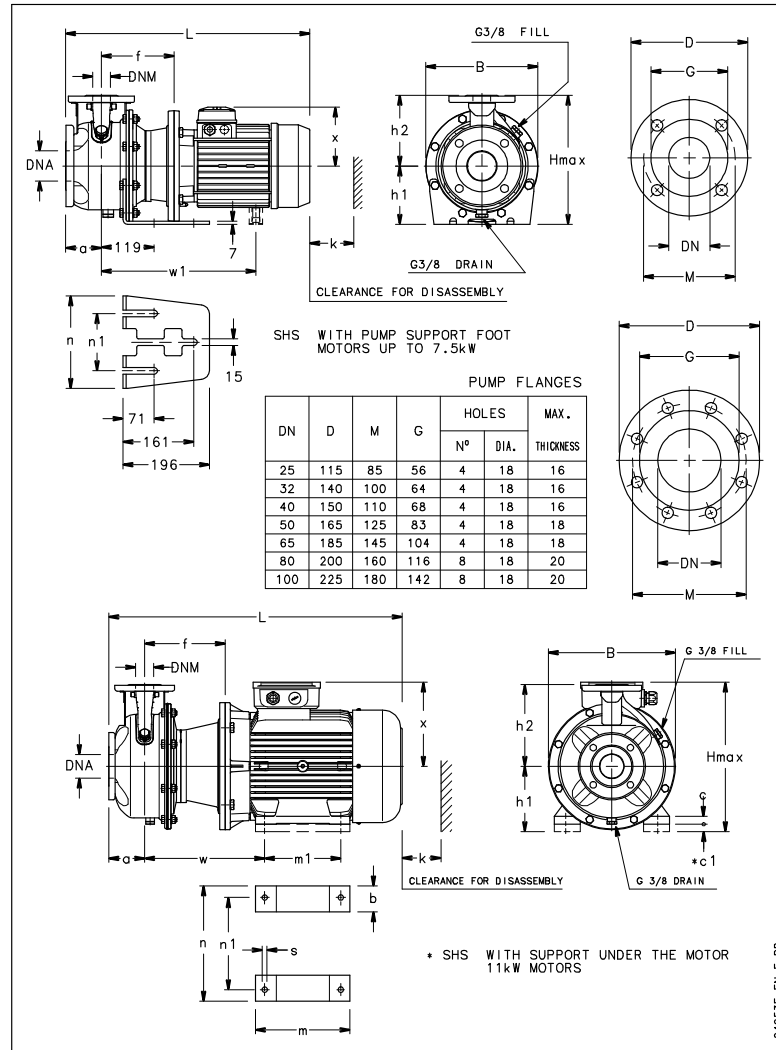

Dimensions [inch]

a	3 ¹⁵ / ₁₆		
B	13 ⁹ / ₁₆		
DNA	1 ¹⁵ / ₁₆		
DNM	1		
f	6 ¹ / ₈		
h1	7 ¹ / ₁₆		
h2	8 ⁷ / ₈		
Hmax	15 ¹⁵ / ₁₆		
k	3 ⁷ / ₈		
L	21 ³ / ₄		
n	10 ⁷ / ₁₆		
n1	5 ¹ / ₈		
x	5 ¹ / ₄		

Weight

Total weight 50 kg

Connections

Suction nozzle		Discharge nozzle	
DN 50		DN 25	
PN 16		PN 16	
EN1092-1		EN1092-1	
D	6 ¹ / ₂	D	4 ¹ / ₂
Dia. Holes	1 ¹⁵ / ₁₆	Dia. Holes	1 ¹⁵ / ₁₆
DN	1 ¹⁵ / ₁₆	DN	1
G	3 ¹ / ₄	G	2 ³ / ₁₆
M	4 ¹⁵ / ₁₆	M	3 ³ / ₈
Max thickness	1 ¹⁵ / ₁₆	Max thickness	1 ¹⁵ / ₁₆

Dimensions and weight without obligation

Project Xlect-20183008
Block ESHS 25-250/110/P26PSSA

Created by
Created on 1/12/2025

Last update 1/12/2025