

LNEE 40-200/55/P25VCS4

Technical data

Company name
Contact
Phone number
e-mail address

Operating data					
1	Pumpe type	Single head pump		Fluid	Water
2	No. of pumps	1		Operating temperature t A	°C 4
3	Nominal flow	m³/h	0	Max / Min Operating Temperature mech. Seal	°C 120 / -25
4	Nominal head	m	0	pH-value at t A	7
5	Static head	m	0	Density at t A	kg/m³ 1000
6	Inlet pressure	kPa	0	Kin. viscosity at t A	mm²/s 1.569
7	Environmental temperature	°C	20	Vapor pressure at t A	kPa 100
8	Available system NPSH	m	0	Altitude	0

Pump data					
9	Lubrication	Standard, Grease lubrication [Std]			
10	Execution				
11	Design	In-Line single head		Impeller Ø	Max. mm 205
12	Operating speed	2900 rpm	Stages 1		designed mm 186
13	Suction nozzle	DN 40 /	PN 16 / EN1092-2		Min. mm 158
14	Discharge nozzle	DN 40 /	PN 16 / EN1092-2	Flow	Nominal m³/h
15	Max. casing pressure	kPa			Max- m³/h 30
16	Max. working pressure	kPa	446.8	Min- m³/h 8.6	
17	Impeller type	Radial impeller		Head	Nominal m
18	Head H(Q=0)	m	46		at Qmax m 33.8
19	Max. shaft power	kW	5.2	Shaft power kW	at Qmin m 44.2
20	Pump weight	kg		Efficiency %	
21	Total weight	kg	73.0	NPSH 3%	m

Materials					
22		Pump		Shaft Seal	
23	Volute Casing	Cast iron		Single mechanical seal, without shaft sleeve	
24	Casing Cover	Cast iron		eMG12 - Ø22mm	BQ7EGG-WA
25	Impeller	Stainless steel / AISI 304		Mechanical seal diameter	22 mm
26	Stub shaft	Stainless steel / AISI 316L		1. Rotating ring	Carbon graphite resin impregnated
27	Wear ring	Stainless steel / AISI 304		2. Stationary ring	SiC, silicon carbide, sintered press.less
28	Impeller lock nut and washer	Stainless steel / AISI 304		3. Secondary seal	Ethylene propylene rubber (EPDM)
29	Impeller key	Stainless steel / AISI 316L		4. Springs	CrNiMo - Steel
30	Fill and drain plugs	Nickel-plated brass		5. Others	EPDM - WRAS
31				Gaskets of the pump	Ethylene propylene rubber (EPDM)
32					
33					
34					
35					
36					
37					
38					
39					
40					
41					

Motor data					
Electrical and dimensional data refer to IE3 motor					
42	Manufacturer	Lowara			
43	Specific design	IE3 3ph Flange Motor			
44	Type	PLM 112 B14 5,5 kW			
45	Rated power	5.5 kW	Rated current	10.4 A	
46	Nominal speed	2880 rpm	Rated voltage	400 V	
47	Frame size	112	Service factor	1	
48	Weight	kg 35.5	Degree of protection	IP55	

Remarks					
49					
50					
50					
52					

LNEE 40-200/55/P25VCS4

Performance curve

Company name
Contact
Phone number
e-mail address

	Ø mm	Pump capacity			Pump head		Shaft power P2			Frequency	Hz	
		Operating range Min. m³/h	Max. m³/h	η Max. m³/h	H(Q=0) m	η Max. m	P2(Q=0) kW	Max. kW	η Max. kW	Operating speed	rpm	
actual	186	8.64	30	25.9	45.5	37.6		5.17	4.83	Nominal flow	m³/h	0
Min.	0	/	/	20.3	31.6	26.8		/	2.79	Nominal head	m	0
Max.	205	/	/	29.6	56.6	47.3		/	6.93	Inlet pressure	kPa	0
										Static head	m	0

Power datas referred to:

hydr. Performance acceptance acc. To EN ISO 9906 Class Grade 3B

Water [100%] ; 4°C; 1000kg/m³; 1.57mm²/s

MEI: N.A - according to Ecodesign Directive 2009/125/EC and Regulation (EU) No.547/2012

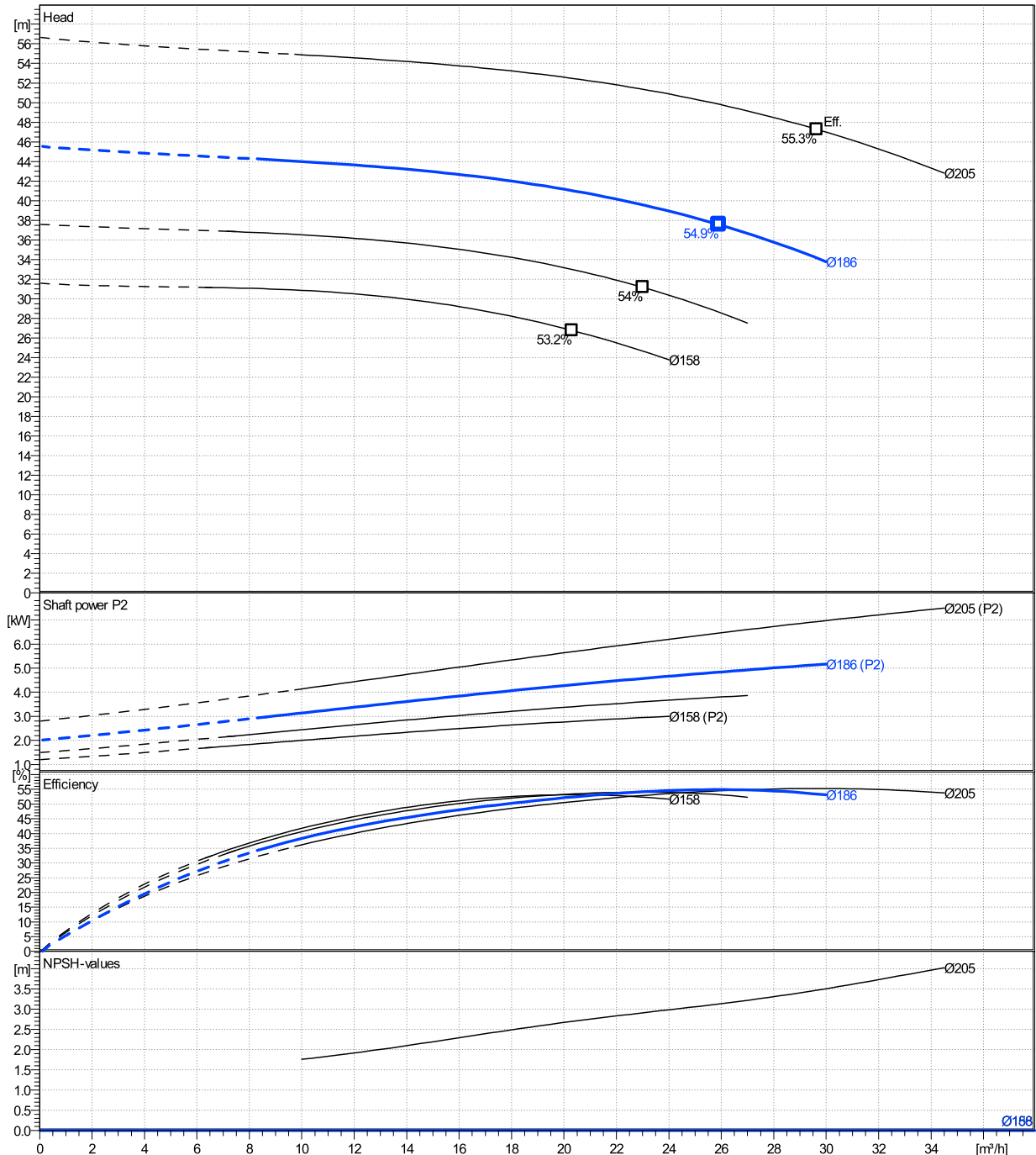

LNEE 40-200/55/P25VCS4

Dimensions

Company name
Contact
Phone number
e-mail address

Close coupled

PLM 112 B14 5,5 kW

Electrical and dimensional data refer to IE3 motor

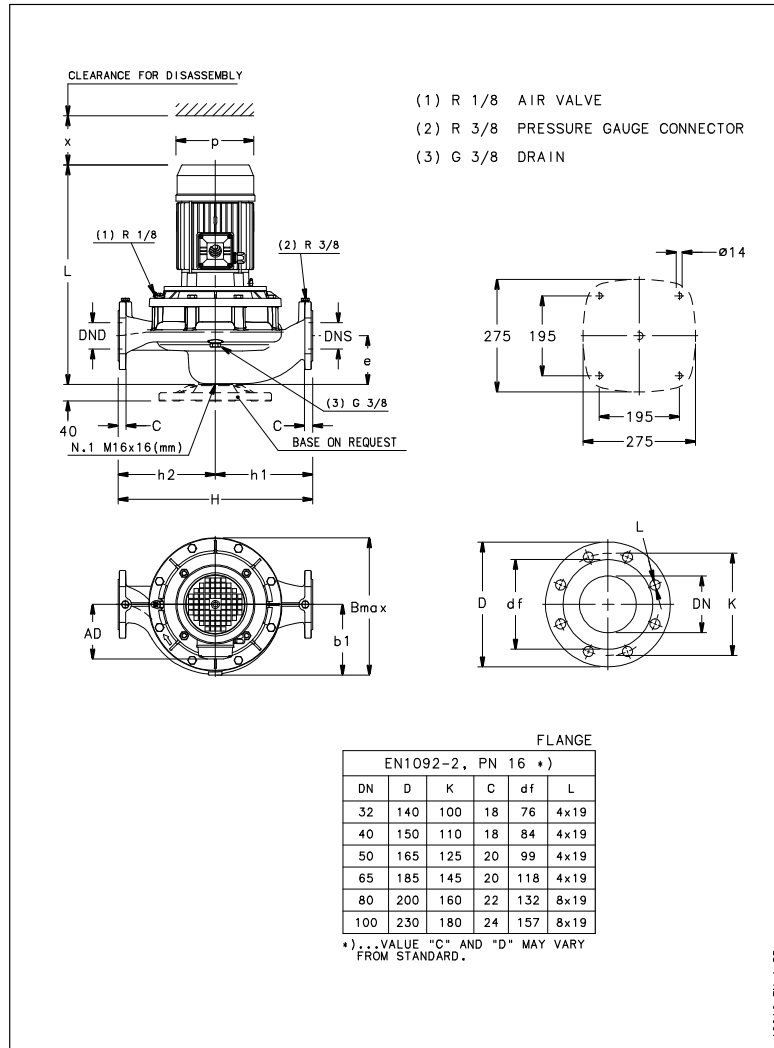

Dimensions [mm]

AD	168
b1	168
Bmax	336
DND	40
DNS	40
e	110
H	440
h1	220
h2	220
L	563
p	214
x	104

Weight

Total weight	73 kg
--------------	-------

Connections

Suction nozzle		Discharge nozzle	
DN 40		DN 40	
PN 16		PN 16	
EN1092-2		EN1092-2	
C	18	C	18
D	150	D	150
df	84	df	84
DN	40	DN	40
K	110	K	110
L	4 x 19	L	4 x 19

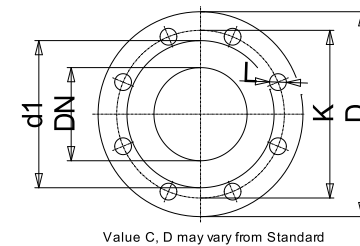

Dimensions and weight without obligation

Project	Xylect-20127611
Block	LNEE 40-200/11/P45RCS4

Created by
Created on 12/20/2024

Last update 12/20/2024