

LNEE 50-200/15/P46PCS4

Technical data

Company name
Contact
Phone number
e-mail address

Operating data					
1	Pumpe type	Single head pump		Fluid	Water
2	No. of pumps	1		Operating temperature t A	°F 39.2
3	Nominal flow	US g.p.m.	0	Max / Min Operating Temperature mech. Seal	°F 120 / -25
4	Nominal head	ft	0	pH-value at t A	7
5	Static head	ft	0	Density at t A	lb/ft³ 62.4
6	Inlet pressure	psi	0	Kin. viscosity at t A	ft²/s 1.689E-5
7	Environmental temperature	°F	68	Vapor pressure at t A	psi 14.5
8	Available system NPSH	ft	0	Altitude	0

Pump data					
9	Lubrication	Standard, Grease lubrication [Std]			
10	Execution				
11	Design	In-Line single head		Impeller Ø	Max. inch 6 15/16
12	Operating speed	1750 rpm	Stages 1		designed inch 6 15/16
13	Suction nozzle	DN 50 /	PN 16 /	EN1092-2	Min. inch 6 15/16
14	Discharge nozzle	DN 50 /	PN 16 /	EN1092-2	Flow
15	Max. casing pressure	psi			Nominal US g.p.m.
16	Max. working pressure	psi	20.1		Max- US g.p.m. 145.3
17	Impeller type	Radial impeller		Head	Min- US g.p.m. 35.2
18	Head H(Q=0)	ft	46		Nominal ft
19	Max. shaft power	hp	2		at Qmax ft 24.8
20	Pump weight	kg			at Qmin ft 46.9
21	Total weight	lb	138.9	Shaft power	hp
				Efficiency	%
				NPSH 3%	ft

Materials					
22		Pump		Shaft Seal	
23	Volute Casing	Cast iron		Single mechanical seal, without shaft sleeve	
24	Casing Cover	Cast iron		eMG12 - Ø22mm	BQ7EGG-WA
25	Impeller	Stainless steel / AISI 304		Mechanical seal diameter	7/8 inch
26	Stub shaft	Stainless steel / AISI 316L		1. Rotating ring	Carbon graphite resin impregnated
27	Wear ring	Stainless steel / AISI 304		2. Stationary ring	SiC, silicon carbide, sintered press.less
28	Impeller lock nut and washer	Stainless steel / AISI 304		3. Secondary seal	Ethylene propylene rubber (EPDM)
29	Impeller key	Stainless steel / AISI 316L		4. Springs	CrNiMo - Steel
30	Fill and drain plugs	Nickel-plated brass		5. Others	EPDM - WRAS
31				Gaskets of the pump	Ethylene propylene rubber (EPDM)
32					
33					
34					
35					
36					
37					
38					
39					
40					
41					

Motor data					
Electrical and dimensional data refer to IE3 motor					
42	Manufacturer	Lowara			
43	Specific design	IE3 3ph Flange Motor			
44	Type	PLM 90 B14 1,5 kW			
45	Rated power	2.0115 hp	Rated current	6.34 A	
46	Nominal speed	1734 rpm	Rated voltage	220 V	
47	Frame size	90	Service factor	1	
48	Weight	lb 44.1	Degree of protection	IP55	

Remarks					
49					
50					
50					
52					

LNEE 50-200/15/P46PCS4

Performance curve

Company name
Contact
Phone number
e-mail address

	Ø mm	Pump capacity			Pump head		Shaft power P2			Frequency		Hz	60
		Operating range Min. US g.p.m.	Max. US g.p.m.	η Max. US g.p.m.	H(Q=0) ft	η Max. ft	P2(Q=0) hp	Max. hp	η Max. hp	Operating speed rpm	1750		
actual	6 15/16	35.2	145	96.9	46.4	40.2		2.05	1.73	Nominal flow	US g.p.m.	0	
Min.	0	/	/	96.9	46.4	40.2		/	1.73	Nominal head	ft	0	
Max.	6 15/16	/	/	96.9	46.4	40.2		/	1.73	Inlet pressure	psi	0	
										Static head	ft	0	

Power datas referred to:

hydr. Performance acceptance acc. To EN ISO 9906 Class Grade 3B

Water [100%] ; 39.2°F; 62.4lb/ft³; 1.69E-5ft²/s

MEI: N.A - according to Ecodesign Directive 2009/125/EC and Regulation (EU) No.547/2012

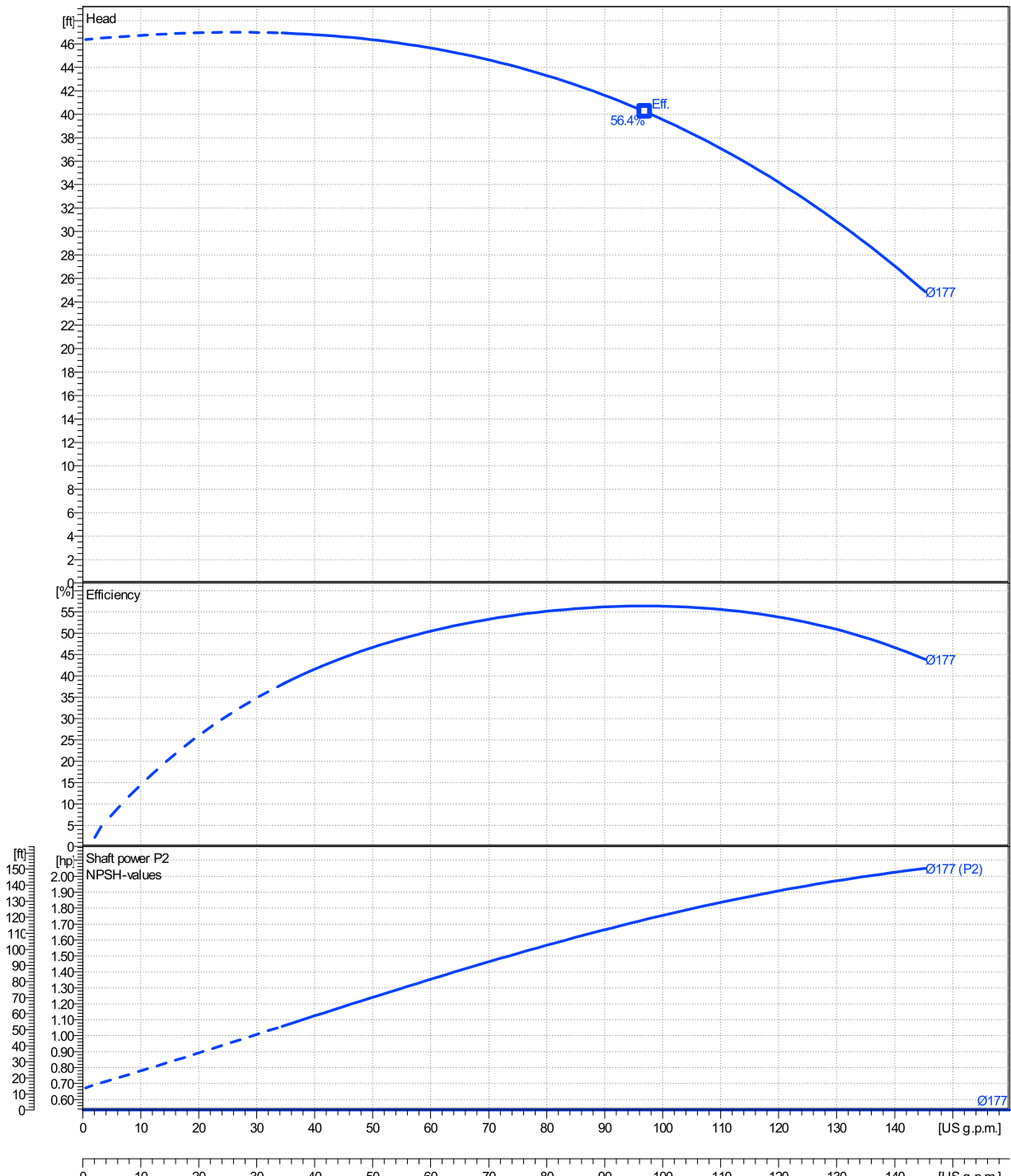

LNEE 50-200/15/P46PCS4

Dimensions

Company name
Contact
Phone number
e-mail address

Close coupled

PLM 90 B14 1,5 kW

Electrical and dimensional data refer to IE3 motor

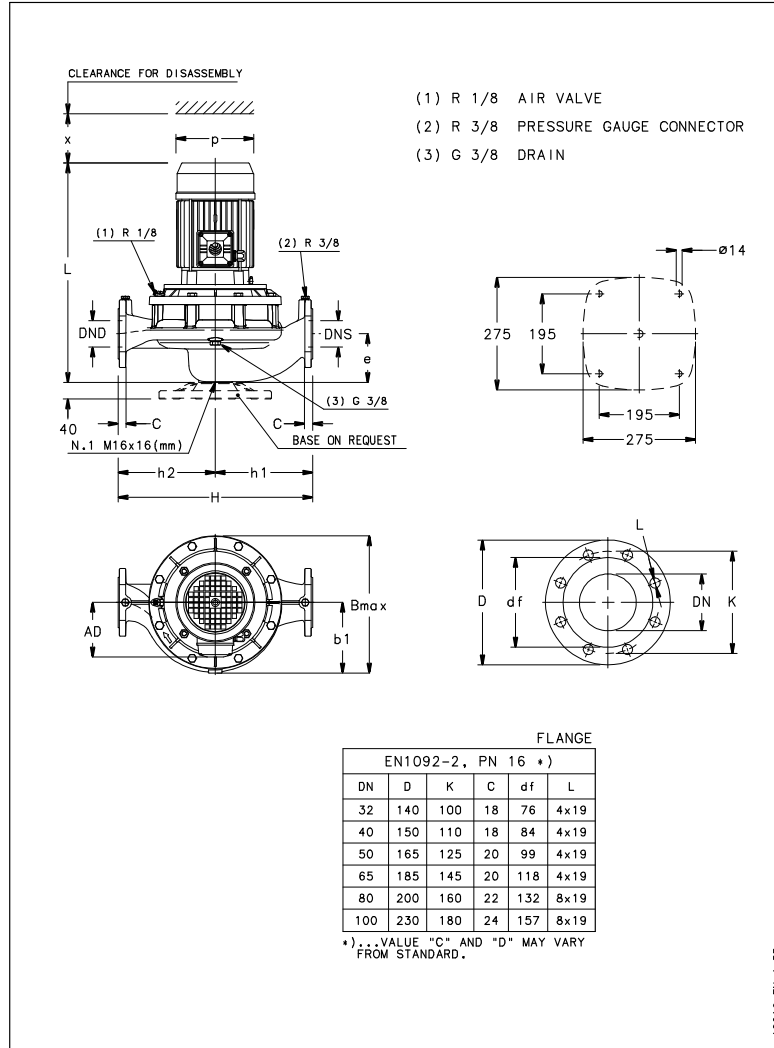

Dimensions [inch]

AD	5 1/4		
b1	6 5/8		
Bmax	13 1/4		
DND	1 15/16		
DNS	1 15/16		
e	4 3/8		
H	17 9/16		
h1	8 11/16		
h2	8 11/16		
L	20 1/16		
p	6 7/8		
x	4 1/4		

Weight

Total weight	63 kg
---------------------	--------------

Connections

Suction nozzle		Discharge nozzle	
DN 50		DN 50	
PN 16		PN 16	
EN1092-2		EN1092-2	
C	13/16	C	13/16
D	6 1/2	D	6 1/2
df	3 7/8	df	3 7/8
DN	1 15/16	DN	1 15/16
K	4 15/16	K	4 15/16
L	4 x 19	L	4 x 19

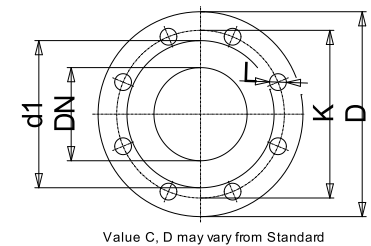

Dimensions and weight without obligation

Project	Xylect-20185360	Created by		Last update	1/13/2025
Block	LNEE 50-200/15/P46PCS4	Created on	1/13/2025		