

# LNES 50-200/75/P25VCS4

## Technical data

Company name  
Contact  
Phone number  
e-mail address

Operating data					
1	Pumpe type	Single head pump		Fluid	Water
2	No. of pumps	1		Operating temperature t A	°C 4
3	Nominal flow	m <sup>3</sup> /h	0	Max / Min Operating Temperature mech. Seal	°C 120 / -25
4	Nominal head	m	0	pH-value at t A	7
5	Static head	m	0	Density at t A	kg/m <sup>3</sup> 1000
6	Inlet pressure	kPa	0	Kin. viscosity at t A	mm <sup>2</sup> /s 1.569
7	Environmental temperature	°C	20	Vapor pressure at t A	kPa 100
8	Available system NPSH	m	0	Altitude	0

Pump data					
9	Lubrication	Standard, Grease lubrication [Std]			
10	Execution				
11	Design	In-line		Impeller Ø	Max. mm 199
12	Operating speed	2900 rpm	Stages 1		designed mm 179
13	Suction nozzle	DN 50 /	PN 16 / EN1092-2		Min. mm 165
14	Discharge nozzle	DN 50 /	PN 16 / EN1092-2	Flow	Nominal m <sup>3</sup> /h
15	Max. casing pressure	kPa			Max- m <sup>3</sup> /h 52
16	Max. working pressure	kPa	417.7	Min- m <sup>3</sup> /h 13.8	
17	Impeller type	Radial impeller		Head	Nominal m
18	Head H(Q=0)	m	43		at Qmax m 27.9
19	Max. shaft power	kW	7.6	Shaft power kW	at Qmin m 42.9
20	Pump weight	kg		Efficiency %	
21	Total weight	kg	104.2	NPSH 3% m	

Materials					
22		Pump		Shaft Seal	
23	Volute Casing	Cast iron		Single mechanical seal, without shaft sleeve	
24	Casing Cover	Cast iron		eMG12 - Ø22mm	BQ7EGG-WA
25	Impeller	Stainless steel / AISI 304		Mechanical seal diameter	22 mm
26	Stub shaft	Stainless steel / AISI 316L		1. Rotating ring	Carbon graphite resin impregnated
27	Wear ring	Stainless steel / AISI 304		2. Stationary ring	SiC, silicon carbide, sintered press.less
28	Impeller lock nut and washer	Stainless steel / AISI 304		3. Secondary seal	Ethylene propylene rubber (EPDM)
29	Impeller key	Stainless steel / AISI 316L		4. Springs	CrNiMo - Steel
30	Fill and drain plugs	Nickel-plated brass		5. Others	EPDM - WRAS
31				Gaskets of the pump	Ethylene propylene rubber (EPDM)
32					
33					
34					
35					
36					
37					
38					
39					
40					
41					

Motor data					
Electrical and dimensional data refer to IE3 motor					
42	Manufacturer	Lowara			
43	Specific design	IE3 3ph Flange Motor - Premium Efficiency			
44	Type	PLM 132 B5 7,5 kW			
45	Rated power	7.5 kW	Rated current	14.1 A	
46	Nominal speed	2920 rpm	Rated voltage	400 V	
47	Frame size	132	Service factor	1	
48	Weight	kg 56.0	Degree of protection	IP55	

Remarks					
49					
50					
50					
52					

# LNES 50-200/75/P25VCS4

## Performance curve

Company name  
Contact  
Phone number  
e-mail address

	Ø mm	Pump capacity			Pump head		Shaft power P2			Frequency	Hz	50
		Operating range Min. m³/h	Max. m³/h	η Max. m³/h	H(Q=0) m	η Max. m	P2(Q=0) kW	Max. kW	η Max. kW	Operating speed	rpm	2900
actual	179	13.8	52	39.3	42.6	36.7	7.56	6.64	Nominal flow	m³/h	0	
Min.	0	/	/	34.7	34.9	30.5	/	4.87	Nominal head	m	0	
Max.	199	/	/	46.4	55	46.6	/	9.38	Inlet pressure	kPa	0	
									Static head	m	0	

Power datas referred to:

hydr. Performance acceptance acc. To EN ISO 9906 Class Grade 3B

Water [100%] ; 4°C; 1000kg/m³; 1.57mm²/s

MEI: N.A - according to Ecodesign Directive 2009/125/EC and Regulation (EU) No.547/2012

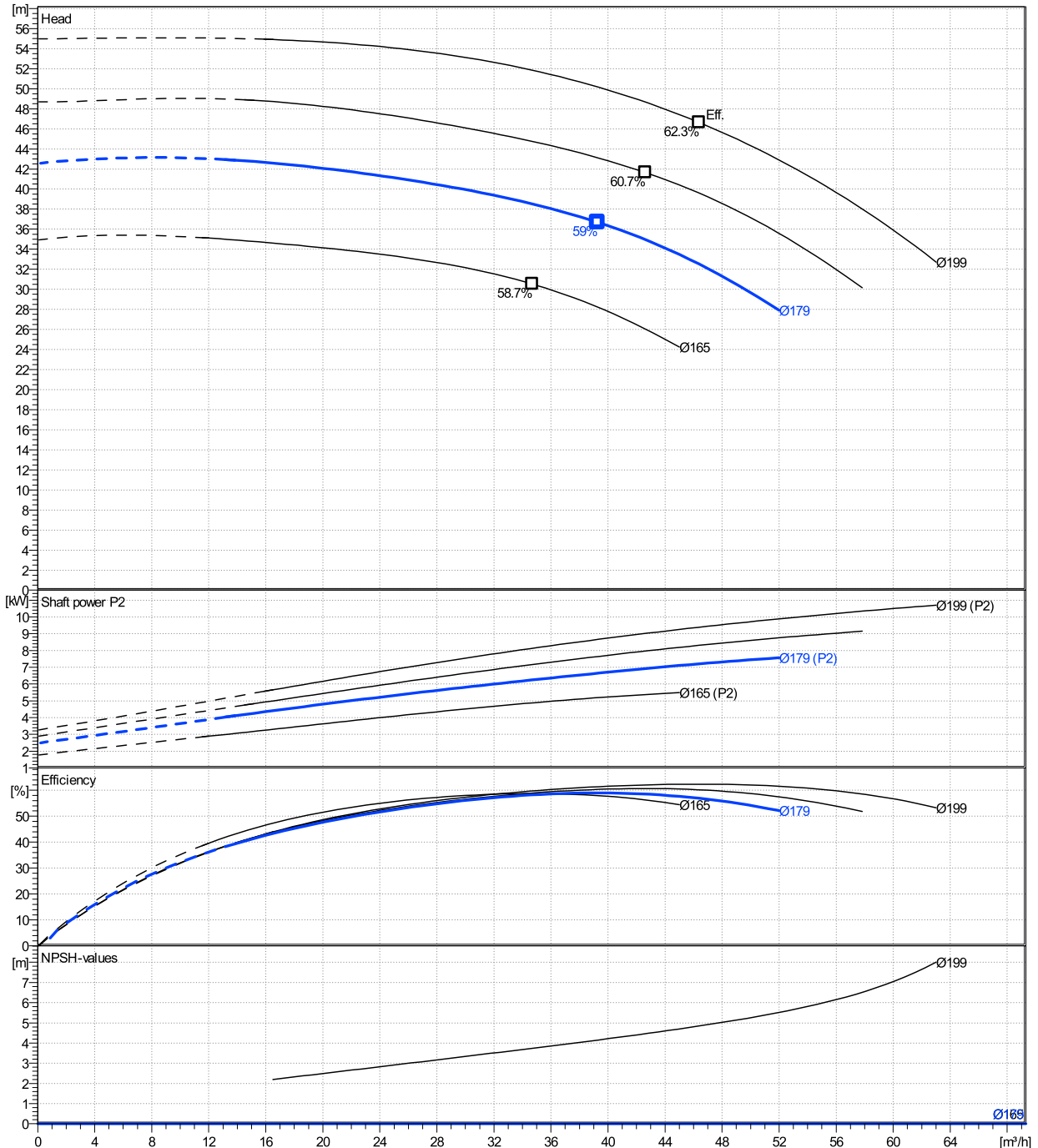

# LNES 50-200/75/P25VCS4

## Dimensions

Company name  
Contact  
Phone number  
e-mail address

Rigid coupling

PLM 132 B5 7,5 kW

Electrical and dimensional data refer to IE3 motor

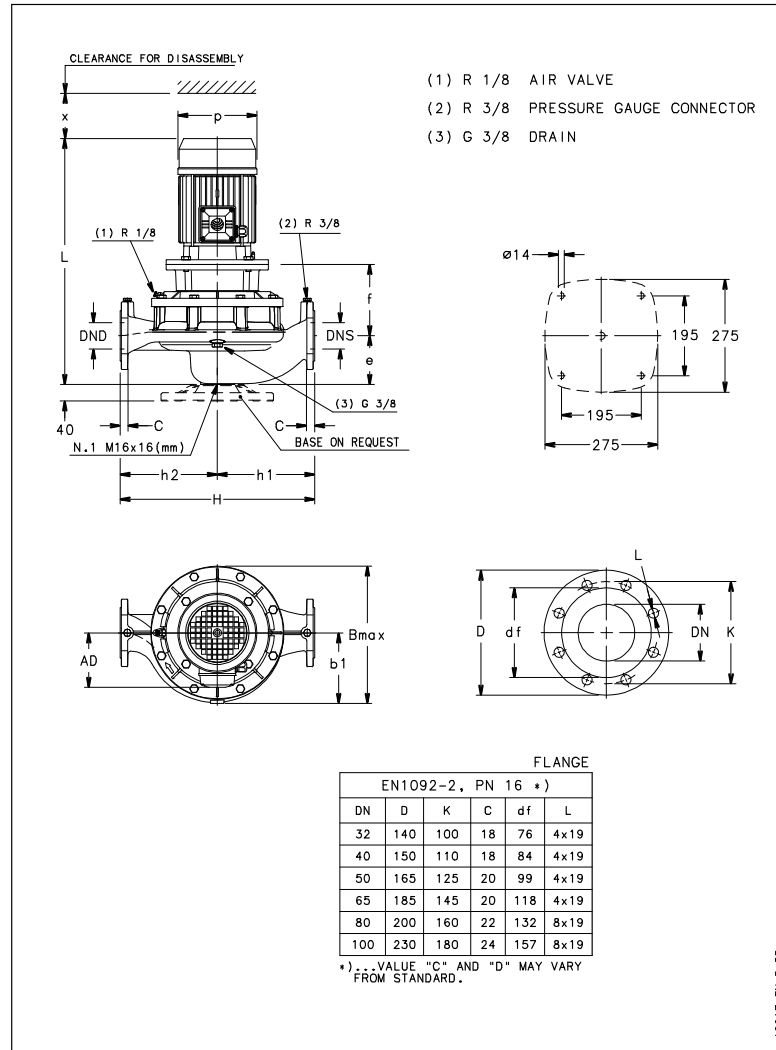

### Dimensions [ mm ]

AD	191
b1	168
Bmax	336
DNd	50
DNs	50
e	111
f	192
H	440
h1	220
h2	220
L	670
p	256
x	108

### Weight

Total weight	104.2 kg
--------------	----------

### Connections

Suction nozzle		Discharge nozzle	
DN 50		DN 50	
PN 16		PN 16	
EN1092-2		EN1092-2	
C	20	C	20
D	165	D	165
df	99	df	99
DN	50	DN	50
K	125	K	125
L	4 x 19	L	4 x 19

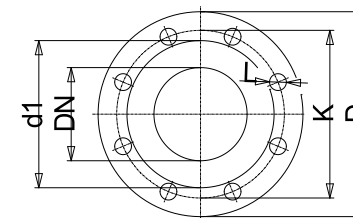

Value C, D may vary from Standard

### Dimensions and weight without obligation

Project Xlect-20128214  
Block LNES 50-200/15/P45RCS4

Created by  
Created on 12/21/2024

Last update 12/21/2024