

NSCE50-125/15/P46PCS4

Technical data

Company name
Contact
Phone number
e-mail address

Operating data					
1	Pumpe type	Single head pump	Fluid	Water, pure	
2	No. of pumps	1	Operating temperature t A	°F	39.2
3	Nominal flow	US g.p.m. 0	Max / Min Operating Temperature mech. Seal	°F	120 / -25
4	Nominal head	ft 0	pH-value at t A		7
5	Static head	ft 0	Density at t A	lb/ft ³	62.4
6	Inlet pressure	psi 0	Kin. viscosity at t A	ft ² /s	1.689E-5
7	Environmental temperature	°F 68	Vapor pressure at t A	psi	14.5
8	Available system NPSH	ft 0	Altitude		0

Pump data						
9	Lubrication	Standard, Grease lubrication [Std]				
10	Execution	4 poles motor				
11	Design	Horizontal				
12	Operating speed	1734 rpm	Stages	1		
13	Suction nozzle	DN 65 /	PN 16 /	EN1092-2		
14	Discharge nozzle	DN 50 /	PN 16 /	EN1092-2		
15	Max. casing pressure	psi		Impeller Ø	Max. inch 5 11/16	
16	Max. working pressure	psi	14		designed inch 5 11/16	
17	Impeller type	Radial impeller				Min. inch 4 5/8
18	Head H(Q=0)	ft	32	Flow	Nominal US g.p.m.	
19	Max. shaft power	hp	1.7		Max- US g.p.m.	266.1
20	Pump weight	kg			Min- US g.p.m.	69.8
21	Total weight	lb	101.4	Head	Nominal ft	
					at Qmax ft	13.4
				Shaft power	hp	
				Efficiency	%	
				NPSH 3%	ft	
					at Qmin ft	30.1

Materials					
22		Pump		Shaft Seal	
23	Volute Casing	Cast Iron		Single mechanical seal, without shaft sleeve	
24	Casing Cover	Cast Iron		eMG12 - Ø22mm	BQ7EGG-WA
25	Impeller	Fabricated Stainless Steel		Mechanical seal diameter	7/8 inch
26	Shaft	Stainless steel		1. Rotating ring	Carbon graphite resin impregnated
27	Wear ring	Stainless steel		2. Stationary ring	SiC, silicon carbide, sintered press. less
28	Impeller lock nut and washer	Stainless steel		3. Secondary seal	Ethylene propylene rubber (EPDM)
29	Impeller key	Stainless steel		4. Springs	CrNiMo - Steel
30	Fill and drain plugs	Stainless steel		5. Others	EPDM - WRAS
31				Gaskets of the pump	Ethylene propylene rubber (EPDM)
32					
33					
34					
35					
36					
37					
38					
39					
40					
41					

Motor data					
Electrical and dimensional data refer to IE3 motor					
42	Manufacturer	Lowara			
43	Specific design	IE3 3ph Flange Motor			
44	Type	PLM 90 B14 1,5 kW			
45	Rated power	2.0115 hp	Rated current	6.34 A	
46	Nominal speed	1734 rpm	Rated voltage	220 V	
47	Frame size	90	Service factor	1	
48	Weight	lb 44.1	Degree of protection	IP55	

Remarks					
49					
50					
50					
52					

NSCE50-125/15/P46PCS4

Performance curve

Company name
Contact
Phone number
e-mail address

	Ø mm	Pump capacity Operating range η			Pump head H(Q=0) η		Shaft power P2 P2(Q=0) η			Frequency Hz	
		Min. US g.p.m.	Max. US g.p.m.	Max. US g.p.m.	ft	ft	hp	Max. hp	η hp	rpm	
actual	5 11/16	69.8	266	177	32.4	23.9	1.66	1.52		60	1734
Min.	0	/	/	141	20.7	15	/	0.849			0
Max.	5 11/16	/	/	177	32.4	23.9	/	1.52			0

Power datas referred to:

hydr. Performance acceptance acc. To EN ISO 9906 Class Grade 3B

Water, pure [100%] ; 39.2°F; 62.4lb/ft³; 1.69E-5ft²/s

MEI: N.A - according to Ecodesign Directive 2009/125/EC and Regulation (EU) No.547/2012

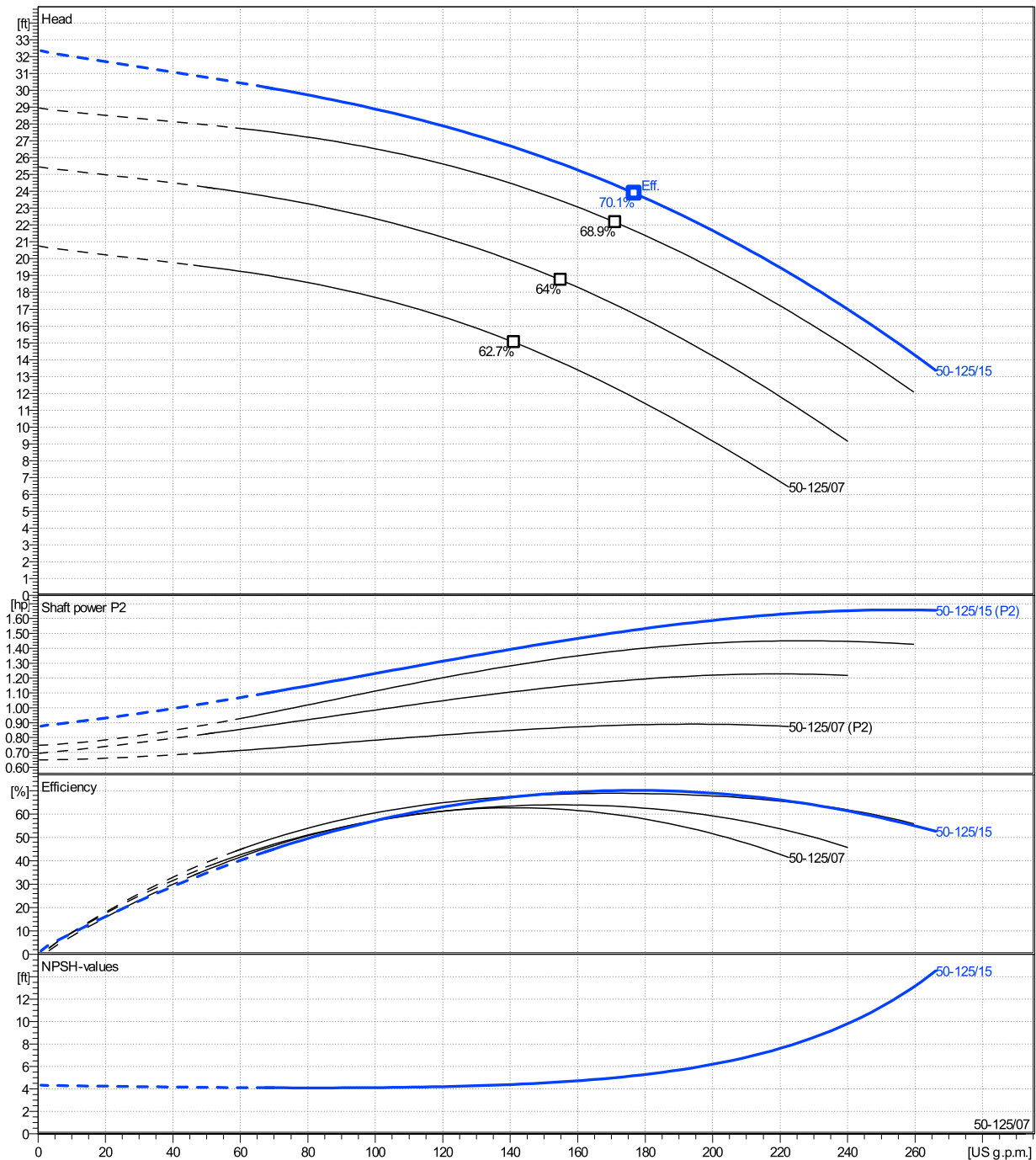

NSCE50-125/15/P46PCS4

Dimensions

Company name
Contact
Phone number
e-mail address

Extended shaft
4 poles motor
PLM 90 B14 1,5 kW

Electrical and dimensional data refer to IE3 motor

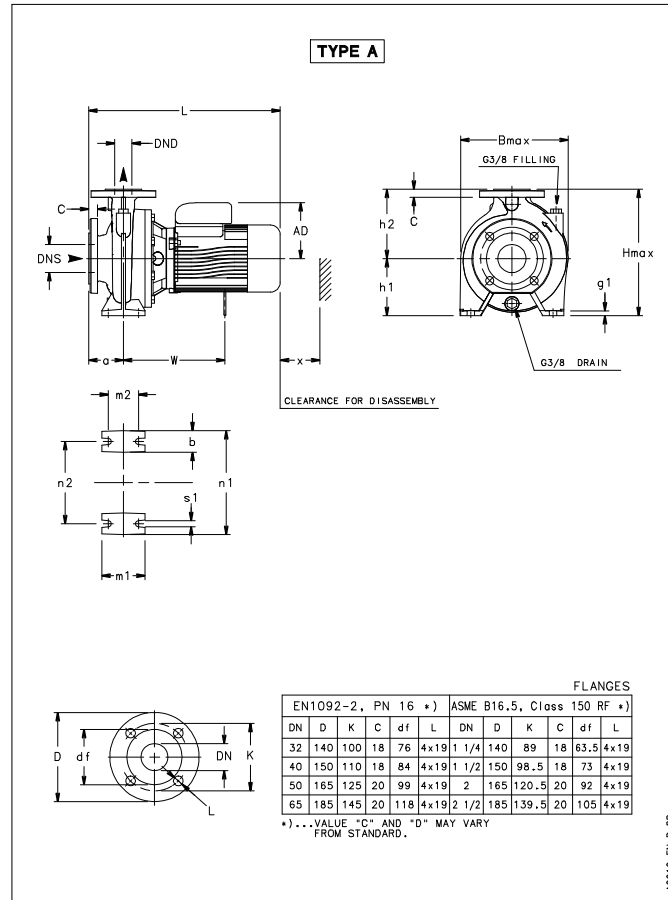

Dimensions [inch]

a	3 ¹⁵ / ₁₆		
AD	5 ¹ / ₄		
B max	10 ¹¹ / ₁₆		
b	1 ¹⁵ / ₁₆		
DND	1 ¹⁵ / ₁₆		
DNS	2 ⁹ / ₁₆		
g1	9 ⁹ / ₁₆		
H max	11 ¹ / ₂		
h1	5 ³ / ₁₆		
h2	6 ⁵ / ₁₆		
L	19 ¹¹ / ₁₆		
m1	3 ¹⁵ / ₁₆		
m2	2 ³ / ₄		
n1	9 ⁹ / ₁₆		
n2	7 ¹ / ₂		
s1	9 ⁹ / ₁₆		
Type	A		
W	9 ³ / ₄		
x	4 ³ / ₁₆		

Weight

Total weight	46 kg
---------------------	--------------

Connections

Suction nozzle		Discharge nozzle	
DN 65		DN 50	
PN 16		PN 16	
EN1092-2		EN1092-2	
C	1 ³ / ₁₆	C	1 ³ / ₁₆
D	7 ⁵ / ₁₆	D	6 ¹ / ₂
df	4 ⁵ / ₈	df	3 ⁷ / ₈
DN	2 ⁹ / ₁₆	DN	1 ¹⁵ / ₁₆
K	5 ¹¹ / ₁₆	K	4 ¹⁵ / ₁₆
L	4 x 19	L	4 x 19

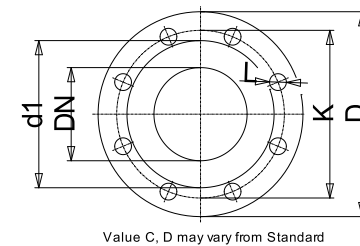

Note:
Weight and Dimensions of selected Hydrovar are NOT considered.
Please refer to additional datasheet.

Dimensions and weight without obligation

Project		Created by		Last update	1/9/2025
Block	NSCE50-125/110/P26PCS4	Created on	1/9/2025		