

NSCF 32-200/30/P25RCS4

Technical data

Company name
Contact
Phone number
e-mail address

Operating data			
1	Pumpe type	Single head pump	Fluid Water, pure
2	No. of pumps	1	Operating temperature t A °C 4
3	Nominal flow	m ³ /h 0	Max / Min Operating Temperature mech. Seal °C 120 / -25
4	Nominal head	m 0	pH-value at t A 7
5	Static head	m 0	Density at t A kg/m ³ 1000
6	Inlet pressure	kPa 0	Kin. viscosity at t A mm ² /s 1.569
7	Environmental temperature	°C 20	Vapor pressure at t A kPa 100
8	Available system NPSH	m 0	Altitude 0

Pump data			
9	Lubrication	Standard, Grease lubrication [Std]	
10	Execution	[F] = 2 poles motor unit with standard cuopling	
11	Design	Horizontal	
12	Operating speed	2900 rpm	Stages 1
13	Suction nozzle	DN 50 / PN 16 / EN1092-2	Impeller Ø
14	Discharge nozzle	DN 32 / PN 16 / EN1092-2	
15	Max. casing pressure	kPa	Flow
16	Max. working pressure	kPa 324.3	
17	Impeller type	Radial impeller	
18	Head H(Q=0)	m 33	Head
19	Max. shaft power	kW 3	
20	Pump weight	kg 38	Shaft power kW
21	Total weight	kg 86.7	
			Efficiency %
			NPSH 3% m

Materials			
22		Pump	Shaft Seal
23	Volute Casing	Cast Iron	Single mechanical seal, without shaft sleeve
24	Casing Cover	Cast Iron	eMG12 - Ø22mm BQ7EGG-WA
25	Impeller	Fabricated Stainless Steel	Mechanical seal diameter 22 mm
26	Shaft	Stainless steel	1. Rotating ring Carbon graphite resin impregnated
27	Wear ring	Stainless steel	2. Stationary ring SiC, silicon carbide, sintered press.less
28	Impeller lock nut and washer	Stainless steel	3. Secondary seal Ethylene propylene rubber (EPDM)
29	Impeller key	Stainless steel	4. Springs CrNiMo - Steel
30	Fill and drain plugs	Stainless steel	5. Others EPDM - WRAS
31			Gaskets of the pump Ethylene propylene rubber (EPDM)
32			
33			
34			
35			
36			
37			
38			
39			
40			
41			

Motor data				Coupling			
42	Manufacturer	Lowara		Manufacturer	Flender		
43	Specific design	IE3 3ph Surface Motor - Premium Efficiency		Series	Standard Coupling - N-EUPEX - Type B		
44	Type	PLM 100 B3 3 kW		Shaft diameter	Pump 24 mm	Motor 28 mm	
45	Rated power	3 kW	Rated current 6.33 A	Frame size	68		
46	Nominal speed	2895 rpm	Rated voltage 400 V	Spacer length	mm 3		
47	Frame size	100	Service factor 1	Weight	kg 0.5		
48	Weight	kg 24.2	Degree of protection IP55	Coupling protection	COUPLGUARD 160x112PNTD		0.24 kg

Base plate		Remarks
49	Name	BASE 3A 900X390 BLU
50	Weight	kg 23.7

NSCF 32-200/30/P25RCS4

Performance curve

Company name
Contact
Phone number
e-mail address

	Ø mm	Pump capacity			Pump head		Shaft power P2			Frequency		Hz	50
		Operating range Min. m³/h	Max. m³/h	η Max. m³/h	H(Q=0) m	η Max. m	P2(Q=0) kW	Max. kW	η Max. kW	Operating speed rpm	Nominal flow m³/h		
actual	158	6.6	25	19	33.1	28.8		2.98	2.6			2900	
Min.	0	/	/	19	33.1	28.8		/	2.6			0	
Max.	205	/	/	28.5	62.4	52.7		/	6.69			0	

Power datas referred to:

hydr. Performance acceptance acc. To EN ISO 9906 Class Grade 3B

Water, pure [100%] ; 4°C; 1000kg/m³; 1.57mm²/s

MEI: >=0,4

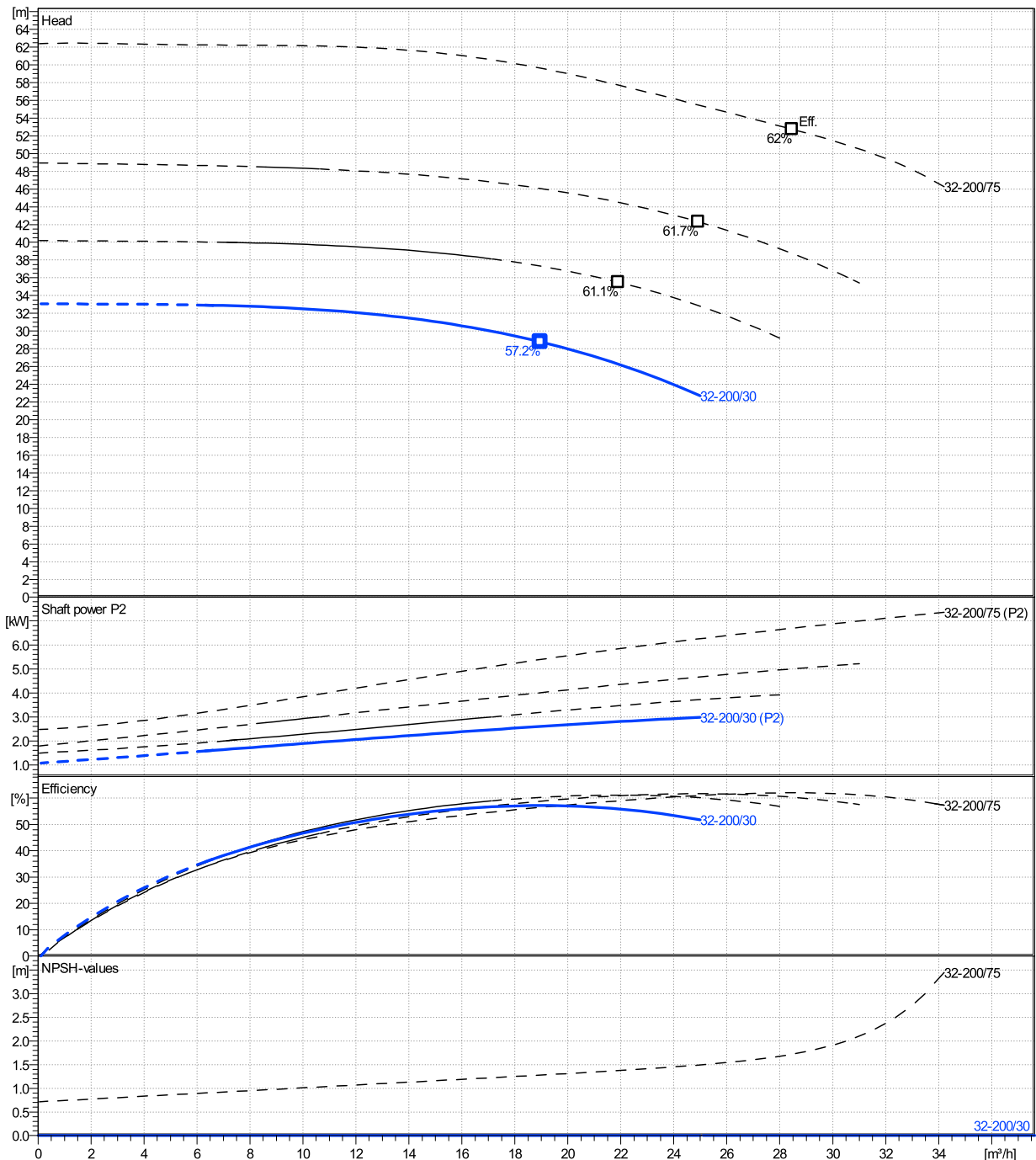

NSCF 32-200/30/P25RCS4

Dimensions

Company name
Contact
Phone number
e-mail address

Frame mounted
[F] = 2 poles motor unit with standard coupling
PLM 100 B3 3 kW

Electrical and dimensional data refer to IE3 motor

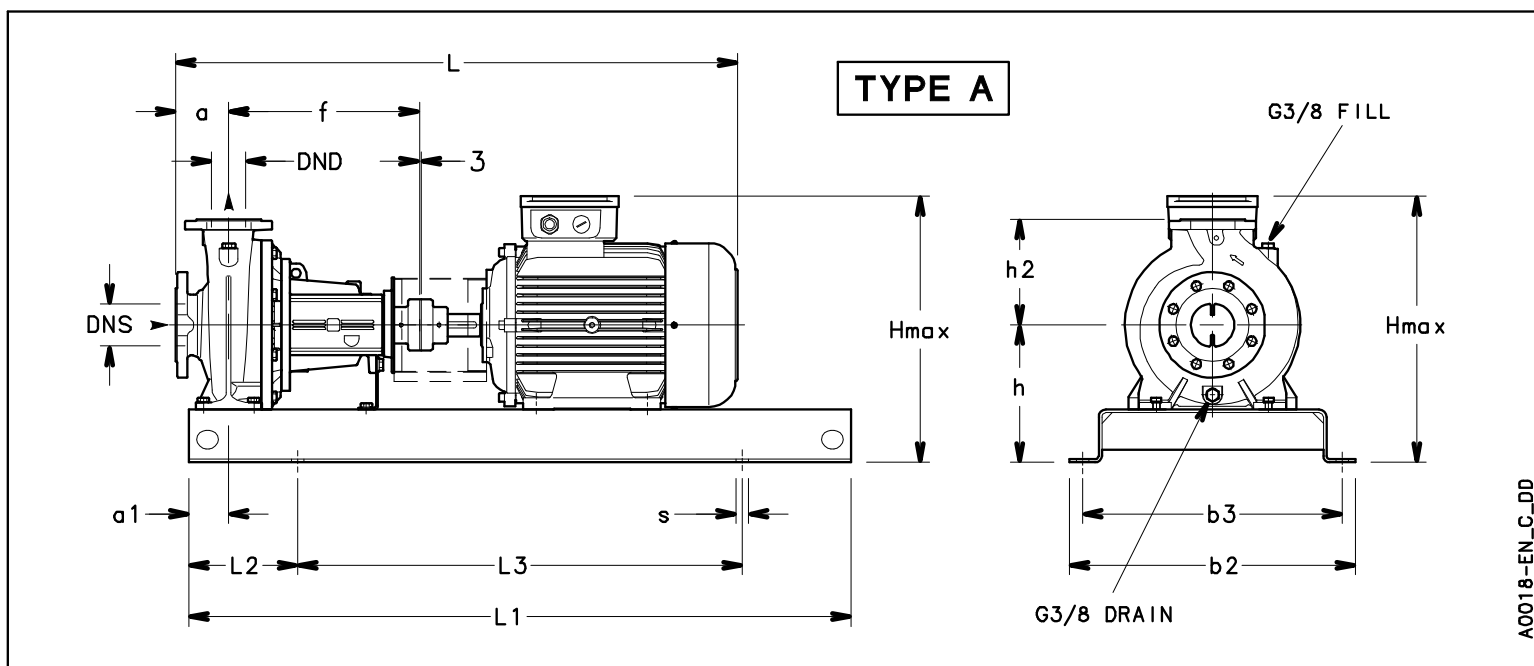

Dimensions		[mm]	
a	80		
a1	60		
AD	154		
b2	390		
b3	350		
DND	32		
DNS	50		
f	360		
Guard	113		
h	260		
h2	180		
Hmax	440		
L	822		
L1	900		
L2	150		
L3	600		
s	4xØ19		
Type	A		
Volumen	0.14106		
x	3		

Weight	
Total weight	86.68 kg

Connections			
Suction nozzle		Discharge nozzle	
DN 50		DN 32	
PN 16		PN 16	
EN1092-2		EN1092-2	
C	20	C	18
D	165	D	140
df	99	df	76
DN	50	DN	32
K	125	K	100
L	4 x 19	L	4 x 19

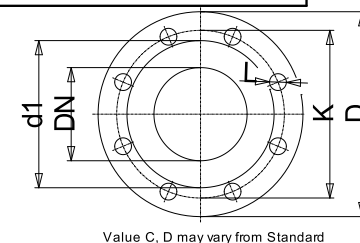

Dimensions and weight without obligation

Project	Xylect-20101351	Created by		Last update	12/15/2024
Block	NSCF 32-200/75/P25VCS4	Created on	12/15/2024		